



Doc. No. NDP 582M-00

MAINTENANCE MANUAL

***G*LOBAL SERIES**

Air-Operated Double Diaphragm Pumps

G50

WARNING



- For your own safety, be sure to read these procedures carefully before performing maintenance on this product. After reading this document, be sure to keep it handy for future reference.

These maintenance manuals cover what you should know about maintenance of the Yamada G50A_ Diaphragm Pumps.

This edition is based on the standards for the May 2024 production run. Remember, the specifications are always subject to change; therefore, some of the information in this edition may not apply to new specifications.

Warnings and Cautions

For safe use of this product, be sure to note the following: In this document, warnings and cautions are indicated by symbols. These symbols are for those who will operate this product and for those who will be nearby, for safe operation and for prevention of personal injury and property damage. The following warning and caution symbols have the meanings described below. Be sure to remember their meanings.



WARNING : If you ignore the warning described and operate the product in an manner, there is danger of serious bodily injury or death.



CAUTION : If you ignore the caution described and operate the product in an improper manner, there is danger of personal injury or property damage.

Furthermore, to indicate the type of danger and damage, the following symbols are also used along with those mentioned above:



This symbol indicates a DON'T, and will be accompanied by an explanation on something you must not do.



This symbol indicates a DO, and will be accompanied by instructions on something you must do in a certain situation.

WARNING



- Before starting maintenance work, cut off the feed air and clean the pump. If air pressure or residue remain in the pump, there is danger of explosion, or possible poisoning resulting in serious injury or death if chemicals adhere to the skin or are accidentally swallowed. (For details on cleaning the pump, refer to Chapter 6 of the Operation Manual.)
*Be fully familiar with the properties of the fluid to be pumped and work in strict accordance with the operating instructions provided by the suppliers of such fluids (such as wearing goggles, gloves, mask or work clothes).



- When replacing parts, be sure to use the recommended genuine parts or Equivalents. Use of other parts may cause a malfunction of the product. (Refer to Parts List the separate sheets.)

CAUTION



- When it is instructed that special tools must be used, be sure to use the specified tools. Otherwise, the pump may be damaged.



- Refer to “10.1 Main specifications” in the Operation Manual. Also, remember that the pump is heavy, and extreme care must be taken when lifting it.

Table of Contents

·Warnings and Cautions	
·Table of Contents	
1.Principles of operation	1
2.Maintenance and Tools	
2.1 Maintenance	1
2.2 General tools	1
2.3 Special tools	1
2.4 Misc.	1
3.Ordering Replacement parts	1
4.Balls and Valve seats	
4.1 Removal	2
4.2 Inspection	3
4.3 Installation	3
5.Diaphragm and Center rod	
5.1 Removal	4
5.2 Inspection	5
5.3 Installation	5
6.Throat bearing and Pilot valve assembly	
6.1 Removal	7
6.2 Inspection	7
6.3 Installation	8
7.C spool valve assembly and Sleeve assembly	
7.1 Removal	8
7.2 Inspection	9
7.3 Installation	9
8.Retightening of Tie rods	10

1. Principles of operation

There are two diaphragms fixed to the center rod, one at each end. When compressed air is supplied to air chamber b (right side, see Fig.1.1), the center rod moves to the right, the material in material chamber B is pushed out, and at the same time material is sucked into material chamber A.

When the center rod is moved full-stroke to the right, the air switch valve is switched, compressed air is sent to air chamber a (left side, see Fig.1.2), and the center rod moves to the left. The material in material chamber A is pushed out, and at the same time material is sucked into material chamber B.

Through repetition of this operation, material is repeatedly taken in and discharged out.

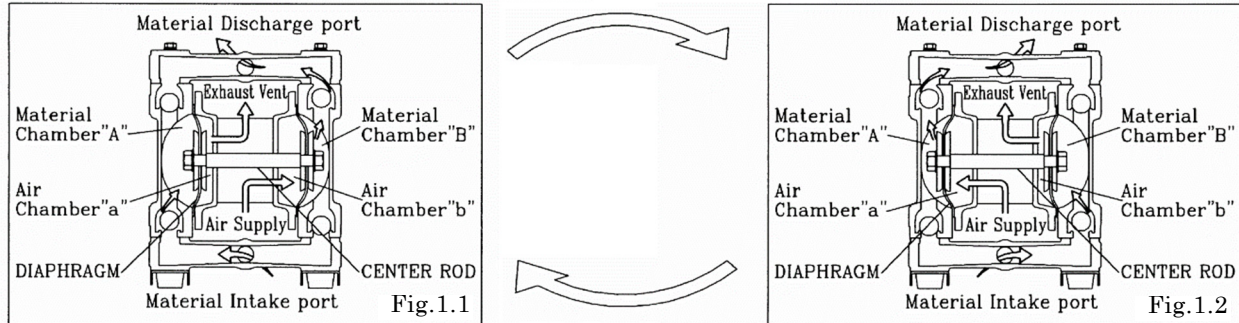

2. Maintenance and Tools

2.1 Maintenance

It is recommended that the pump should be regularly inspected, as this kind of diaphragm pump can be used in many different circumstances such as pressures, temperatures, viscosities, or corrosiveness. It's very useful for your future reference to keep records of the pump conditions for every inspection.

The regular inspection includes the air valve, diaphragms, balls, valve seats, or O-rings.

When it comes to diaphragms, in particular, both of the diaphragms should be replaced at one time, as they tend to be worn out or have some cracks on the surfaces. Please refer to 'usage range' in each section regarding the frequency of the replacement of the other spare parts.

2.2 General tools

- Socket wrenches 17 mm, 24 mm
- Hexagonal box wrench 5 mm
- Small crowbars 2 (excluding AT type)
- Open-end wrenches 17 mm, 24 mm
- Plastic hammer

2.3 Special tools

- Sleeve remover (sold separately)

Purpose: For removing sleeve

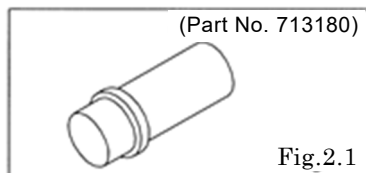

2.4 Misc.

- Assembly oil Turbine oil none addition class 1(equivalent ISO VG32 grade)
- Nuts 2 (M16 X 1.5)
- Thread locker
- Grease Urea grease grade (NLGI) No. 2

3. Ordering Replacement parts

For accurate and speedy shipment of parts, be sure to order the right parts for your model to distributor. Indicate the part numbers, descriptions, and quantities.

4. Balls and Valve seats

4.1 Removal

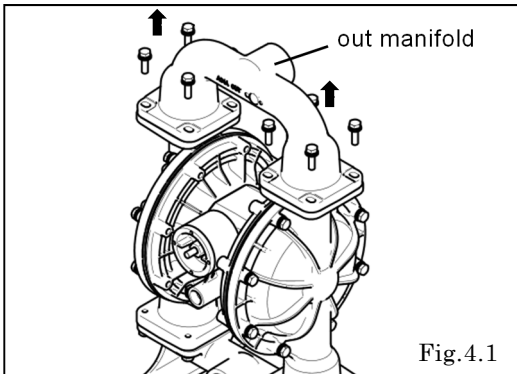

Fig.4.1

- Remove the Silencer and Air valve
- Remove the 8 retainer bolts from the out manifold, and remove the out manifold. <Fig.4.1>

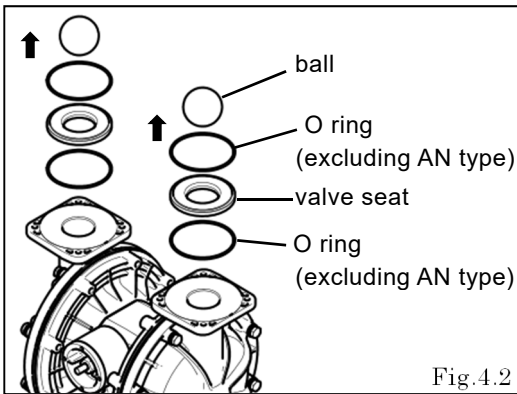

Fig.4.2

- Remove the ball, O ring (excluding AN type) and valve seat. <Fig.4.2>

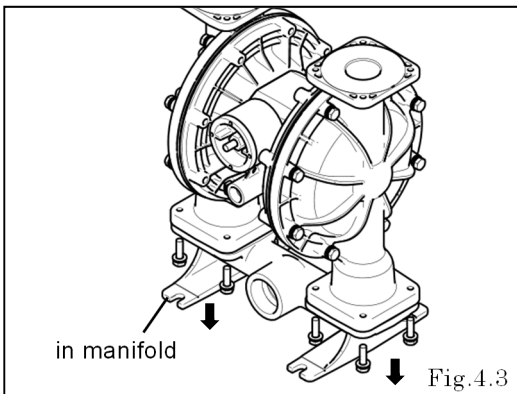

Fig.4.3

- Remove the 8 retainer bolts from the in manifold. <Fig.4.3>

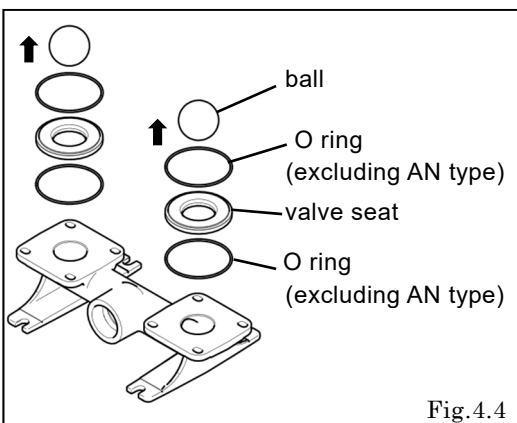
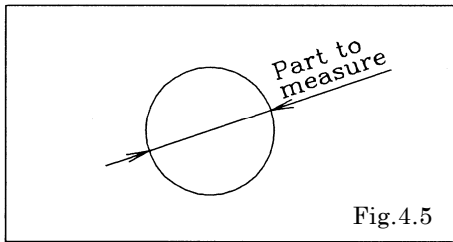

Fig.4.4

- Remove the in manifold, O ring (excluding AN type), valve seat and ball. <Fig.4.4>

4.2 Inspection



- Ball <Fig.4.5>
Measure the outside diameter, and if it is outside the usable range, replace the ball.

Usable range of ball Sø56.7 - Sø64.9 mm
--

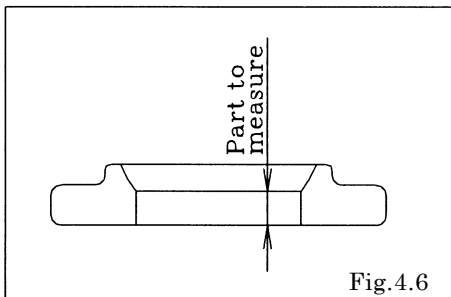

- Valve seat <Fig.4.6>
Measure the dimension shown at left, and if it is outside the usable range, replace the seat.

Usable range of valve seat	
AN	5.0 - 9.5 mm
AT, AH, AS	1.7 - 6.5 mm

AN	5.0 - 9.5 mm
AT, AH, AS	1.7 - 6.5 mm

- O ring (other than PTFE)
If O ring is worn out or cracked, replace it.

4.3 Installation

For installation, see [Exploded View] on the separate sheet and install in the reverse order of disassembly.

Tightening torque for manifold retainer bolts 20 N·m

<NOTE>

- Make sure there is no dust on the seal surface and the seal is not damaged.
- Replace the PTFE O ring regardless of its condition.

5. Diaphragm and Center rod

5.1 Removal

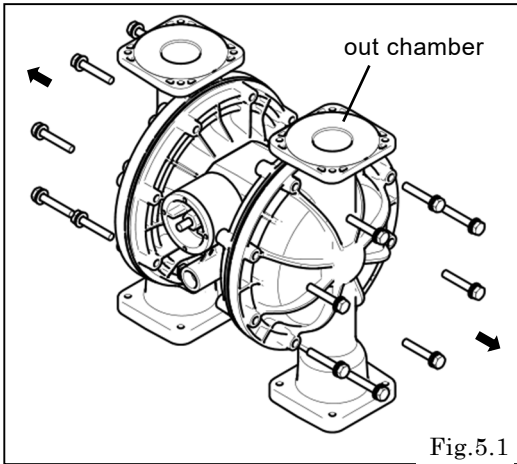

- Remove the balls and valve seats etc. (see “4.1 Removal)
- Remove the 16 retainer bolts from the out chamber, and remove the out chamber. <Fig.5.1>

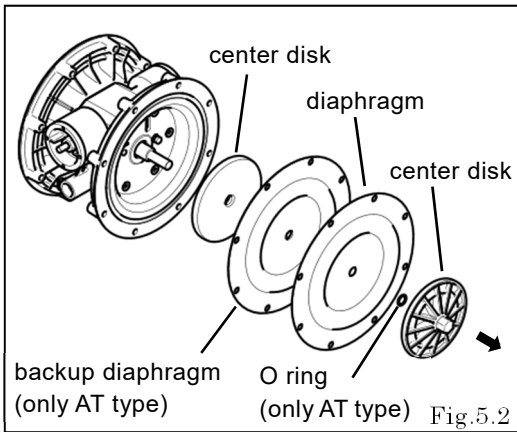

- Remove the center disk (outside) from one side. <Fig.5.2>
- After the center disk (outside) has been removed, remove the O ring (only AT type), diaphragm, backup diaphragm (only AT type) and center disk (inside). <Fig.5.2>

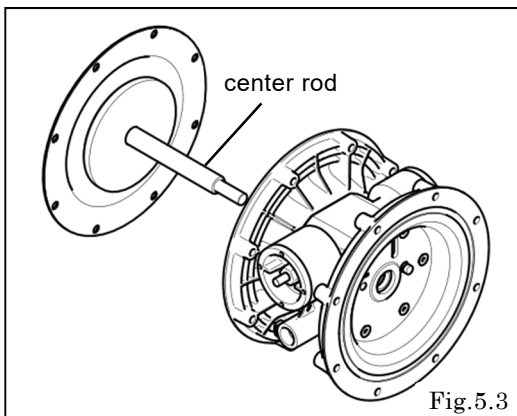

- Remove the center disk, center rod, O ring (only AT type), diaphragm and backup diaphragm (only AT type) from the opposite side of the main body. <Fig.5.3>

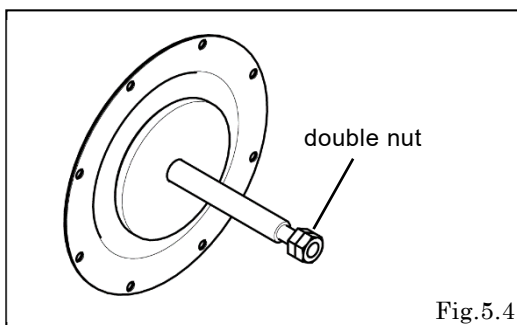

- Fix a double nut to one end of the center rod and take the center disk (outside), O ring (only AT type), diaphragm, backup diaphragm (only AT type) and center disk (inside) off the opposite end. <Fig.5.4>

<NOTE>

- Be careful not to scratch or score the center rod.

5.2 Inspection

▪ Diaphragm

If the diaphragm is worn out or damaged, both of the diaphragms should be replaced at one time.

Please replace it together with the backup diaphragm (only AT type).

Frequency of inspecting the diaphragms
(Transferring water at room temperature)

NBR, TPEE, TPO	7,000,000 cycle
PTFE	2,000,000 cycle

*The standard in our facility is 'Air supply pressure 0.5 MPa with no discharge pressure.'

*It's recommended to conduct an inspection, if 3 months have passed since you start using the pump, or if the number of cycles reaches the above.

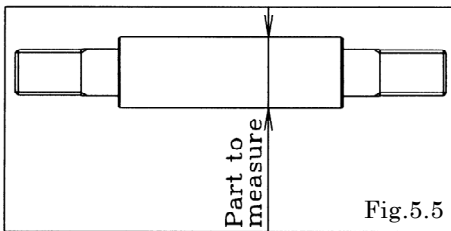

Fig.5.5

▪ Center rod <Fig.5.5>

Measure the diameter, and if it is outside the usable range, replace the rod.

Usable range of center rod

ø24.93 - ø25.00 mm

5.3 Installation

■ AN, AH, AS types

For installation, see [Exploded View] on the separate sheet and install in the reverse order of disassembly.

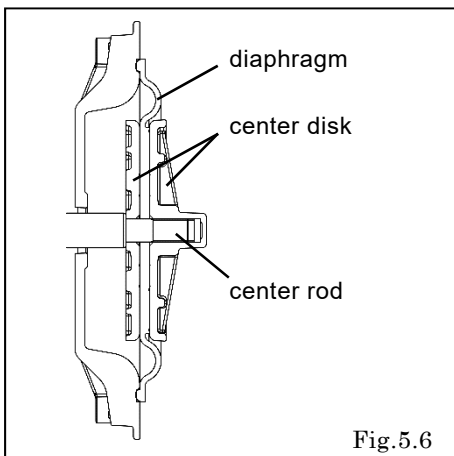

Fig.5.6

- Apply assembly grease to the center rod, and insert it into the main body.
- Keep the convex side to the outside for diaphragm.
- Apply proper Thread locker to the thread of center disk.

Tightening torque for center rod

60 N·m

- Draw the center disk to one side. <Fig.5.6>
- And install the out chamber. Tighten the bolts temporarily.
- Grip the inside center disk using crowbars and draw it to the opposite side, then turn the diaphragm over. <Fig.5.7, 5.8>
- And install the out chamber. Tighten the bolts temporarily.
- After installation of the out chambers on both sides, place the pump on a flat surface and stand the pump upright for further assembly.

Tightening torque for out chamber

30 N·m

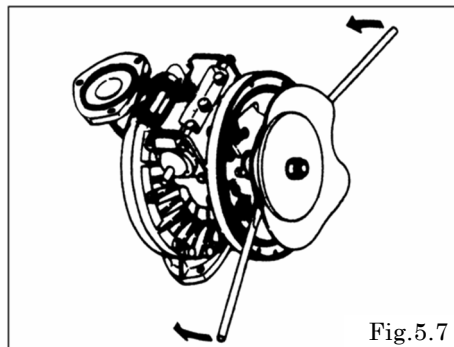

Fig.5.7

<NOTE>

- Make sure there is no dust on the seal surface in order to prevent seal damaged.
- Be careful not to damage the R portion of the air chamber using a crowbar, etc.
- Tighten the bolts gradually in a diagonal sequence with even torque. <Fig.5.9>

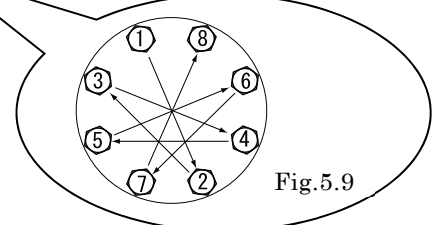

Fig.5.9

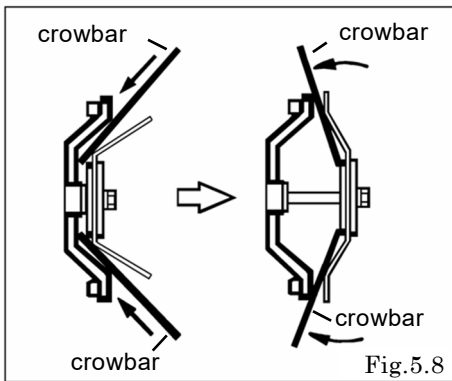

Fig.5.8

■ AT type

For installation, see [Exploded View] on the separate sheet and install in the reverse order of disassembly.

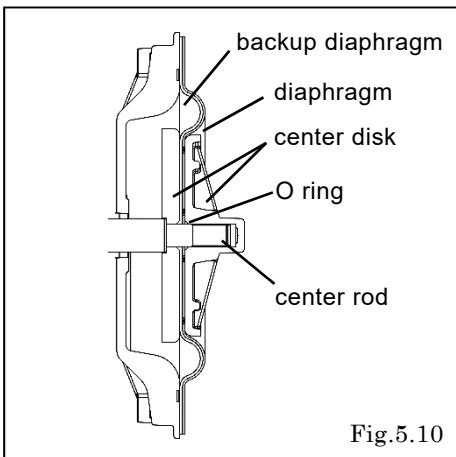

Fig.5.10

- Apply assembly grease to the center rod, and insert it into the main body.
- Keep the convex side to the outside for diaphragm and backup diaphragm.
- Put the O ring to outside of the diaphragm. <Fig.5.10>
- Apply proper Thread locker to the thread of center disk.

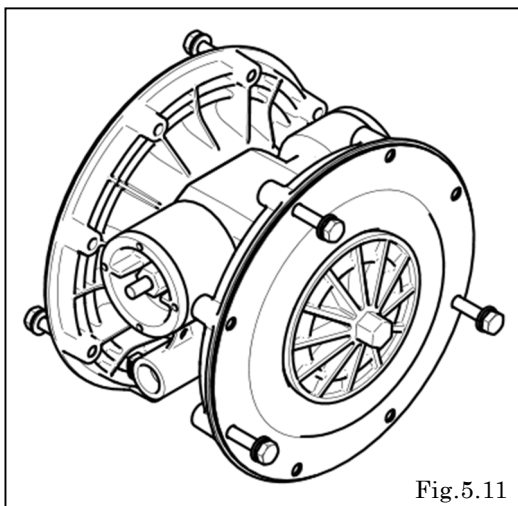

Fig.5.11

- Put three bolts through the holes on the diaphragm, and temporarily fasten them to the air-chamber. <Fig.5.11>

<NOTE>

Those three bolts are to fix the positions of the holes on the air-chamber and the diaphragm. So tentatively tighten those bolts by rotating them by hand three to four times.

Tightening torque for center rod

60 N·m

- Remove the bolts used for positioning.
- Tighten the out chamber temporarily at first. After installation of the out chambers on both sides, place the pump on a flat surface and stand the pump upright for further assembly.

Tightening torque for out chamber

40 N·m

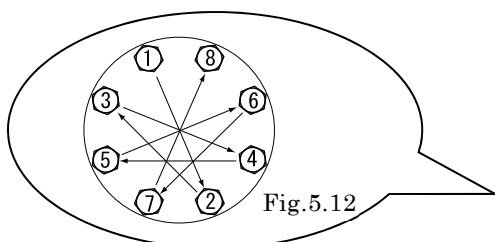

Fig.5.12

<NOTE>

- Make sure there is no dust on the seal surface in order to prevent seal damaged.
- Replace the PTFE O ring by new one.
- Tighten the bolts gradually in a diagonal sequence with even torque. <Fig.5.12>

6. Throat bearing and Pilot valve assembly

6.1 Removal

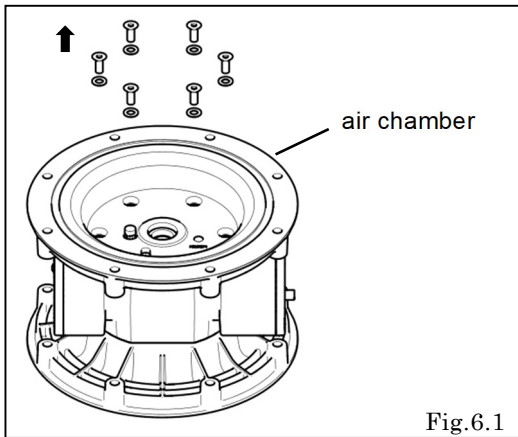

- Remove the diaphragm and center rod (see “5.1 Removal”).
- Remove the 12 retainer bolts from the air chamber, and remove the air chamber. <Fig.6.1>

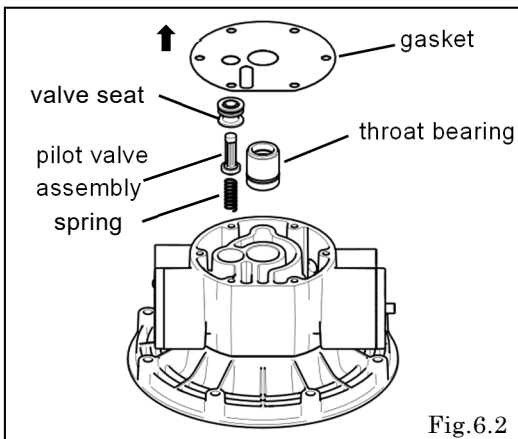

- Remove the gasket. <Fig.6.2>
- Draw out the pilot valve assembly, valve seat and spring. <Fig.6.2>
- Draw out the throat bearing. <Fig.6.2>

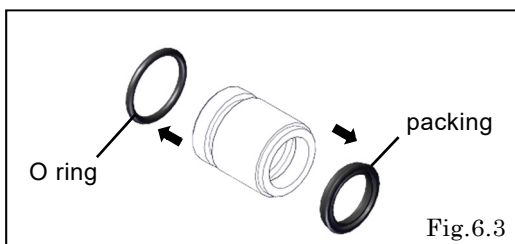

- Remove the packing and O ring from the throat bearing. <Fig.6.3>

6.2 Inspection

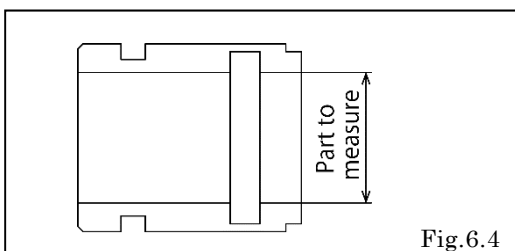

- Throat bearing <Fig.6.4>
Measure the inside diameter, and if it is outside the usable range, replace the throat bearing

Usable range of throat bearing

$\varnothing 25.04 - \varnothing 25.15 \text{ mm}$

- O ring
If the O ring is worn out or cracked, replace it.
- Packing
If the Packing is worn out or cracked, replace it.
- Pilot valve assembly
If the pilot valve assembly is worn out or cracked, replace it.

6.3 Installation

For installation, see [Exploded View] on the separate sheet and install in the reverse order of disassembly.

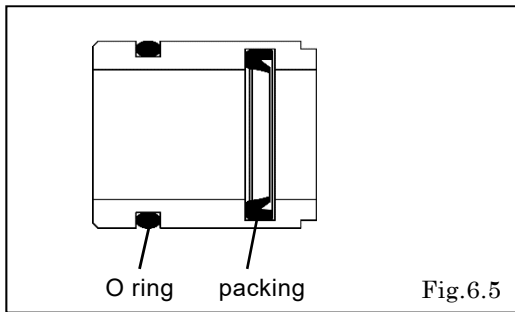

Tightening torque for air chamber retainer bolts

20 N·m

<NOTE>

- Make sure there is no dust on the seal surface and the seal is not damaged.
- Apply grease to packing.

7. C spool valve assembly and Sleeve assembly

7.1 Removal

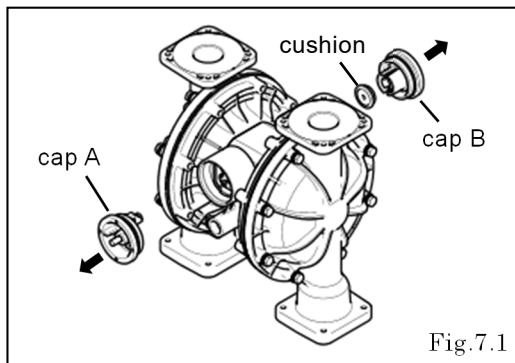

- Remove the cap A and cap B. <Fig.7.1>
- Draw out the cushion. <Fig.7.1>

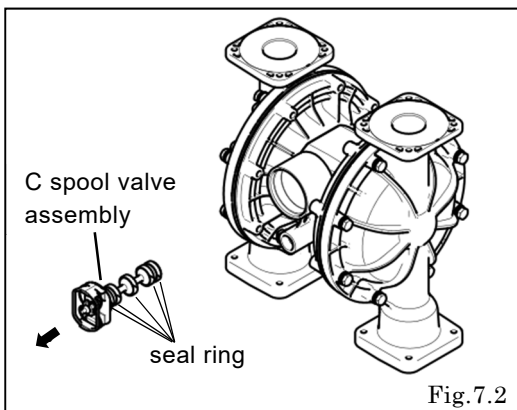

- Draw out the C spool valve assembly, and remove the seal ring from the C spool valve assembly. <Fig.7.2>

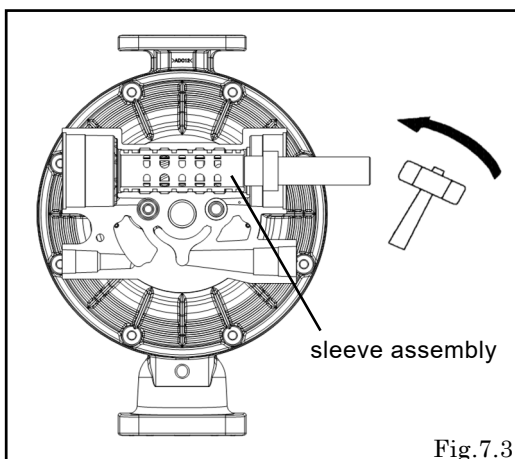

- Remove the sleeve assembly using the sleeve remover (special tool: Part number 713180). <Fig.7.3>

7.2 Inspection

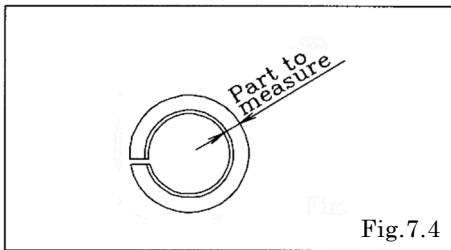

- C Spool valve assembly
Seal ring <Fig.7.4>
Measure the inside thick diameter, and if it is outside the usable range, replace the C spool valve assembly.
If the seal ring is worn out or cracked, replace C spool valve assembly.

Usable range of Seal ring

3.77 - 3.85 mm

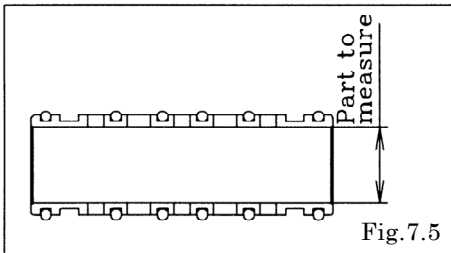

- Sleeve assembly <Fig.7.5>
Measure the inside diameter, and if it is outside the usable range, replace the c spool valve assembly.

Usable range of sleeve assembly

ø33.15 - ø33.35 mm

- O ring
If the O ring is worn out or cracked, replace it.

<NOTE>

- C spool valve assembly must be replaced as a complete set.
Unable to replace individual component.

7.3 Installation

For installation, see [Exploded View] on the separate sheet and install in the reverse order of disassembly.

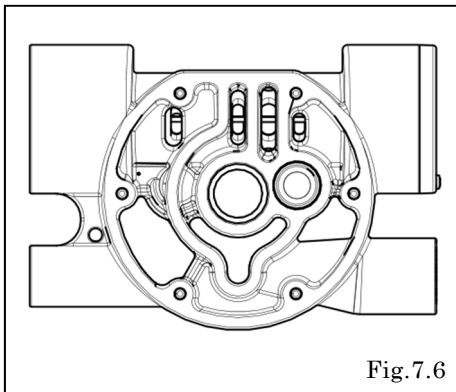

- Apply grease or oil to the O ring of the cap B (Side cap without reset button) and install the cap B into the body.

Tightening torque for installation cap B

20 N·m

- Install the sleeve assembly using the sleeve remover (special tool: Part No. 713180). At this point, apply assembly oil around the sleeve assembly and O ring.
- Install the sleeve assembly until it contacts cap B. <Fig.7.6>
- Apply grease or oil to the O ring of the cap A.
- Insert the convex part of the C spool valve assembly into the concave part of the Cap A firmly, and deeply install the cap A into the body. <Fig.7.7>

Tightening torque for installation cap A

20 N·m

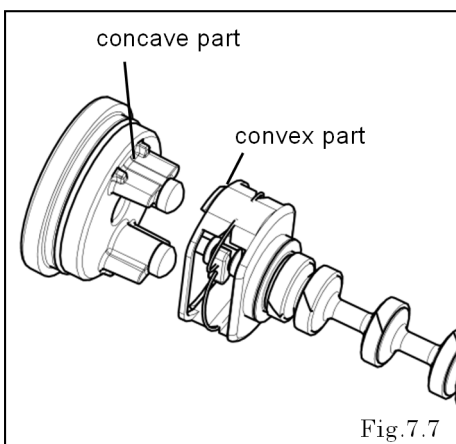

<NOTE>

- Make sure there is no dust on the seal surface and it is not damaged.

8. Retightening of Tie rods

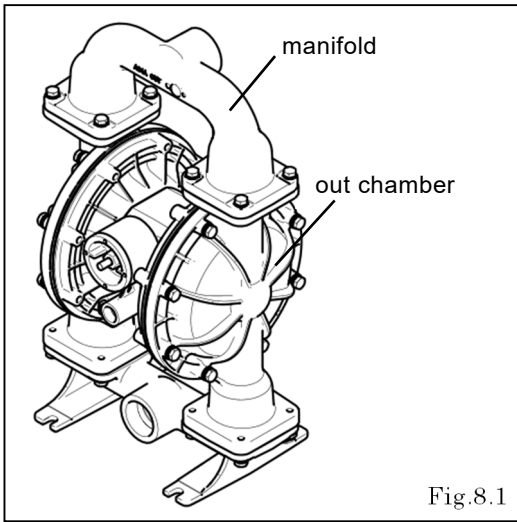

- All bolts should be retorqued:
 - (1) Right before start up.
 - (2) There are any leaks of material on daily inspecting a pump.

<NOTE>

- Retighten the out chamber and then the manifold in this order. <Fig. 8.1>
- Tighten the bolts in the order shown. <Fig. 8.2>

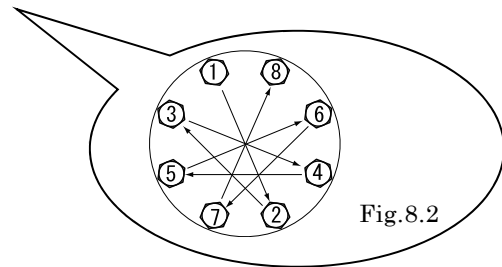

	Retainer bolts for the out chamber	Retainer bolts for the manifold
AN, AS, AH	30 N·m	20 N·m
AT	40 N·m	

YAMADA CORPORATION

INTERNATIONAL DEPARTMENT

1-1-3, Minami-Magome, Ota ku, Tokyo, 143-8504, Japan

PHONE : +81-(0)3-3777-0241

FAX : +81-(0)3-3777-0584

E-mail : intl@yamadacorp.co.jp

Web : www.yamadacorp.co.jp

YAMADA (THAILAND) CO., LTD

41/79 Moo 6, Bangcha-long, Bangplee, Sumutprakarn 10540, Thailand

PHONE : +66-(0)2-130-0990

FAX : +66-(0)2-130-0993

E-mail : sales@yamada-th.com