



# INSTRUCTION

## ELECTRIC GREASE LUBRICATOR (24VDC)

KPL-24 EX ITEM No.880639

KPL-24 FGL ITEM No.881120



### **WARNING**

Prior to operating this pump, be sure to read this operation manual for safety. After reading the manual, please keep it at hand any time for your quick reference.

## EC DECLARATION OF CONFORMITY

Name of company : YAMADA CORPORATION

Address : 1-1-3, Minami-Magome, Ota ku, Tokyo, 143-8504 Japan

declares, in sole responsibility, that the following product

Equipment : GREASE LUBRICATOR

Type : KPL-24 series

Referred to in this declaration conforms with the following standard(s) or directive(s) :

- Directive 2004/108/EC
- Directive 2006/42/EC
- EN-ISO 12100:2010
- EN 809:1998 + A1:2009

YAMADA CORPORATION will keep on file for review the following technical documentation :

- operating instructions as required
- plans
- description of measures designed to ensure conformity
- other technical documentation

Importer / Authorized Representative in EU

Name of company : YAMADA EUROPE B.V.

Atsushi Yamaguchi (Managing Director)

Address : Aquamarijnstraat 50, 7554 NS Hengelo (0), The Netherlands

Place and date issued : Sagamihara Factory / December 16, 2019

Name and signature as well as position of undersigned :

Kotaro Yamada (Director, Sagamihara Factory)



*K. Yamada*

## - Preface

Thank you for purchasing a Yamada Pump. This machine is a portable lubricator for dispensing grease for machines and vehicles. This lubricator cannot be used for oil lubrication. The applicable grease is limited to a type of NLGI No.2 or less in the normal operating conditions. If the lubricator is used in an extremely cold or low-temperature environment, the discharge volume will decrease. Do NOT use silicon grease.

## - For Safe Operation

This manual describes the items that are important for the user to operate this product safely, correctly, and efficiently. Before operating this product, read this manual thoroughly, in particular, "Warnings and Cautions" at the beginning of this manual.

## - Warnings and Cautions

For safe use of this product, be sure to note the following: In this document, warnings and cautions are indicated by symbols. These symbols are for those who will operate this product and for those who will be nearby, for safe operation and for prevention of personal injury and property damage. The following warning and caution symbols have the meanings described below. Be sure to remember their meanings.



**WARNING** : This indicates the existence of potential hazard which, if not avoided, will result in death or serious injury.



**CAUTION** : This indicates the existence of potential hazard which, if not avoided, may result in bodily injury or in physical damage.

Furthermore, to indicate the type of danger and damage, the following symbols are also used along with those mentioned above:



This symbol indicates a DON'T, and will be accompanied by an explanation on something you must not do.





















This symbol indicates a DO, and will be accompanied by instructions on something you must do in a certain situation.











## - Precautions on Use

The following warnings and cautions are very important. Be sure to observe them.

### **WARNING**

-  - Not waterproof. Not drip-proof. Avoid wet locations and keep your hand dry. There might be the electric shock.
-  - Not explosion-proof. Avoid a flammable atmosphere. There might be an explosion, the fire.
-  - Keep your face and hands away from the outlet when handling the check valve. Air-containing material may suddenly come out. There is a possibility of losing eyesight and injuring the hand.
-  - Do not aim exhalation part of this product at any person. Residual pressure may be left inside the gun even when the pump is not in operation. There is a possibility of losing eyesight if it strikes eyes.
-  - Gasoline is a high volatile fuel. Do not use it to clean the pump in any case, otherwise ignition or explosion may be caused.
-  - Modification of this product may lead to death, bodily injury, or a failure. Do not modify it in any case because it involves a risk.
-  - The operator and maintenance engineer should read the operation manual thoroughly before operating this product and performing maintenance in respect of this product.
-  - Always wear proper safety equipments (facemask, ear plugs, protective gloves and safety shoes, etc.) when installing, operating, and disassembling this product.
-  - Do not use or leave this product in a slope or any unstable locations. The damage only accident and the facilities pollution by the fall of this product might occur if this product is used in an unstable place. Such a secondary disaster becomes a responsibility on the user side.
-  - Execute the daily checkup.
-  - Use this product according to the product specification.
-  - Be careful not to drop this product when lifting it up to replace a pail. Catching a falling product may cause hand injury by its edge.
-  - Turn off the power supply to stop pump operation when removing the pump from a pail. Being caught in a shovel, the lowest part of the pump, can cause hand injury and malfunction of the pump.
-  - Discontinue it when you feel a hazard or abnormality during the work. And correspond according to the "4.1 Troubleshooting and Corrective Measures".
-  - Stop pump operation immediately when a drum becomes empty. Running the pump dry will cause excessive vibration, resulting in reduction of pump life and damage to other equipment.
-  - Be very careful not to drop the grease gun. It may become damaged, resulting in leakage and malfunction.
-  - Avoid unnecessary adjustment of relief valve. There is a threat that machinery is damaged.
-  - Before maintenance operation, be sure to stop power supply from being supplied to the pump, and release the internal pressure (material) of the pump. There is danger such as spouting of the material when the maintenance work is done with power supplied.
-  - Do not discharge material directly onto the ground. Dispose of harmful materials according to the requirements specified in SDS or local regulations. Also, dispose of this product according to the local regulations after removing residual material from inside this product. (Please contact industrial waste disposal service.)

 **CAUTION**

-  - Keep hands and fingers away from this product during operation to avoid injury from moving parts.
-  - Do not use a power supply except 24VDC for this product. There might be malfunction of this product, the electric shock and the fire.
-  - Use this product for the material suitable for the specification. Parts may be corroded and material leak from the damaged parts can lead to environmental pollution. Also, follow handling notes (SDS) of the manufacturer about the handling of the material used.
-  - Take protective measures against rainwater and dust. It is likely to lead to the pollution of the material.
-  - Be careful about your hands when mounting/dismounting the cabinet or installing a pail. The edges of this product and pail may cause hand injury. Also, be careful about your posture when moving this product or lifting it to avoid back injury.
-  - Material remaining inside or on the surface of the pump may spill out by inserting or removing the pump into/from a pail. Be very careful not to get your clothing dirty.
-  - Do not touch the surfaces of the pump and the hose when pumping high-temperature material. Risk of burns exists.
-  - Be careful when handling the grease gun. Avoid finger injury from being caught between the lever and gun. The finger might be injured.
-  - Stop the power supply source after the end of work when not using this pump for a long time such as nighntimes and holidays. Also, open the valve of the exhalation port and liberate pressure in the pump and the hose. There is a possibility of polluting facilities because of the damage of the hose and the leakage of the valve. Such a secondary disaster becomes a responsibility on the user side.
-  - Use a fuse of 10A for this product.

# Table of Contents

- Preface	
- For Safe Operation	
- Warnings and Cautions	
- Precautions on Use	
<b>1. Names and Materials of Parts</b>	
1.1 Names and Materials of Parts .....	1
1.2 Contents of Package .....	1
<b>2. Preparations before Operation</b> .....	2
<b>3. How to Operate the Machine</b> .....	3
<b>4. Maintenance and Inspection</b>	
4.1 Troubleshooting and Corrective Measures .....	4
4.2 Maintenance and Inspection .....	4
<b>5. Disassembly and Assembly</b> .....	5
<b>6. Parts Disassembly Drawing and Parts List</b>	
6.1 880639 KPL-24EX, 881120 KPL-24FGL .....	7
6.2 852164 Grease gun .....	7
6.3 851835 Pump assembly .....	8
<b>7. Specification</b> .....	10
<b>8. Limited Warranty</b> .....	11



## 2. Preparations before Operation

### [Assembling the unit] (Fig. 1)

- 1) Insert the pump assembly in the center hole from the top side of the lid.
- 2) Fix the pump assembly and the lid with 3 pan-head screws from the underside of the lid.
- 3) Connect the high-pressure hose for grease (sold separately) to the valve kit at the pump discharge port and connect a high-pressure grease gun to the other end of the hose.

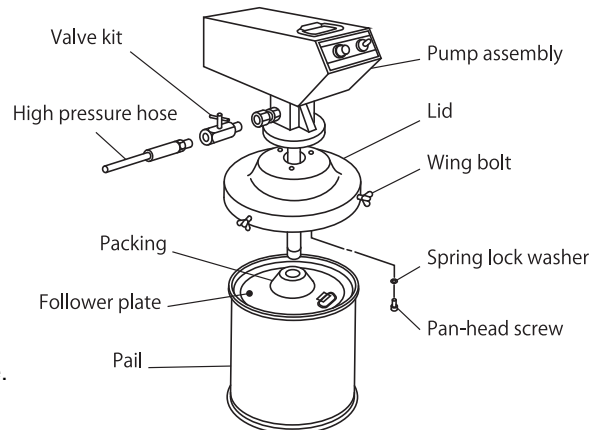

Fig.1

### [Setting the pump] (Fig. 1)

- 4) Remove the lid of a new pail and set the attached follower plate. Place the follower plate on the grease horizontally and push it down by rocking it to left and right by hand until the grease comes out from the packing in the middle of the plate.

### <NOTE>

When using the follower plate for the first time, pack grease beforehand in the under-side concave portion of the plate. (Fig. 2)

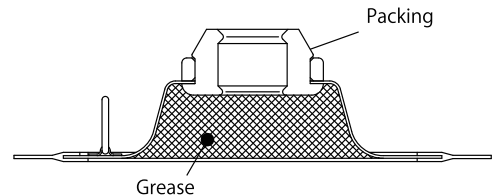

Fig.2

- 5) Insert the pump in the center hole of the follower plate and set the lid on the pail. Fix it securely by screwing 3 wing bolts equally.

### <NOTE>

Take extreme care not to allow sand and dust to adhere on the suction tube and follower plate of the pump assembly. Use caution to prevent damaging the packing in the follower plate when installing the pump through it.

### [Connecting to power supply]

- 6) Place the unit on a flat and stable place.
- 7) Connect the attached cabtyre assembly (2.5 m) to the power supply.

### <NOTE>

This equipment is not polarity sensitive.

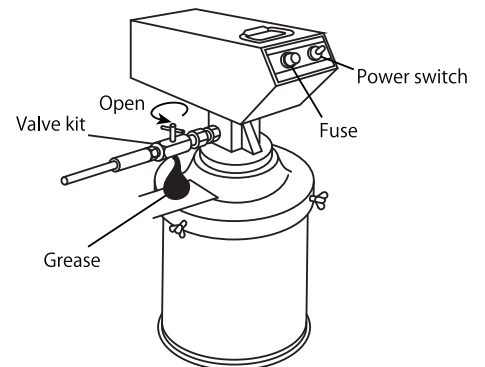
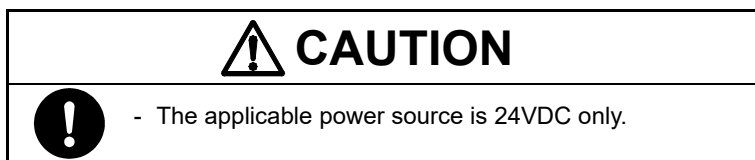



Fig.3



### [Bleeding air for grease] (Fig. 3)

- 8) The pump starts running by turning the switch ON. When priming the pump always bleed entrapped air at the bleed valve first. First open the bleed valve kit and operate the pump until grease is discharged from a small hole under the check valve. After grease is discharged continuously, close the valve kit. At this time, spread paper so that grease may not come into contact with the hand, and dispose of the discharged grease.
- 9) Discharge the air-mixed grease completely from the high-pressure grease gun and the hose by pulling the gun lever.



### 3. How to Operate the Machine

 <b>WARNING</b>	
	- Do not operate the gun lever with the discharge port facing to another person during machine operation. A direct hit against the human body may result in an accident such as skin damage.

 <b>CAUTION</b>	
	- Regarding a secondary accident such as hose damage that may be caused without shutting off of the power supplied to the hose or installation contamination due to a leak from the valve or gun after completion of the work or at night, the responsibility rests with the user side.
	- When the pump causes a malfunction or operation stop, do not disassemble the pump thoughtlessly and disassemble only necessary portions referring to “4.1 Troubleshooting and Corrective Measures” and judging the situation properly.

**<NOTE>**

The electric grease pump runs continuously even if the grease gun is closed. When internal pressure goes up to 28 MPa /4000 psi, the grease is relieved by a pressure relief valve automatically. The pressure relief valve operates to prevent the motor from overloading and returns the grease to pail through the outer tube.

- 1) Wipe the grease nipple to be used for greasing completely. After that, push the hydro chuck of the high-pressure grease gun against the grease nipple vertically. (Fig. 4)
- 2) Pull the lever of the high-pressure grease gun to supply grease. The pump is automatically operated to supply grease. When grease is normally injected, old grease will be squeezed out from the groove or clearance bear the nipple.
- 3) After completion of grease supply, release the gun lever. The grease supply will be stopped.
- 4) Remove the hydro chuck of the grease gun. Since pressure is applied to the hydro chuck, the head of the nipple may be broken if it is suddenly pulled. Incline the hydro chuck to bleed the internal fluid pressure and loosen the claw bite, and the chuck can be easily removed. (Fig. 5)
- 5) After completion of greasing work or when the pump is not used for a long time, be sure to shut off the pump and bleed the internal fluid pressure to the grease gun, and hose by operating the gun lever.
- 6) If the pump is run dry due to the absence of grease or cavitations, push down on the follower plate and open the bleed valve to expel the air/grease mixture. This should return the pump back to normal operation. If the grease is used up, replace with a new pail.

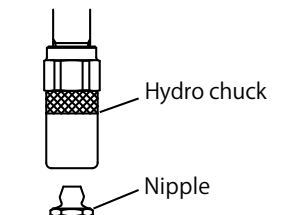



**Fig.4**



**Fig.5**

**[Replacing the pail]**

 <b>CAUTION</b>	
	- When replacing the pail, be sure to shut off the power supply for safety and pull the gun lever to bleed the internal pressure of the pump and hose beforehand.

- 7) Unscrew the 3 wing bolts of the lid, and remove the pump unit from used pail and take out the follower plate.
- 8) Remove the lid of a new pail and place the follower plate on the grease horizontally and push the follower plate by rocking it until grease comes out from the center hole.
- 9) Insert the pump in the packing in the middle of the follower plate and set the lid on the pail. Screw the 3 wing bolts equally and tighten lid securely.

## 4. Maintenance and Inspection

### 4.1 Troubleshooting and Corrective Measures

Symptom	Contents of inspection	Corrective measure
- The pump fails to start.	<ul style="list-style-type: none"> <li>- Check if the power cable is cut.</li> <li>- Check if the fuse is blown.</li> <li>- Uninstall the lower pump and operate only by the motor.</li> </ul> <p style="text-align: center;">↓</p> <p>(Separate the lower pump and operate the pump with only the motor.)</p> <ul style="list-style-type: none"> <li>→ If the pump is operating, the lower pump is defective.</li> <li>→ If the pump is not operating, the motor is defective.</li> </ul>	<ul style="list-style-type: none"> <li>- Change to the new cable.</li> <li>- Change to new fuse (10A).</li> </ul> <ul style="list-style-type: none"> <li>- Repair service for the lower pump.</li> <li>- Repair service.</li> </ul>
- The pump is operating but does not supply grease.	<ul style="list-style-type: none"> <li>- Check if the delivery hose and grease gun is clogged.</li> <li>- Check the grease is empty.</li> <li>- Check for air pockets between the follower plate and grease.</li> <li>- Uninstall the lower pump and operate only by the motor.</li> </ul>	<ul style="list-style-type: none"> <li>- Remove the cause of clogging.</li> <li>- Replace to the new pail.</li> <li>- Install the follower plate horizontally and push down till the grease comes out from the packing. Then operate the pump again.</li> <li>- Check the lower pump.</li> </ul>
- The pump is operated but the pressure and flow rate are insufficient.	<ul style="list-style-type: none"> <li>- Check for loose connections of valve kit, hose and gun.</li> <li>- Check if the relief valve is loose.</li> <li>- Check if the valve seat at lower pump is worn out.</li> </ul>	<ul style="list-style-type: none"> <li>- Tighten the connections</li> <li>- Adjust the relief valve at proper position.</li> <li>- Change to new valve seat.</li> </ul>
- Grease leaks from the motor.	<ul style="list-style-type: none"> <li>- Check if the seal packing between motor and pump is worn out.</li> </ul>	<ul style="list-style-type: none"> <li>- Change to new seal packing.</li> </ul>
- The pump makes noise.	<ul style="list-style-type: none"> <li>- Check for valve obstructions.</li> </ul>	<ul style="list-style-type: none"> <li>- Remove the foreign substance.</li> </ul>

### 4.2 Maintenance and Inspection

The hose is a consumable part. Check it periodically, replace it if any blemish or leakage is found, and rebuild annually.

## 5. Disassembly and Assembly



### CAUTION

 - Do not clean this pump with gasoline.

 - Do not use strong acidity/alkaline solvent which corrode aluminum, steel, and etc.

 - Before disassembling and inspecting the machine, be sure to shut off the power supply and open the outlet valve to release the internal pressure of the pump.

### [Disassembling the lower pump]

When trouble such as unstable operation or the pump stops, do not disassemble the pump immediately. Should pump fail refer to "4.1 Troubleshooting and Corrective Measures" and confirm the situation of the pump unit. Do not disassemble the part that is not concerned with the trouble.

- 1) Shut off the power supply. Bleed the internal pressure of the pump and hose and high-pressure hose from the pump.
- 2) Unscrew 3 wing bolts that fix the lid and the pail, and dismantle the unit from pail.
- 3) Unscrew 3 pan-head screws that fix the pump and the lid, and disassemble the lid from the pump.
- 4) Secure the pump assembly in a vise. (Fig.6)
- 5) Unscrew valve adapter. Pull the outer tube from the pump with the outer tube extended as far as possible. A roll pin will be exposed. Drive out the roll pin with a punch. Then unscrew the union and separate the pump from the motor. (Fig. 6)
- 6) Pull out the out tube. If only the valve adapter pulled out, unscrew the nut and remove the plate. Then pull out the out tube and screw the suction tube with pipe wrench (set on notched part of the suction tube). Pull out the pin and unscrew the union, and the lower pump can be separated from the motor. (Fig. 6, 7)
- 7) Secure the lower pump cylinder in a vise. Then unscrew the valve adapter with a spanner wrench. Then remove the valve seat, foot valve and valve ring. (Fig. 8)
- 8) Set a pipe wrench on notched part of the suction tube and unscrew it. The piston valve assembly can be removed. (Fig. 9)
- 9) Flatten the bending part of the washer that fixes the union and the piston. Separate the union and the piston with a spanner, and then remove the ball and the spring. (Fig. 9)
- 10) Wash each part and inspect for damage and wear. Replace parts as necessary. If the metal seal parts are damaged or worn out, grease will leak and discharge pressure cannot be increased, and consequently discharge volume will be decreased. In this case the piston and the cylinder must be replaced. (Fig.10)

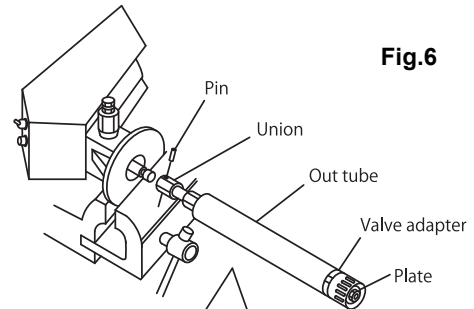

Fig.6

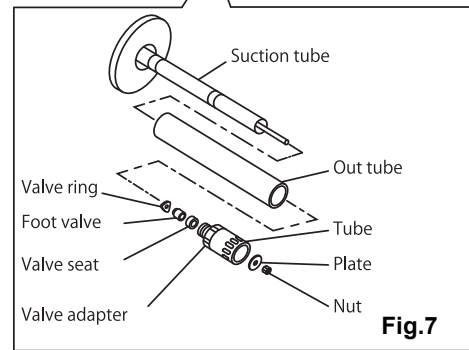

Fig.7

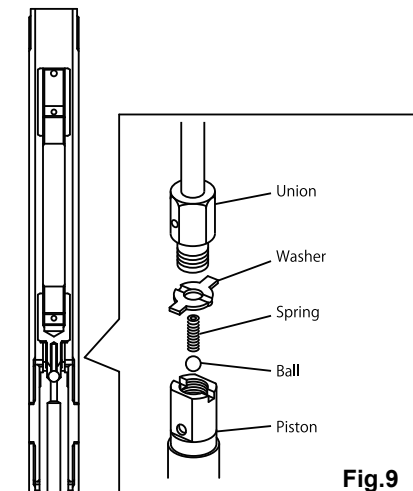

Fig.9

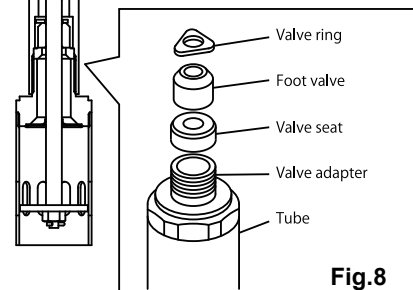

Fig.8

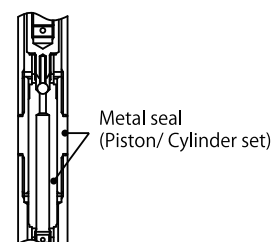
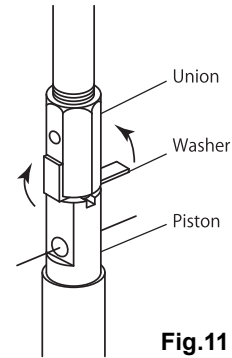

Fig.10

**[Assembling the lower pump]**

**- Assembling the intake valve**

- 11) Insert the ball into the piston. Insert the spring into the union. Put the washer between the piston and the union, and then connect each other. At this time keep both edges of the washer at a right-angled position against the side of the hexagon part of the union. Then screw the union with a spanner and tighten to the piston firmly. Bend both edges of the washer to the direction to the union. This prevents the unit from loosening. (Fig.11)



**Fig.11**

**- Assembling the foot valve**

- 12) Insert the intake valve assembly to the suction tube. (Fig.12)
- 13) Insert the valve ring, the foot valve and the valve seat in order. Be sure the direction of each part is correct. (Fig.12)
- 14) Thread the valve adapter to the tube. Install the plate with the nut. (Fig.12)
- 15) Insert the suction tube from opposite side of valve adapter. Pull out the union from the suction tube and screw it to the connecting rod of the motor side. Adjust the position of pin-hole of both the suction and the union, and insert the pin. (Fig.6)
- 16) Screw the suction tube into the crankcase of the upper motor by hands. Then tighten it firmly with a wrench.

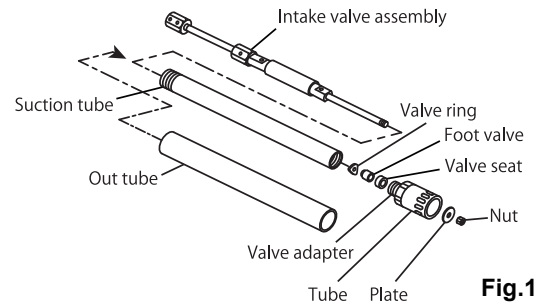

**Fig.12**

**[Disassembling the upper motor] (Fig.13)**

- 17) Remove the packing retainer with tweezers.
- 18) Remove the packing and the back up ring with tweezers.
- 19) When replacing with new parts put a little grease on the packing and install with correct direction.

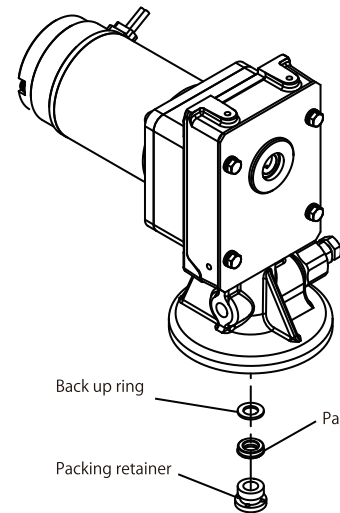

**Fig.13**

**[Adjusting the relief valve] (Fig.14)**

The relief valve is factory preset to 28 MPa / 4000 psi adjusting is not necessary. If the relief valve is loosened for some reason, adjust with the procedure shown below.

<b>CAUTION</b>
- Please guard the following procedure.

- 1) Remove the delivery hose and the valve kit, and then install high-pressure ball valve with pressure gauge (Max. 50 MPa / 7250 psi) instead of the hose and the valve kit.
- 2) Operate the pump. After checking grease discharge, shut off the high-pressure ball valve. Adjust the relief valve to make the pressure gauge points to 28 MPa / 4000 psi. Tighten the nut on the relief valve firmly.

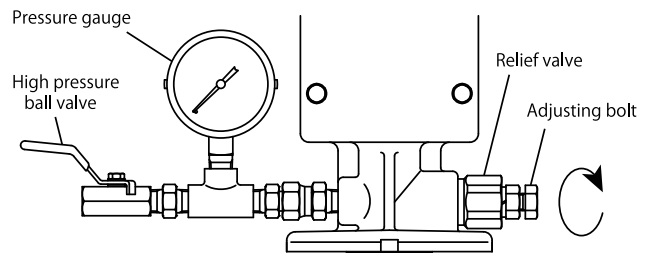

**Fig.14**

## 6. Parts Disassembly Drawing and Parts List

### 6.1 880639 KPL-24 EX, 881120 KPL-24FGL

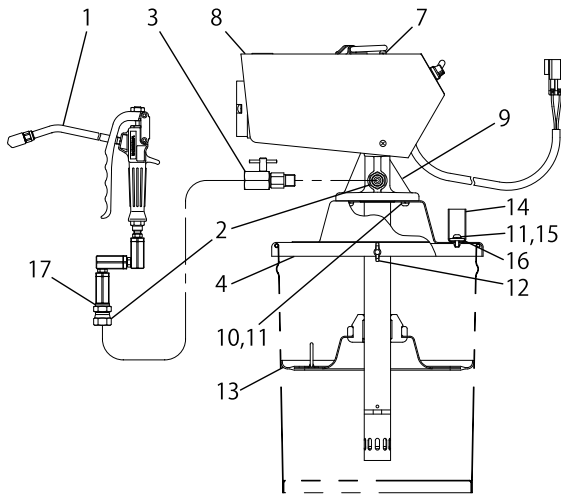

No.	PART No.		DESCRIPTION	Q'TY
	880639	881120		
1	852164		Grease gun assembly	1
2	685940		Union adapter	2
		685940		1
3	802584	←	Valve kit	1
4	710915	←	Lid	1
7	683347	←	Screw with washer	4
8	802649	←	Cover assembly	1
9	851835	←	Grease pump assembly	1
10	602296	←	Machine screw	3
11	631418		Spring lock washer	4
		631418		3
12	610623	←	Wing bolt	3
13	803085		Follower plate assembly	1
14	707937		Gun holder	1
15	602298		Machine screw	1
16	707880		Plain washer	1
17	701930		Plain washer	2

### 6.2 852164 Grease gun

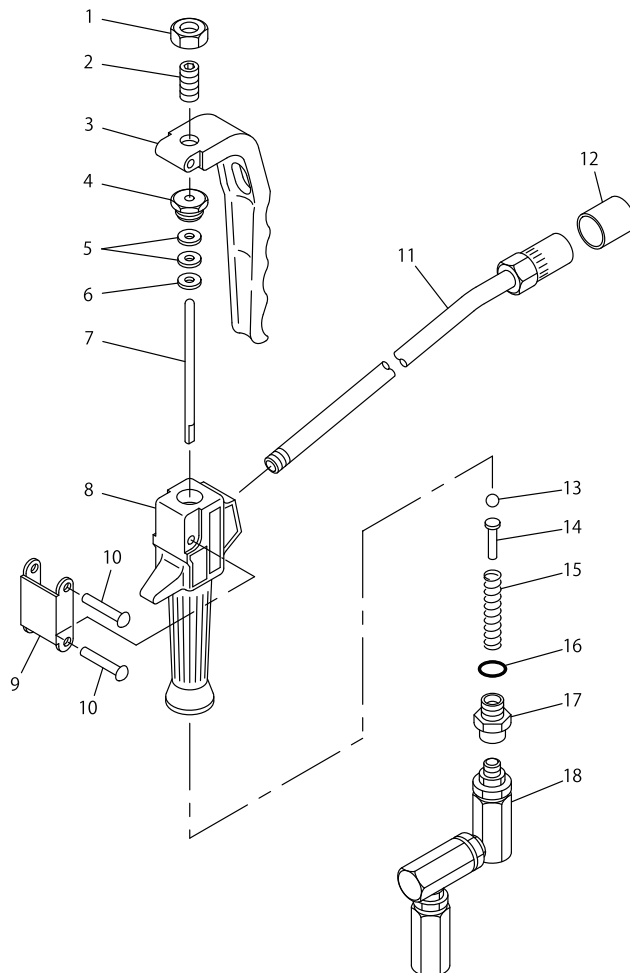

No.	PART No.	DESCRIPTION	Q'TY
1	627641	Nut	1
2	711750	Bolt	1
3	711354	Lever	1
4	711444	Retaining nut	1
5	772160	Packing	2
6	713638	Washer	1
7	711357	Rod	1
8	711352	Body	1
9	711351	Link	1
10	683201	Rivet	2
11	804912	Nozzle	1
12	685728	Cap	1
13	630314	Ball	1
14	711445	Spring retainer	1
15	711446	Spring	1
16	640011	O ring	1
17	710971	Union	1
18	802910	Swivel joint assembly	1

### 6.3 851835 Pump assembly

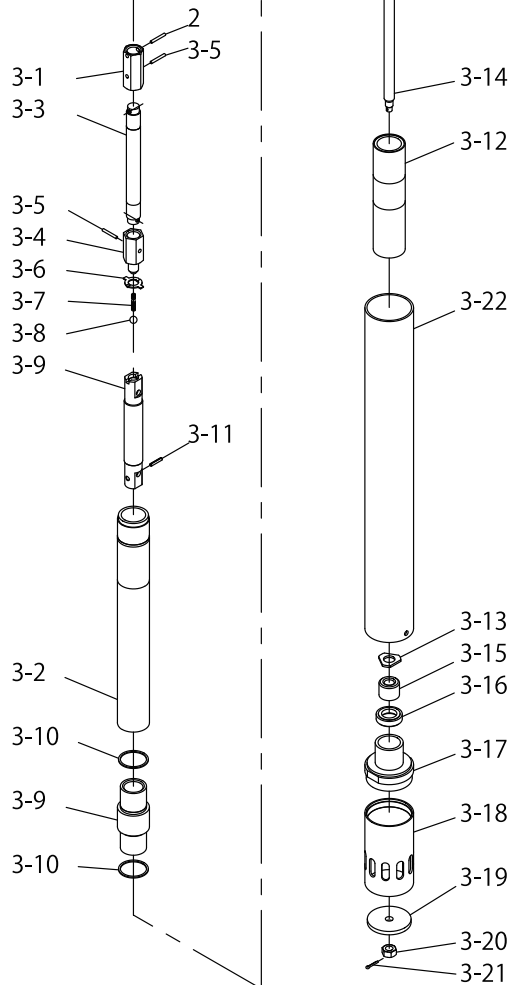
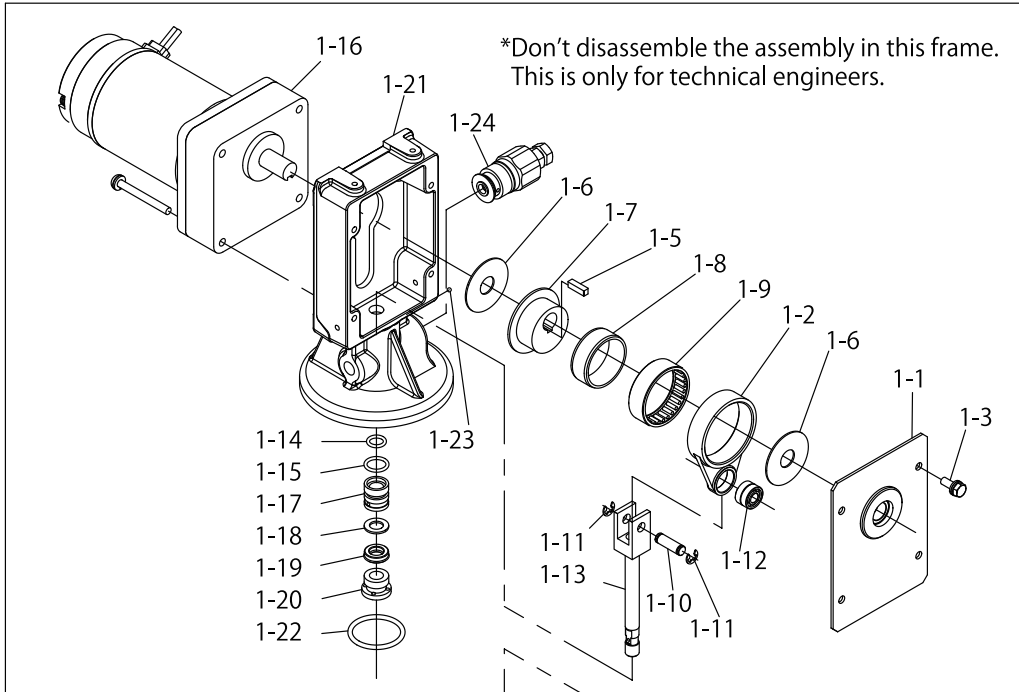

No.	PART No.	DESCRIPTION	Q'TY
1	802589	Pump assembly	-
1-1	832933	Cover assembly	1
1-2	713240	Link	1
1-3	682262	Bolt	4
1-5	716029	Key	1
1-6	713230	Stopper	2
1-7	713231	Cam	1
1-8	682994	Inner ring	1
1-9	682995	Needle bearing	1
1-10	710808	Pin	1
1-11	630779	Stop ring	2
1-12	684347	Ball bearing	2
1-13	833039	Connecting rod	1
1-14	640009	O ring	1
1-15	640014	O ring	1
1-16	686381	Motor assembly	1
1-17	710813	Bushing	1
1-18	771405	Back up ring	1
1-19	771418	Packing	1
1-20	710896	Packing retainer	1
1-21	715988	Crank case	1
1-22	640037	O ring	1
1-23	630310	Ball	1
1-24	802587	Relief valve assembly	1
2	702971	Pin	1
3	802588	Lower pump assembly	-
3-1	706091	Union	1
3-2	709642	Suction tube	1
3-3	709643	Rod	1
3-4	702975	Union	1
3-5	702971	Pin	2
3-6	702974	Washer	1
3-7	702976	Spring	1
3-8	630313	Ball	1
3-9	801051	Cylinder assembly	1
3-10	702977	Washer	2
3-11	632754	Spring pin	1
3-12	706072	Foot tube	1
3-13	702980	Valve ring	1
3-14	706399	Plunger rod	1
3-15	771404	Foot valve	1
3-16	702982	Valve seat	1
3-17	830407	Valve adapter assembly	1
3-18	712043	Tube	1
3-19	702984	Plate	1
3-20	627010	Nut	1
3-21	632019	Split pin	1
3-22	710815	Out tube	1

## 7. Specification

### ■ Specification

TYPE		KPL-24EX	KPL-24FGL
MODEL No.		880639	881120
RATED VOLTAGE		24VDC	
MOTOR RATED	OUTPUT	90 W	
	RATED CURRENT	6.3 A	
MAXIMUM DISCHARGE PRESSURE		<CONSECUTIVE RATING> 24 MPa	<30 MINUTES RATING> 28 MPa
MAXIMUM DISCHARGE VOLUME		<CONSECUTIVE RATING> 135 g / min	<30 MINUTES RATING> 110 g / min
MAXIMUM OPERATING NOISE	A-WEIGHTED SOUND PRESSURE LEVEL *1	60 dB	
AMB. TEMP. RANGE	ENV. TEMPERATURE	-10 ~ 40 °C	
	MATERIAL TEMP.	0 ~ 80 °C	
WEIGHT		12.0 kg	10.5 kg
ACCESSORIES		802704 Cabtyre assembly (2.5 m with connector)	
		852164 Grease gun	※Grease gun, Union adapter, and Follower plate are optional extras.
		685940 Union adapter	
OPTION		803085 Follower plate	
		852042 Hose reel (SHR-3C15K)	
		852077 Hose reel (SHR-3C10K)	
		695303 High-pressure delivery hose (3/8" x 10 m)	
		802817 Power cord for extension (5 m)	
		851003 Carry (S-20)	

\*1 Measurement method of A-weighted sound pressure level is based on ISO 1996.

### ■ Performance Curve

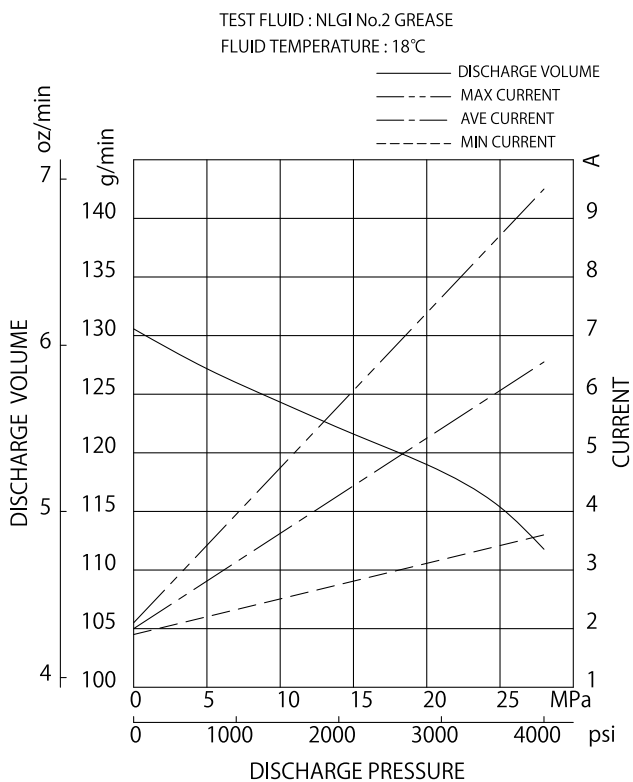

### ■ Dimensions

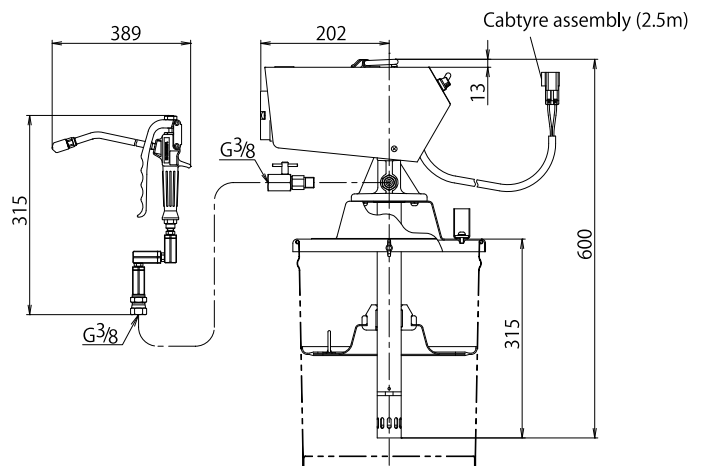

## 8. Limited Warranty

If an abnormality occurs during normal operation in accordance with the operating instructions and other operating cautions within the warranty period (12 months after date of purchase) that can be attributed to a manufacturing defect, the defective parts of this product will be serviced or the product will be replaced free of charge. However, this warranty will not cover compensation for incidental damage or any malfunction listed below.

### 1. Warranty period

This warranty will be valid for a period of 12 months after the date of purchase.

### 2. Warranty

If, during the warranty period, any of the material of the genuine parts of this product or the workmanship of this product is found defective, and is so verified by our company, the servicing cost will be fully born by our company.

### 3. Exclusion

Even during the warranty period, this warranty does not cover the following.

- 1) Malfunction arising from use of parts other than manufacturer-specified genuine parts
- 2) Malfunction arising from misuse or operating errors, or lack of storage or maintenance care
- 3) Malfunction arising from use with a fluid that may cause corrosion, inflation or dissolution of the component parts of the product
- 4) Irregularity arising from repair made by other than by our firm, our regional office, dealer or authorized service personnel
- 5) Malfunction arising from modification of the product by other than authorized service personnel
- 6) Wear and tear of parts that must be regularly replaced in the course of normal operation, such as packings, O-rings and hose.
- 7) Malfunction and/or damage due to use with incorrect voltage.
- 8) Malfunction and/or damage due to transportation, moving or drop page of the product after purchase
- 9) Malfunction and/or damage due to fire, earthquake, flood or other force majeure
- 10) Malfunction arising from use of compressed air that contains impurities or excessive moisture, or use of gases or fluids other than the specified compressed air
- 11) Malfunction arising from use of excessively abrasive material or of inadequate grease.

Furthermore, this warranty does not cover the rubber parts, or other parts used in this product and its accessories, which are subject to wear in normal operation.

- hoses
- packings
- cords

### 4. Parts

Parts for this product will be kept available for 5 years after discontinuation of production. Once 5 years have elapsed after close of production, availability of parts for this product cannot be guaranteed.





## **YAMADA EUROPE B.V.**

Aquamarijnstraat 50,7554 NS Hengelo (O),The Netherlands

PHONE : +31-(0)74-242-2032

FAX : +31-(0)74-242-1055

E-mail : sales@yamada.nl

Web : www.yamada-europe.com

Manufactured by

## **YAMADA CORPORATION**

**International Sales Department**

1-1-3, Minami-Magome,Ota ku, Tokyo, 143-8504, Japan

PHONE : +81-(0)3-3777-0241

FAX : +81-(0)3-3777-0584

E-mail : intl@yamadacorp.co.jp

Web : www.yamadacorp.co.jp