

Original Instructions **CE**

Doc. No. OSA 011U-10



OPERATION MANUAL

GREASE LUBRICATOR

KPL- 55 EX ITEM No.880873

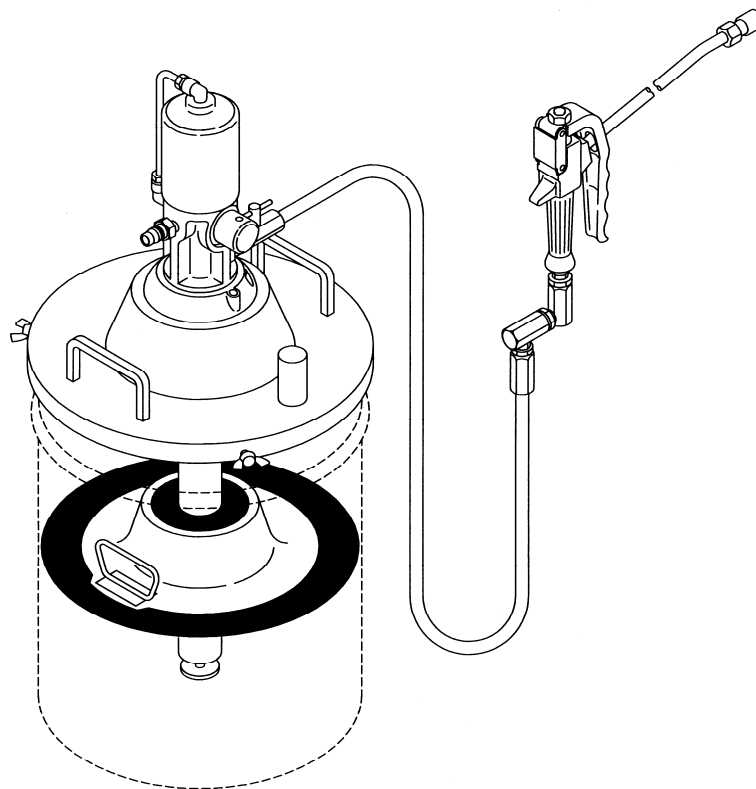

WARNING

Prior to operating this pump, be sure to read this operation manual for safety. After reading the manual, please keep it at hand any time for your quick reference.

YAMADA CORPORATION

EC DECLARATION OF CONFORMITY

Name of company : YAMADA CORPORATION

Address : 1-1-3, Minami-Magome, Ota ku, Tokyo, 143-8504 Japan

declares, in sole responsibility, that the following product

Equipment : GREASE LUBRICATOR

Type : KPL-55EX series

Referred to in this declaration conforms with the following standard(s) or directive(s) :

- Directive 2006/42/EC
- EN-ISO 12100:2010
- EN 809:1998 + A1:2009

YAMADA CORPORATION will keep on file for review the following technical documentation :

- operating instructions as required
- plans
- description of measures designed to ensure conformity
- other technical documentation

Importer / Distributor in EU

Name of company : YAMADA EUROPE B.V.

Atsushi Yamaguchi (Managing Director)

Address : Aquamarijnstraat 50, 7554 NS Hengelo (0), The Netherlands

Place and date issued : Sagamihara Factory / December 16, 2019

Name and signature as well as position of undersigned :

Kotaro Yamada (Director, Sagamihara Factory)

CE

K. Yamada

- Preface

Thank you very much for purchasing Yamada Pump. This machine is a portable type lubricator that is indispensable for grease lubrication for machines and vehicles. This lubricator cannot be used for oil lubrication. The applicable grease is limited to a type of NLGI No.2 or less in the normal operating conditions. If the lubricator is used in an extremely cold or low-temperature environment, the discharge volume will be remarkably lowered. Silicone grease is not applicable.

- For Safe Operation

This document describes the items that are important for the user to operate this product safely, correctly, and efficiently. Before operating this product, read this manual thoroughly, in particular, "Warnings and Cautions" at the beginning of this manual, with a good understanding of its contents. Keep this manual carefully in an easy-to-access place so that the user may refer to it whenever necessary.

- Warnings and Cautions

To use this product safely, be sure to observe the contents of the following description. In this manual, warnings and cautions are indicated by using symbols. These symbols are intended to prevent death or serious injury that may be caused to the operator or those who are around the product and damage that may be caused to the articles that are around the product, as well as to use the product safely and correctly. Each symbol is indicated and has a meaning as shown below. Read the description with a good understanding of its contents.



WARNING : This indicates the existence of potential hazard which, if not avoided, will result in death or serious injury.



CAUTION : This indicates the existence of potential hazard which, if not avoided, may result in bodily injury or in physical damage.

To indicate the contents of danger and damage, the following symbols are used together with the above indications.



This symbol indicates an act that is prohibited (prohibition). The concrete contents of prohibition are indicated by the side of the indication.





















This symbol indicates the contents that must be observed. The concrete contents of observance are indicated by the side of the indication.

- Precautions on Use

The following warnings and cautions are very important. Be sure to observe them.

WARNING

-  - Keep your face away from the exhaust and discharge ports. Material may suddenly come out. There is a possibility of losing eyesight if it strikes eyes.
-  - Keep your face and hands away from the outlet when handling the check valve. Air-containing material may suddenly come out. There is a possibility of losing eyesight and injuring the hand.
-  - Do not aim exhalation part of this product at any person. Residual pressure may be left inside the gun even when the pump is not in operation. There is a possibility of losing eyesight if it strikes eyes.
-  - Gasoline is a high volatile fuel. Do not use it to clean the pump in any case, otherwise ignition or explosion may be caused.
-  - Modification of this pump may lead to death, bodily injury, or a failure. Do not modify it in any case because it involves a risk.
-  - The operator and maintenance engineer should read the operation manual thoroughly before operating this product and performing maintenance in respect of this product.
-  - Always wear proper safety equipments (facemask, ear plugs, and safety shoes, etc.) when installing, operating and disassembling this product.
-  - Do not use or leave this product in a slope or any unstable locations. The damage only accident and the facilities pollution by the fall of this product might occur if this product is used in an unstable place. Such a secondary disaster becomes a responsibility on the user side.
-  - Make ground connection when working with flammable material or in explosive atmosphere. Rapid pumping of material can result in static electrical charge. Also, be sure to provide proper ventilation where a flammable atmosphere may exist.
-  - Execute the daily checkup.
-  - Use this product according to the product specification.
-  - Attach a valve (for stop in emergency) or regulator to the air supply pipe to keep supply air pressure under 0.7 MPa.
-  - Be careful not to drop this product when lifting it up to replace a pail. Catching a falling product may cause hand injury by its edge.
-  - Turn off the air supply to stop pump operation when removing the pump from a pail. Being caught in a shovel, the lowest part of the pump, can cause hand injury and malfunction of the pump.
-  - Discontinue it when you feel a hazard or abnormality during the work. And correspond according to the troubleshooting.
-  - Stop pump operation immediately when a drum becomes empty. Running the pump dry will cause excessive vibration, resulting in reduction of pump life and damage to other equipment.
-  - Be very careful not to drop the grease gun. It may become damaged, resulting in leakage and malfunction.
-  - Before maintenance operation, be sure to stop air from being supplied to the pump, and release the internal pressure (both air and material) of the pump. There is danger such as spouting of the material when the maintenance work is done with air supplied.
-  - Do not discharge material directly onto the ground. Dispose of harmful materials according to the requirements specified in SDS or local regulations. Also, dispose of this product according to the local regulations after removing residual material from inside this product. (Please contact industrial waste disposal service.)

 **CAUTION**









-  - Keep hands and fingers away from this product during operation to avoid injury from moving parts.
-  - Use this product for the material suitable for the specification. Parts may be corroded and material leak from the damaged parts can lead to environmental pollution. Also, follow handling notes (SDS) of the manufacturer about the handling of the material used.
-  - Take protective measures against rainwater and dust. It is likely to lead to the pollution of the material.
-  - Be careful about your hands when mounting/dismounting the cabinet or installing a pail. The edges of this product and pail may cause hand injury. Also, be careful about your posture when moving this product or lifting it to avoid back injury.
-  - Material remaining inside or on the surface of the pump may spill out by inserting or removing the pump into/from a pail. Be very careful not to get your clothing dirty.
-  - Do not touch the surfaces of the pump and the hose when pumping high-temperature material. Risk of burns exists.
-  - Be careful when handling the grease gun. Avoid finger injury from being caught between the lever and gun. The finger might be injured.
-  - Stop the air supply source after the end of work when not using this pump for a long time such as nighttimes and holidays. Also, open the valve of the exhalation port and liberate pressure in the pump and the hose. There is a possibility of polluting facilities because of the damage of the hose and the leakage of the valve. Such a secondary disaster becomes a responsibility on the user side.

Table of Contents

- Preface	
- For Safe Operation	
- Warnings and Cautions	
- Precautions on Use	
1. Names and Materials of Parts	
1.1 Names and Materials of Parts	1
1.2 Contents of Package	1
2. Principle of Operation	
2.1 Function of the Air Motor	2
2.2 Function of the Lower Pump	2
3. Preparations before Operation	2
4. How to Operate the Machine	4
5. Maintenance and Inspection	
5.1 Troubleshooting and Corrective Measures	5
5.2 Maintenance and Inspection	5
6. Disassembly and Assembly	6
7. Parts Disassembly Drawing and Parts List	
7.1 880873 KPL-55EX	7
7.2 852765 Pump Assembly	7
7.3 851985 Grease Gun	8
8. Specification	9
9. Limited Warranty	10

1. Names and Materials of Parts

1.1 Names and Materials of Parts

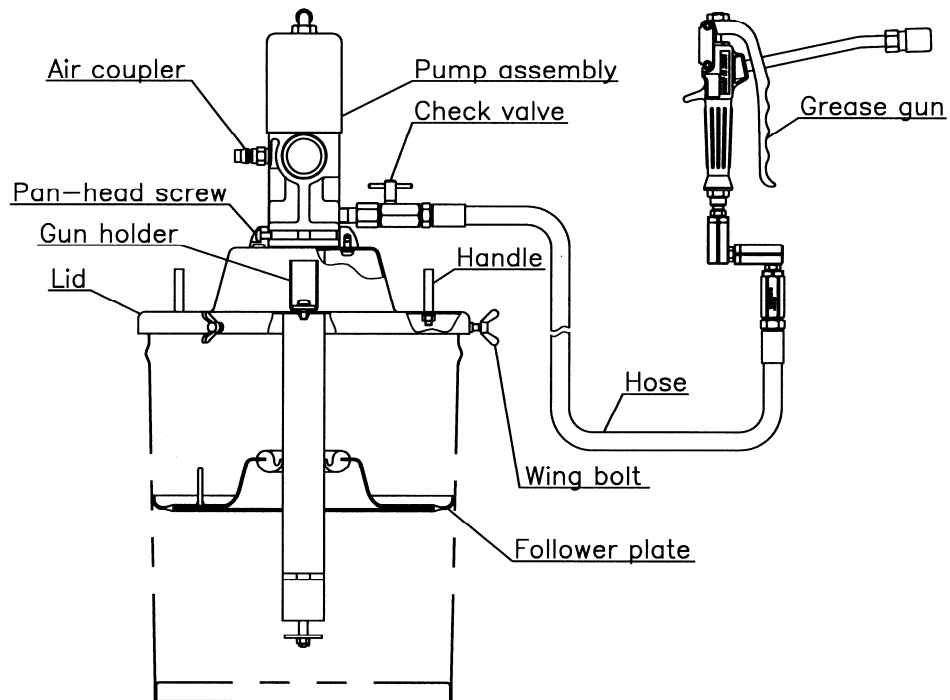

1.2 Contents of Package

This machine is packaged in a corrugated fiberboard case.

Please make sure no damage during shipment and no missing accessories after unpacking as soon as possible.

Please make sure no loose screws, piping connections, and fastener components.

Please retighten if any screws, piping connections, and fastener components are loose.

2. Principle of Operation

The YAMADA Air-powered Pump is a reciprocating type pump that is driven by compressed air. This pump consists of an air motor to drive the pump and a lower pump to draw up the liquid material as shown in the figure.

2.1 Function of the Air Motor

- 1) In the status shown in the figure at right, the air piston reaches the upper limit and is now about to go down.
- 2) The compressed air fed from the air supply port is applied to the chamber A through the air passage tube from the path provided in the lower part of the slide valve. The air pressure of the chamber B is discharged out through the slide valve.
- 3) As a result, the air piston starts to go down.
- 4) When the air piston collides with the trip shoe, the slide valve is momentarily tripped downward by the function of the trip mechanism.
- 5) As a result, the air supply is conducted to the chamber B and the chamber A is conducted to the exhaust port, so that the air piston is changed to go up.
- 6) Thus, the air motor continues its reciprocating motion automatically as long as the supply air is fed to it.

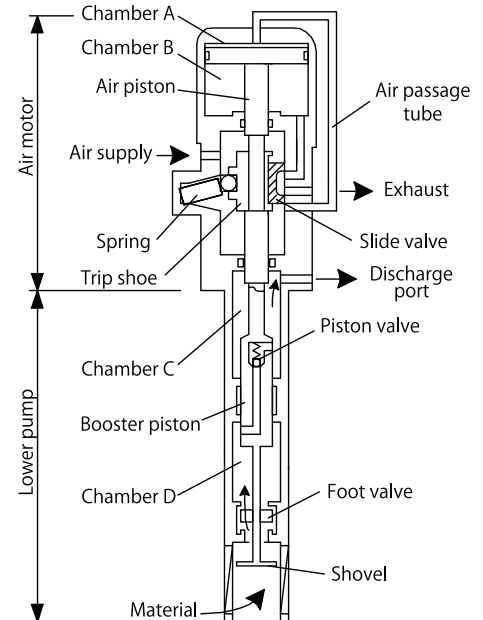

2.2 Function of the Lower Pump

- 1) The lower pump integrated with the air motor traces the reciprocating motion of the air motor.
- 2) The shovel performs mixing so that grease may be easily sucked into the pump, and squeezes it into the foot valve.
- 3) Because the chamber D has a sectional area difference of the booster piston, it sucks the grease from the shovel at the ascending motion. At the descending motion, the foot valve is closed, so that the grease of the chamber D is fed out to the chamber C.
- 4) Because the chamber C leads to the discharge port, the grease is intermittently discharged to the delivery side.
- 5) This reciprocating motion is automatically continued until the delivery side is closed and the material compressive force of the chamber C and chamber D is completely balanced with the pressure of the air motor.

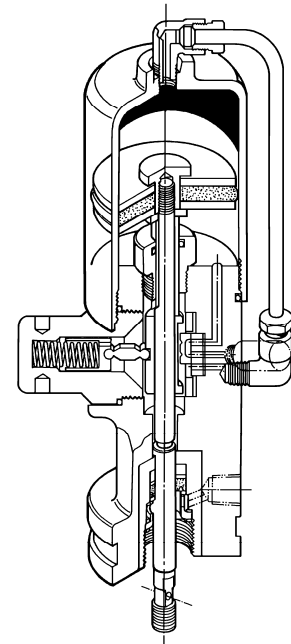

3. Preparations before Operation

⚠ CAUTION



- Apply sealing compound or sealing tapes to the male screws and tighten tightly when the pipes are connected. Be careful not to allow the sealing materials to enter the piping.
(However, no applying is necessary if it will be connected to the hose union.)
Check that there is no leakage from each part after connecting the piping.

[Assembling the unit] (Fig. 1)

- 1) Insert the pump assembly in the center hole from the front side of the lid.
- 2) Fix the pump assembly and the lid with 3 pan-head screws from the rear side of the lid.
- 3) Connect the high-pressure hose for grease (separately available) to the check valve at the pump discharge port and connect a high-pressure grease gun to the other end of the hose. (Fig. 2)

[Setting the pump]

- 4) Remove the lid of a new pail and set the attached follower plate. Place the follower plate on the grease horizontally and push it down by rubbing it to left and right with a hand until the grease comes out from the packing in the middle of the plate. (Fig. 3)

<NOTE>

When using the follower plate for the first time after purchasing the product, pack grease beforehand in the rear-side concave portion of the plate. This facilitates the work. (Fig. 4)

- 5) Insert the pump in the packing in the middle of the follower plate and set the lid on the pail. Fix it securely by screwing 3 wing bolts equally.

<NOTE>

Take extreme care not to allow sand and dust to adhere on the suction tube and follower plate of the pump assembly. Do not blemish the packing of the follower plate by the end of the lower pump.

[Bleeding air for grease]

- 6) Connect the air hose from the compressor to the air chuck of the pump to supply air. The pump is operated for a while. When the pump and the hose are filled with grease, they stop.
- 7) The first applied grease includes the internal air of the pump. This is not a good condition. Obtain a perfect condition by the next operation. First open the check valve and operate the pump until grease is discharged from a small hole under the check valve. After grease is discharged in a perfect condition, close the check valve. At this time, spread paper so that grease may not come into touch with the hand, and dispose of the discharged grease. (Fig. 5)

<NOTE>

The grease in which air is mixed is cloudy in white

- 8) Discharge the air-mixed grease completely from the high-pressure grease gun and the hose by pulling the gun lever.
- 9) Set the supply air pressure to 0.5 - 0.7 MPa.

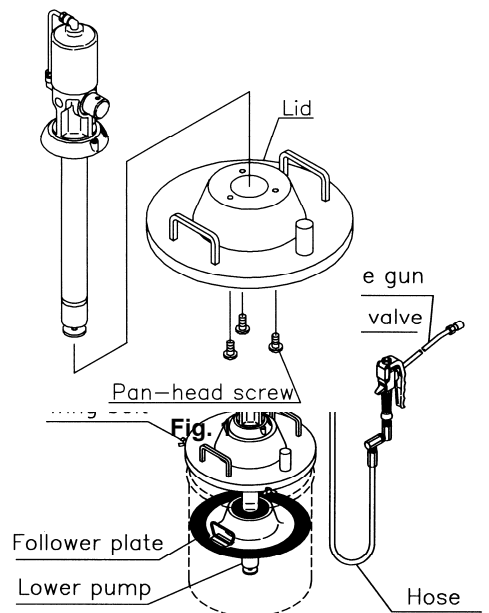

Fig. 2

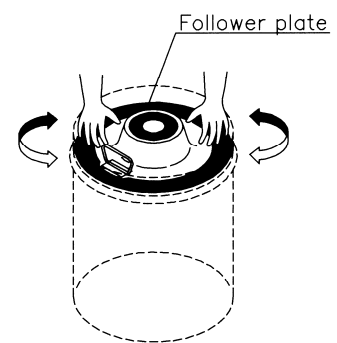

Fig. 3

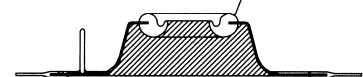

Fig. 4

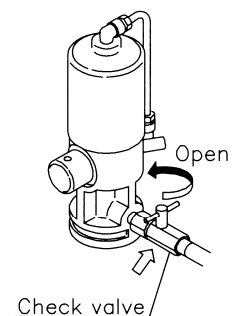







Fig. 5

CAUTION



- The maximum supply air pressure of this machine is 0.7 MPa. Using the machine with a supply air pressure exceeding this limit will lead to death or bodily injury or physical damage due to machine breakage. Do not set the supply air pressure over 0.7 MPa in any case.

4. How to Operate the Machine

 CAUTION	
	- Do not operate the gun lever with the discharge port facing to another person during machine operation. A direct hit against the human body may result in an accident such as skin damage.
	- The maximum operating air pressure of this machine is 0.7 MPa. Using the machine over this pressure may result in a bodily accident or physical accident due to damage. Do not operate the machine over 0.7 MPa. If the air line is 0.7 MPa, reduce the air line to 0.7 MPa or less by using the air regulator.
	- Regarding a secondary accident such as hose damage that may be caused without shutting off of the air supplied to the hose or installation contamination due to a leak from the valve or gun after completion of the work or at night, the responsibility rests with the user side.
	- When the pump causes a malfunction or operation stop, do not disassemble the pump thoughtlessly and disassemble only necessary portions referring to the item pertaining to "5.1 Troubleshooting and Corrective Measures" and judging the situation properly.

- 1) Wipe the grease nipple to be used for greasing completely. After that, push the hydro chuck of the high-pressure grease gun against the nipple to perform chucking as vertically as possible. (Fig. 6)
- 2) Pull the lever of the high-pressure grease gun to supply grease. The pump is automatically operated to supply grease. When grease is normally injected, old grease will be squeezed out from the groove or clearance bear the nipple.
- 3) After completion of grease supply, release the gun lever. The grease supply will be stopped and the pump will also be stopped automatically.
- 4) Remove the hydro chuck of the grease gun. Since pressure is applied to the hydro chuck, the head of the nipple may be broken if it is suddenly pulled. Incline the hydro chuck to bleed the internal pressure and loosen the claw bite, and the chuck can be easily removed. (Fig. 7)
- 5) After completion of greasing work or when the pump is not used for a long time, be sure to shut off the supply air and bleed the internal air of the pump, grease gun, and hose by operating the gun lever.
- 6) If the pump is suddenly started, it may be due to non-existence of grease in the pail or a cavity produced. Stop the greasing work and make a check. If the grease is used up, replace the pail.

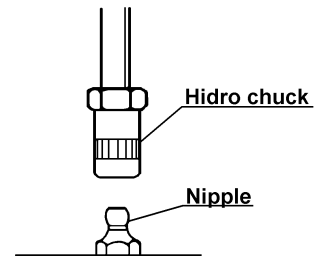

Fig. 6

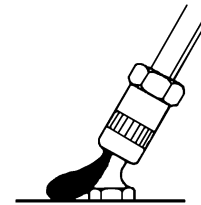



Fig. 7

[Replacing the pail]

 CAUTION	
	- When replacing the pail, be sure to shut off the supply air for safety and pull the gun lever to bleed the internal pressure of the pump and hose beforehand.

- 7) Unscrew the 3 wing bolts of the lid, and remove the pump unit from used the pail and take out the follower plate.
- 8) Remove the lid of a new pail and place the follower plate on the grease horizontally and push the follower plate by rubbing it until grease comes out from the central hole.
- 9) Insert the pump in the packing in the middle of the follower plate and set the lid on the pail. Screw the 3 wing bolts equally so fix the lid securely.

5. Maintenance and Inspection

5.1 Troubleshooting and Corrective Measures

Symptom	Contents of inspection	Corrective measure
The pump fails to start.	<ul style="list-style-type: none"> - Check if the air regulator is normally operated. - Check if the valve in the course of the pipe is not closed. <p style="text-align: center;">↓</p> <p>(Remove the material hose at the pump-side outlet and operate the pump.)</p> <ul style="list-style-type: none"> → If the pump is operated, the material hose, pipe, or outlet valve (gun) is clogged, or the operating pressure is low. → If the pump is not operated, the pump is defective. <p style="text-align: center;">↓</p> <p>(Separate the lower pump and operate the pump with only the air motor.)</p> <ul style="list-style-type: none"> → If the pump is operated, the lower pump is defective. → If the pump is not operated, the air motor is defective. 	<ul style="list-style-type: none"> → Pressure check. (0.3 - 0.7 MPa) → Inspection → Repair service for the lower pump → Repair service
The pump fails to stop.	<ul style="list-style-type: none"> - Check if the pump cannot be stopped when the material outlet side remains open. - If the outlet side is closed, check if any leak occurs at the pipe, material hose, or each connecting portion. - Check if the air bleed valve or bleeder valve remains open. - Check if there is no material. 	<ul style="list-style-type: none"> → Inspection → Replenishment
The pump is operated but does not feed the material by pressure.	<ul style="list-style-type: none"> - Loosen the air bleed valve to bleed the air staying under the inductor plate and tighten the valve again. - If the pump cannot be operated, open the bleeder valve. When the material comes out, tighten the valve again. - If the material is not fed, disassemble the check valve and clean and check the ball seat surface and spring. - The pump cannot be operated yet, the pump is defective. 	<ul style="list-style-type: none"> → Inspection → Inspection → Disassembly and inspection → Repair request for the lower pump
The pump is operated but the pressure and flow rate are insufficient.	<ul style="list-style-type: none"> - Check if the supply air pressure is insufficient. - Check if the packing of the air valve is not worn away. 	<ul style="list-style-type: none"> → Pressure check → Repair request for the lower pump

5.2 Maintenance and Inspection

[Oiling]

For lubrication of the pump, perform oiling with a lubricant once every 10 days. Apply the lubricant as follows. (Fig. 8)

- 1) Remove the air regulator.
- 2) Inject several drops (approx. 0.5 mL) of lubricant to the air supply port as shown in the figure at right. Use turbine oil first class ISO (VG-32) as the lubricant.

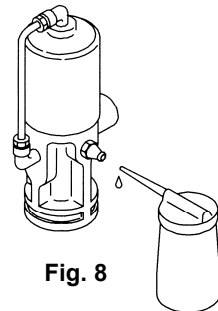

Fig. 8



[Inspection]

The hose is a consumable part. Check it periodically. If any blemish or leakage is found, replace the hose little earlier. The packing and slide portion parts of the pump are worn away. Check and replace them once a year.

<NOTE>

When washing parts, do not use such a liquid as corrodes aluminum, copper alloy, iron, etc.

6. Disassembly and Assembly

 CAUTION	
	- Gasoline is a high volatile fuel. Do not use it to clean the pump in any case, otherwise ignition or explosion may be caused.
	- Before disassembling and inspecting the machine, be sure to stop the supply air and open the outlet valve to release the internal pressure of the pump.

- ※ If the foot valve is clogged with dust or the like, perform disassembling, washing, and inspection according to the following procedure.
- ※ For disassembling parts other than the foot valve and the air motor, ask the dealer for disassembly.

[Disassembling the foot valve]

- 1) Bleed the internal pressure of the pump and hose and remove the air chuck and high-pressure hose from the pump.
- 2) Unscrew the pan-head screw of the body supporter that fixes the pump. Pull out the pump from above. (Fig. 9)
- 3) Fix the main body of the pump on the vise and set a spanner on the valve adapter. Set a pipe wrench on the tube and unscrew the tube.
- 4) Pull out the split pin that fixes the plate and unscrew the nut. The plate can be removed. (Fig.10)
- 5) Set a spanner on the valve adapter and unscrew it. The out-tube can be pulled out and the valve seat, foot valve, and washer can be taken out from the inside of the suction tube.
- 6) If they are hard to take out, set a pipe wrench on the knurling of the suction tube and unscrew the suction tube.
- 7) Pull apart the suction tube a little, and the union connecting between the air motor and the rod becomes visible. Pull out the pin and unscrew it for removal. (Fig.11)
- 8) The air motor is separated from the lower pump. The valve seat, foot valve, and washer can be taken out from the inside of the suction tube. (Fig. 12)
- 9) Wash and check each part. If any blemish or wear is found, replace the part with a new one. In particular, pay attention to filter clogging in valve adapter.
- 10) For assembling, reverse the disassembling procedure. At this time, perform inspection taking care about the directions of the valve seat and foot valve.

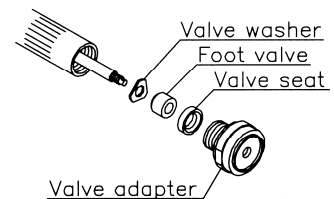
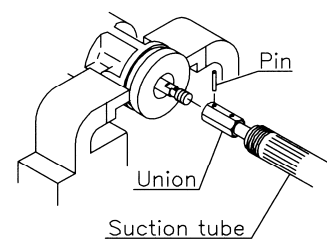
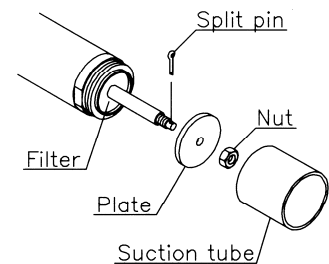
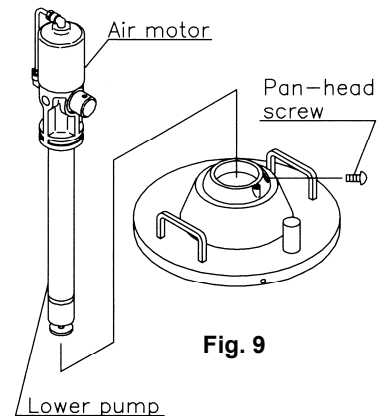

7. Parts Disassembly Drawing and Parts List

7.1 880873 KPL-55 EX

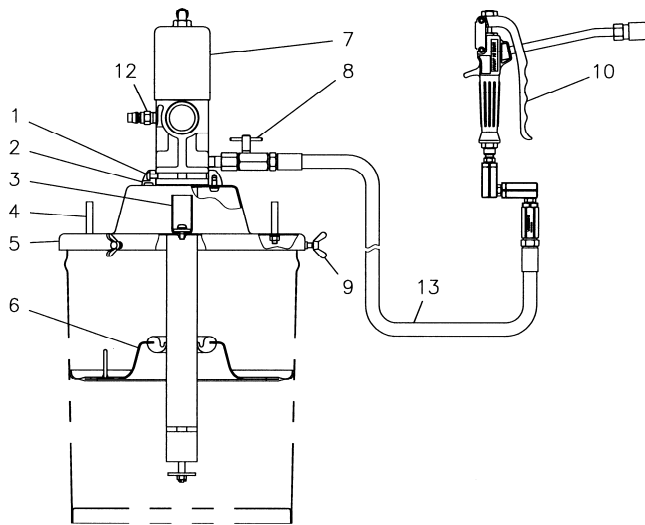

REF.No.	Parts No.	Description	Q'ty
1	602296	Pan-head screw	4
2	702743	Pump mounting flange	1
3	707937	Gun holder	1
4	681675	Handle	2
5	710915	Lid	1
6	802161	Follower plate	1
7	852765	Pump assembly	1
8	800766	Check valve	1
9	610623	Wing bolt	3
10	851985	Grease gun	1
12	680743	Air coupler (plug)	1
13	695034	Hi-pressure hose	1

7.2 852765 Pump assembly

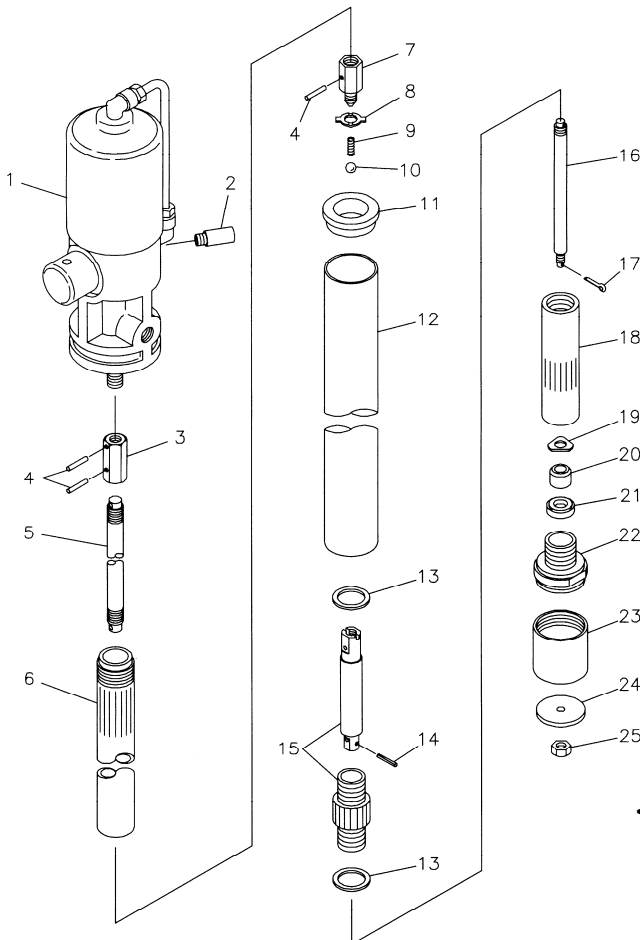

REF.No.	Parts No.	Description	Q'ty
1	802630	Air motor	1
2	681170	Silencer	1
3	706091	Union	1
4	702971	Pin	3
5	709643	Rod	1
6	709642	Suction tube	1
7	702975	Union	1
8	702974	Washer	1
9	702976	Spring	1
10	630313	Ball	1
11	770409	Packing	1
12	709597	Out tube	1
13	702977	Washer	2
14	632754	Spring pin	1
15	803355	Cylinder assembly	1
16	706399	Plunger	1
17	632019	Split pin	1
18	706072	Foot tube	1
19	702980	Valve washer	1
20	771404	Foot valve	1
21	702982	Valve seat	1
22	830407	Valve adapter assembly	1
23	709644	Tube	1
24	702984	Plate	1

<Note>

If disassembly is required, ask the dealer to disassemble the air pump. As for the specialist of the dissolution, refer to the instruction manual.

(Separately APP006U: Instruction for Grease Pump)

7.3 851985 Grease gun

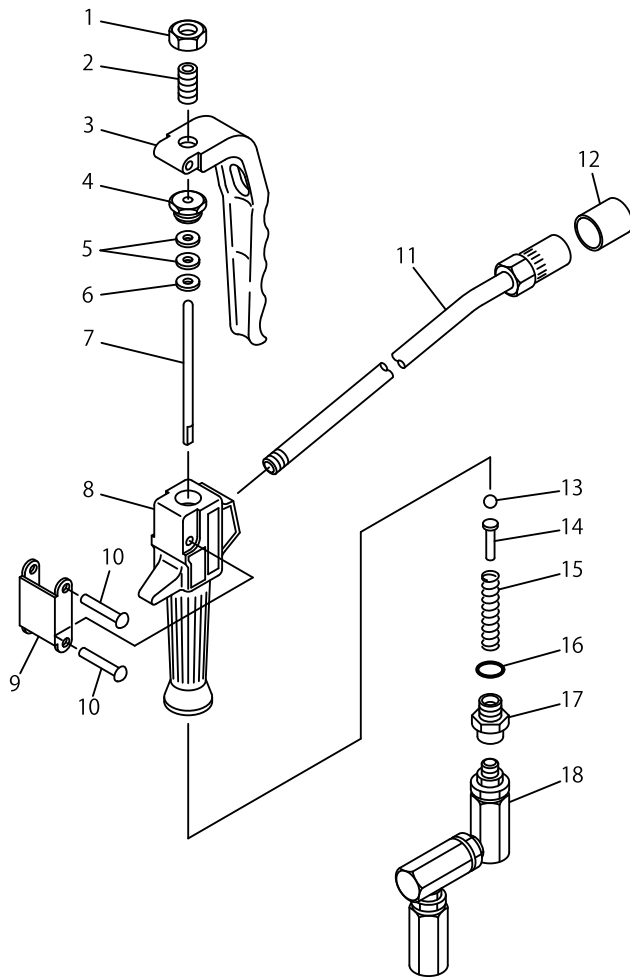

REF.No.	Parts No.	Description	Q'ty
1	627641	Nut	1
2	711750	Bolt	1
3	711354	Lever	1
4	711444	Retaining nut	1
5	772160	Packing	2
6	713638	Washer	1
7	711357	Rod	1
8	711352	Body	1
9	711351	Link	1
10	683201	Rivet	2
11	804911	Nozzle	1
12	685728	Cap	1
13	630314	Ball	1
14	711445	Spring retainer	1
15	711446	Spring	1
16	640011	O ring	1
17	710971	Union	1
18	802910	Swivel joint assembly	1

★REF No.3, 8, 9 and No.10 are undissolution.

8. Specification

■ Engineering Data

TYPE		KPL-55 EX
ITEM No.		880873
PUMP RATIO (NOMINAL)		55 x 1
MATERIAL CONNECTION	DISCHARGE PORT	High pressure grease gun
AIR CONNECTION	SUPPLY PORT	Coupler plug,PS-20PM
OPERATING AIR PRESSURE		0.2 - 0.7 MPa
MAXIMUM OPERATING NOISE	A-WEIGHTED SOUND PRESSURE LEVEL *1	86 dB
	A-WEIGHTED SOUND POWER LEVEL *2	96 dB
AMB. TEMP. RANGE	TEMP. AMBIENT	0 - 60 °C
	TEMP. MATERIAL	0 - 80 °C
WEIGHT		8.7 kg
ACCESSORIES		695034 High-pressure hose 1/4×2.5 m 851985 Grease gun 680743 Air coupler 802161 Follower plate

*1 Measurement method of A-weighted sound pressure level is based on ISO 1996.

*2 Measurement method of A-weighted sound power level is based on ISO 3744.

■ Performance Curve (only the pump)

<NOTE>

The continuous pump operation should be avoided if the desired delivery is in the range shaded in the figure below.

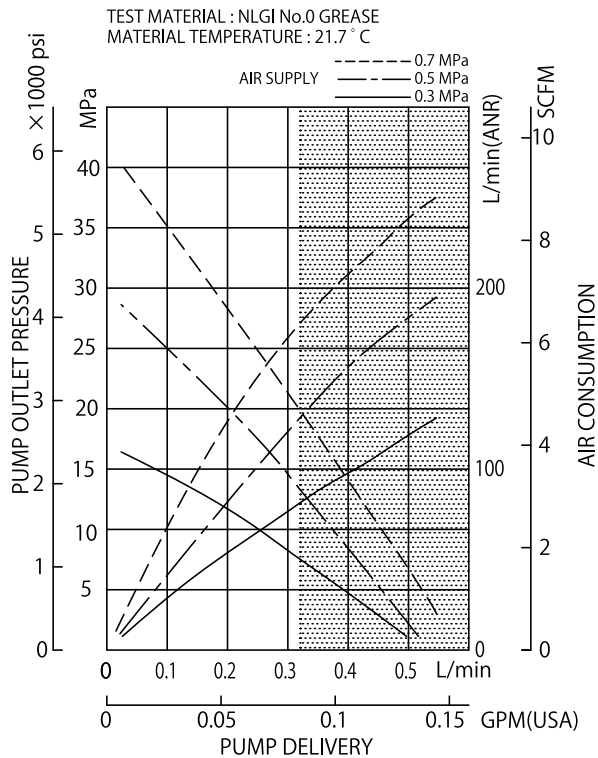

■ Dimensions

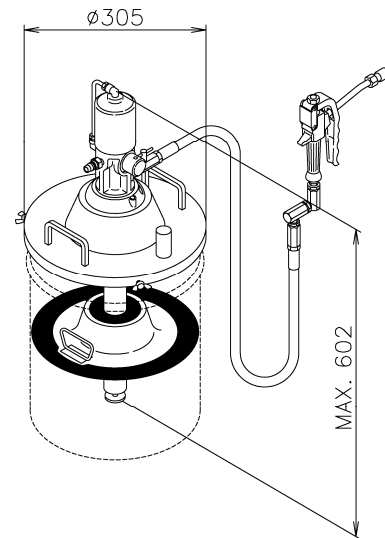

9. Limited Warranty

If an abnormality occurs during normal operation in accordance with the operating instructions and other operating cautions within the warranty period (12 months after date of purchase) that can be attributed to a manufacturing defect, the defective parts of this product will be serviced or the product will be replaced free of charge. However, this warranty will not cover compensation for incidental damage or any malfunction listed below.

1. Warranty period

This warranty will be valid for a period of 12 months after the date of purchase.

2. Warranty

If, during the warranty period, any of the material of the genuine parts of this product or the workmanship of this product is found defective, and is so verified by our company, the servicing cost will be fully born by our company.

3. Exclusion

Even during the warranty period, this warranty does not cover the following.

- 1) Malfunction arising from use of parts other than manufacturer-specified genuine parts
- 2) Malfunction arising from misuse or operating errors, or lack of storage or maintenance care
- 3) Malfunction arising from use with a fluid that may cause corrosion, inflation or dissolution of the component parts of the product
- 4) Irregularity arising from repair made by other than by our firm, our regional office, dealer or authorized service personnel
- 5) Malfunction arising from modification of the product by other than authorized service personnel
- 6) Wear and tear of parts that must be regularly replaced in the course of normal operation, such as packings, O-rings and hose.
- 7) Malfunction and/or damage due to use with incorrect voltage.
- 8) Malfunction and/or damage due to transportation, moving or drop page of the product after purchase
- 9) Malfunction and/or damage due to fire, earthquake, flood or other force majeure
- 10) Malfunction arising from use of compressed air that contains impurities or excessive moisture, or use of gases or fluids other than the specified compressed air
- 11) Malfunction arising from use of excessively abrasive material or of inadequate grease.

Furthermore, this warranty does not cover the rubber parts, or other parts used in this product and its accessories, which are subject to wear in normal operation.

- hoses
- packings
- cords

4. Parts

Parts for this product will be kept available for 5 years after discontinuation of production. Once 5 years have elapsed after close of production, availability of parts for this product cannot be guaranteed.

MEMO.

YAMADA EUROPE B.V.

Aquamarijnstraat 50,7554 NS Hengelo (O),The Netherlands

PHONE : +31-(0)74-242-2032

FAX : +31-(0)74-242-1055

E-mail : sales@yamada.nl

Web : www.yamada-europe.com

Manufactured by

YAMADA CORPORATION

INTERNATIONAL DEPARTMENT

1-1-3, Minami-Magome,Ota ku, Tokyo, 143-8504, Japan

PHONE : +81-(0)3-3777-0241

FAX : +81-(0)3-3777-0584

E-mail : intl@yamadacorp.co.jp

Web : www.yamadacorp.co.jp