

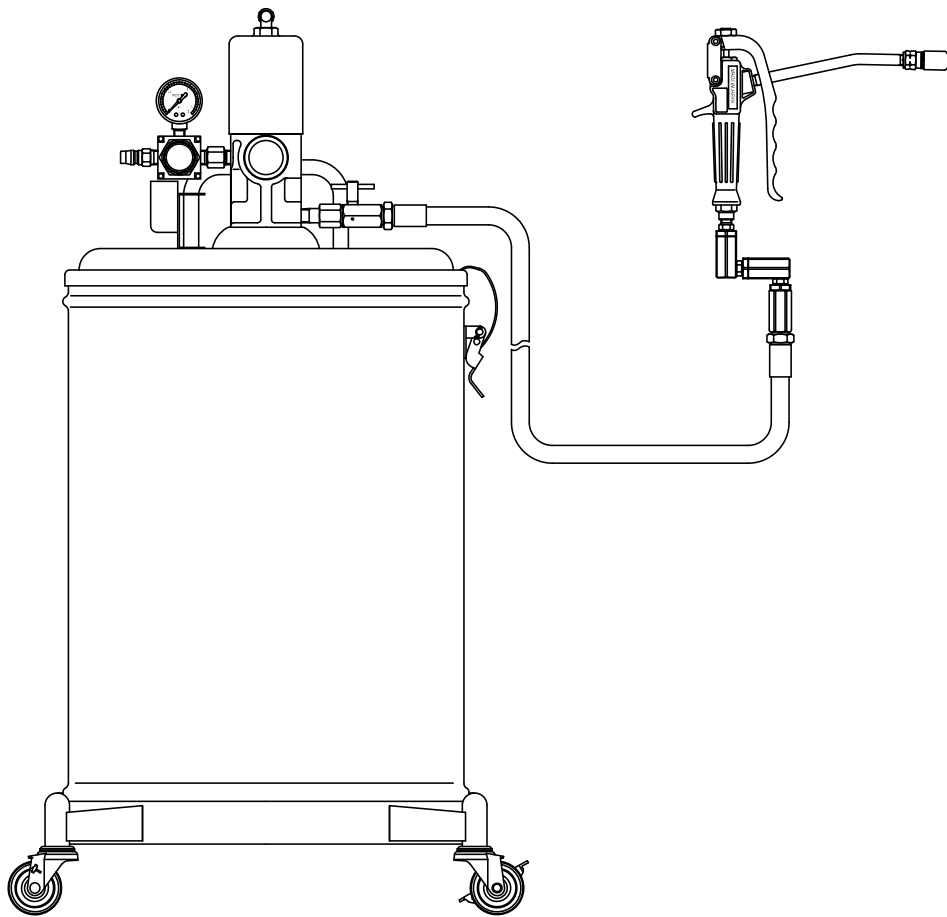

# OPERATION MANUAL

## GREASE LUBRICATOR

SKR- 66    ITEM No.880877



### **WARNING**

Prior to operating this pump, be sure to read this operation manual for safety. After reading the manual, please keep it at hand any time for your quick reference.

# YAMADA CORPORATION

## EC DECLARATION OF CONFORMITY

Name of company : YAMADA CORPORATION

Address : 1-1-3, Minami-Magome, Ota ku, Tokyo, 143-8504 Japan

declares, in sole responsibility, that the following product

Equipment : GREASE LUBRICATOR

Type : SKR-66 series

Referred to in this declaration conforms with the following standard(s) or directive(s) :

- Directive 2006/42/EC
- EN-ISO 12100:2010
- EN 809:1998 + A1:2009

YAMADA CORPORATION will keep on file for review the following technical documentation :

- operating instructions as required
- plans
- description of measures designed to ensure conformity
- other technical documentation

Importer / Distributor in EU

Name of company : YAMADA EUROPE B.V.

Atsushi Yamaguchi (Managing Director)

Address : Aquamarijnstraat 50, 7554 NS Hengelo (0), The Netherlands

Place and date issued : Sagamihara Factory / December 16, 2019

Name and signature as well as position of undersigned :

Kotaro Yamada (Director, Sagamihara Factory)



K. Yamada

## - Preface

Thank you for purchasing a Yamada Pump. This machine is a portable type lubricator that is indispensable for grease lubrication for machines and vehicles. This lubricator cannot be used for oil lubrication.

The applicable grease is limited to a type of NLGI No.2 or less in the normal operating conditions.

- If the lubricator is used in an extremely cold or low-temperature environment, the discharge volume will be remarkably lowered.
- Silicone grease is not applicable.

## - For Safe Operation

This manual describes the items that are important for the user to operate this product safely, correctly, and efficiently. Before operating this product, read this manual thoroughly, in particular, "Warnings and Cautions" at the beginning of this manual.

## - Warnings and Cautions

For safe use of this product, be sure to note the following: In this document, warnings and cautions are indicated by symbols. These symbols are for those who will operate this product and for those who will be nearby, for safe operation and for prevention of personal injury and property damage. The following warning and caution symbols have the meanings described below. Be sure to remember their meanings.



**WARNING** : This indicates the existence of potential hazard which, if not avoided, will result in death or serious injury.



**CAUTION** : This indicates the existence of potential hazard which, if not avoided, may result in bodily injury or in physical damage.

Furthermore, to indicate the type of danger and damage, the following symbols are also used along with those mentioned above:







This symbol indicates a DON'T, and will be accompanied by an explanation on something you must not do.









This symbol indicates a DO, and will be accompanied by instructions on something you must do in a certain situation.

## - Precautions on Use

The following warnings and cautions are very important. Be sure to observe them.

 <b>WARNING</b>	
	- If the material handled come into direct contact with or is splashed over your body, it could be harmful to the eye or skin. Be sure to check the material handled, and when you work with it, put on a protective gear (protective mask, glasses, safety gloves, etc.) depending on the degree of danger.
	- Some types of grease may contain a carcinogenic material. Read the cautions for handling grease given by the grease maker carefully when handling the grease.
	- Gasoline is a high-volatility material. Do not use gasoline to clean the pump in any case, otherwise it may cause ignition or explosion.

 <b>CAUTION</b>	
	- <b>Restriction on handling</b> The operator or administrator of this pump should not allow those who have no knowledge of the pump to operate it.
	- The maximum supply air pressure of this machine is 0.7 MPa. Using the machine with a supply air pressure exceeding this limit will lead to death or bodily injury or physical damage due to machine breakage. Be sure to adjust the supply air pressure below 0.7 MPa.
	- After the end of daily work, at night, and on holidays, be sure to shut off the supply air to this machine to release the gun so as to bleed the internal pressure. Any secondary accident such as pollution of installation, due to pump operation driven by worn-away packing or hose without shutting off the supply air, shall be attributable to the user's responsibility.
	- Do not operate the gun lever with the discharge port facing to another person during machine operation in any case. A direct hit against the human body may result in an accident such as skin damage.
	- During machine operation or after completion of movement, be sure to lock the caster brake for locking.
	- When replacing any part at maintenance, be sure to stop the air supply to the machine to avoid having fingers nipped because of a malfunction.

# Table of Contents

- Preface	
- For Safe Operation	
- Warnings and Cautions	
- Precautions on Use	
<b>1. Names of Parts</b>	
1.1 Names of Parts .....	1
1.2 Contents of Package .....	1
<b>2. Principles of Operation</b>	
2.1 Function of the Air Motor .....	2
2.2 Function of the Lower Pump .....	2
<b>3. Preparations before Operation</b>	
3.1 Setting a Pail .....	3
3.2 Assembling the Equipment .....	3
3.3 Operating the Equipment .....	4
<b>4. How to Operate the Machine</b> .....	5
<b>5. Maintenance and Inspection</b>	
5.1 Troubleshooting and Corrective Measures .....	6
5.2 Maintenance and Inspection .....	6
5.3 Disassembly and Assembly .....	7
5.3.1 Separating the air motor from the lower pump .....	7
5.3.2 Disassembling the lower pump .....	7
<b>6. Parts Disassembly Drawing and Parts List</b>	
6.1 SKR-66 (880877) .....	9
6.2 Grease Gun (851985) .....	9
6.3 Air Motor (802630) .....	10
6.4 Lower Pump .....	11
<b>7. Specifications</b> .....	12
<b>8. Limited Warranty</b> .....	13

## 1. Names of Parts

### 1.1 Names of Parts

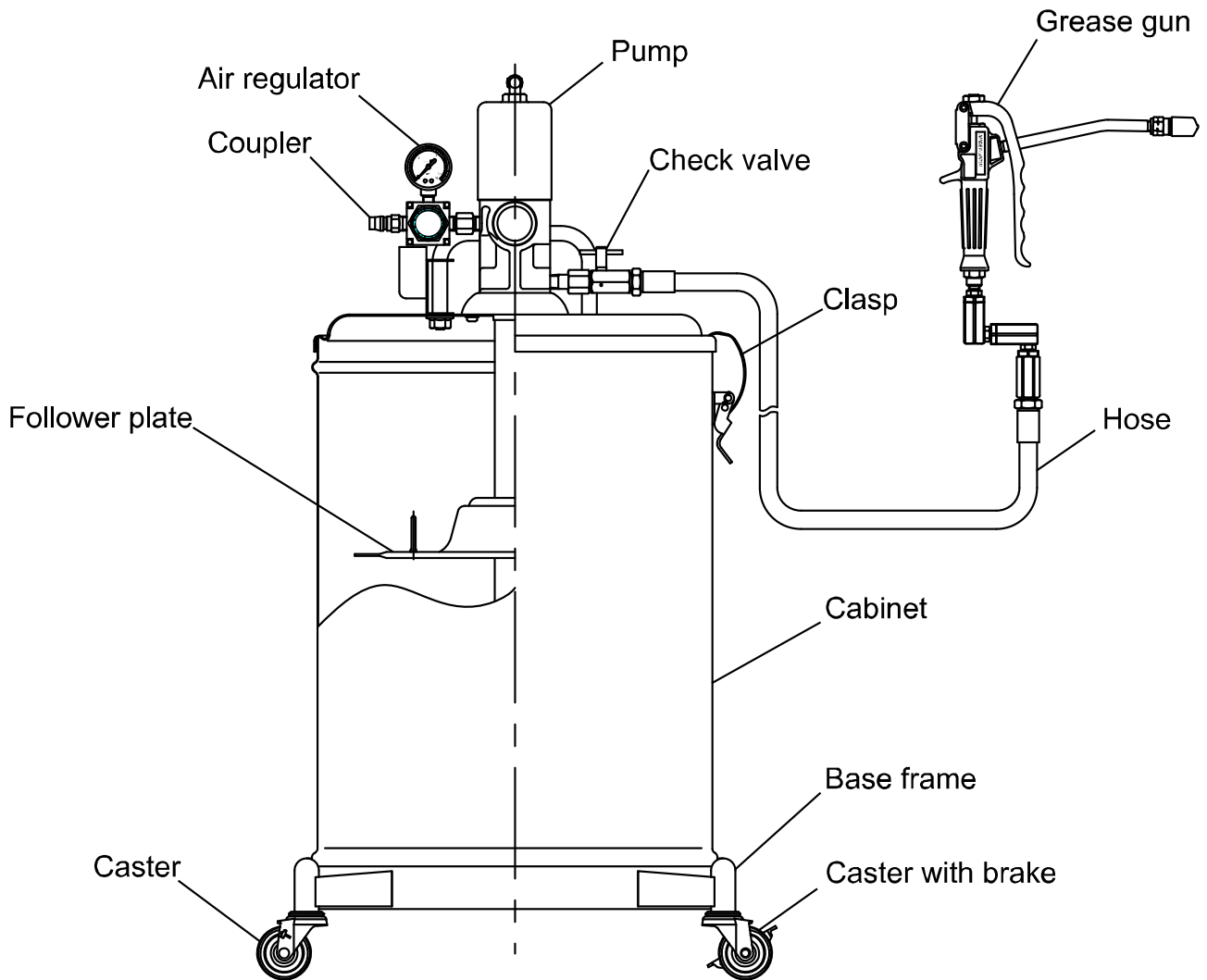

### 1.2 Contents of Package

The main devices and the accessories are packed in different cases.

Please make sure no damage during shipment and no missing accessories after unpacking as soon as possible.

Please make sure no loose screws, piping connections, and fastener components.

Please retighten if any screws, piping connections, and fastener components are loose..

## 2. Principles of Operation

The YAMADA Air-powered Pump is a reciprocating type pump that is driven by compressed air. This pump consists of an air motor to drive the pump and a lower pump to draw up the liquid material as shown in the figure.

### 2.1 Function of the Air Motor

- 1) In the status shown in the figure at right, the air piston reaches the upper limit and is now about to go down.
- 2) The compressed air fed from the air supply port is applied to the chamber A through the air passage tube from the path provided in the lower part of the slide valve. The air pressure of the chamber B is discharged out through the slide valve.
- 3) As a result, the air piston starts to go down.
- 4) When the air piston collides with the trip shoe, the slide valve is momentarily tripped downward by the function of the trip mechanism.
- 5) As a result, the air supply is conducted to the chamber B and the chamber A is conducted to the exhaust port, so that the air piston is changed to go up.
- 6) Thus, the air motor continues its reciprocating motion automatically as long as the supply air is fed to it.

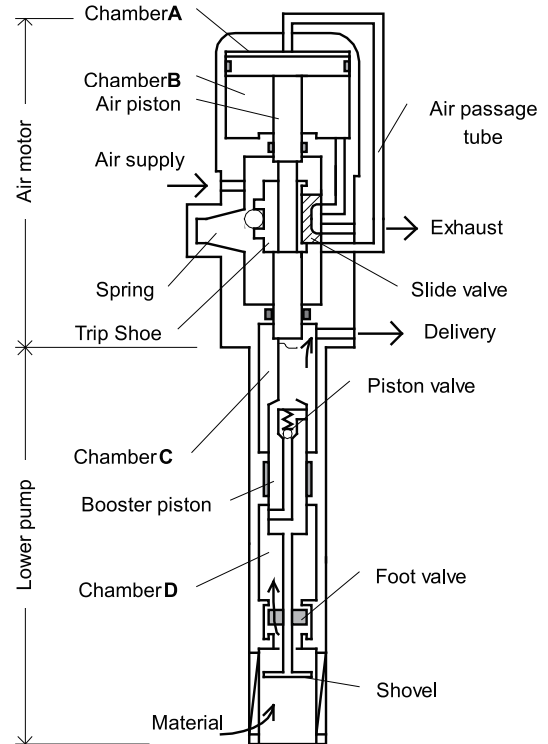

### 2.2 Function of the Lower Pump

- 1) The lower pump integrated with the air motor traces the reciprocating motion of the air motor.
- 2) The shovel performs mixing so that grease may be easily sucked into the pump, and squeezes it into the foot valve.
- 3) Because the chamber D has a sectional area difference of the booster piston, it sucks the grease from the shovel at the ascending motion. At the descending motion, the foot valve is closed, so that the grease of the chamber D is fed out to the chamber C.
- 4) Because the chamber C leads to the discharge port, the grease is intermittently discharged to the delivery side.
- 5) This reciprocating motion is automatically continued until the delivery side is closed and the material compressive force of the chamber C and chamber D is completely balanced with the pressure of the air motor.

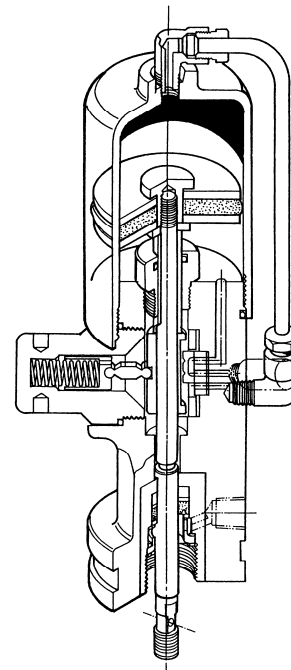

### 3. Preparations before Operation

<b>⚠ CAUTION</b>	
<b>!</b>	<p>- Apply sealing compound or sealing tapes to the male screws and tighten tightly when the pipes are connected.</p> <p>Be careful not to allow the sealing materials to enter the piping. (However, no applying is necessary if it will be connected to the hose union.)</p> <p>Check that there is no leakage from each part after connecting the piping.</p>

#### 3.1 Setting a Pail (Fig. 1)

Fig. 1

1) Release the 3 clasps on the top of the cabinet upward, and the lid can be removed together with the pump.

2) Take out the follower plate in the cabinet.

**<NOTE>**

Take extreme care not to allow sand and dust to adhere on the suction tube and follower plate of the pump Ass'y.

3) Prepare a new pail and remove its lid. Then, set the can in the middle of the cabinet.

4) Set the attached follower plate on the top surface of the grease in the set pail. (For the direction of the follower plate, refer to Fig. 1.)

5) Place the follower plate on the grease horizontally and push it down by rubbing it with a hand until the grease comes out from the packing in the middle of the plate. (Fig. 2)

**<NOTE>**

When using the follower plate for the first time after purchasing the product, pack grease beforehand in the rear-side concave portion of the plate. This facilitates the work. (Fig. 3)

6) Insert the suction tube in the pail so that the suction tube of the pump Ass'y may pass in the middle of the follower plate, put the on the cabinet, and fix the cabinet and the lid with the 3 clasps.

**<NOTE>**

Take care not to blemish the packing of the follower plate by the end of the suction tube.

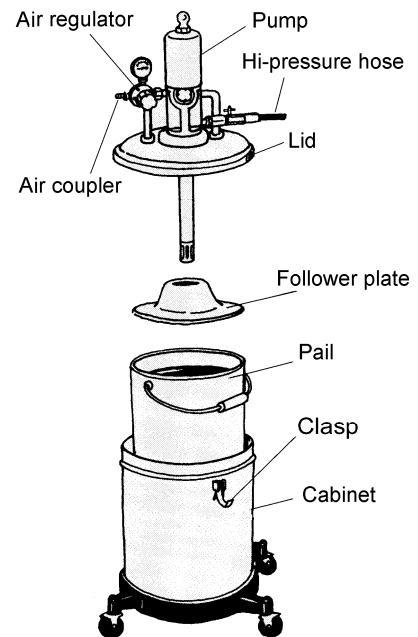

Fig. 2

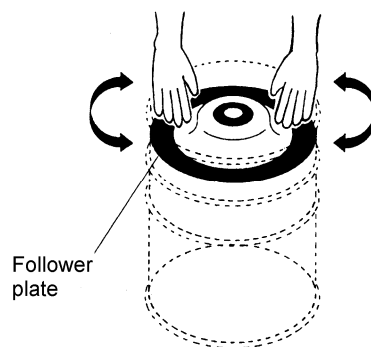
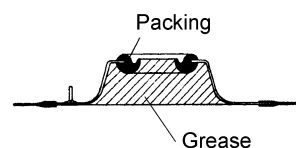

Fig. 3

#### 3.2 Assembling the Equipment

1) Install the attached high-pressure hose and the high-pressure grease gun at the discharge port of the pump, and then install the air regulator at the air supply port. Clamp the connecting portion securely. (Fig. 1)

2) Install the attached air chuck on the air hose (for size 1/4, separately available), and fix it with a hose band. If the connecting air chuck for the compressor side is not available, purchase it separately.



### 3.3 Operating the Equipment

## CAUTION



- The maximum supply air pressure of this machine is 0.7 MPa. Using the machine with a supply air pressure exceeding this limit will lead to death or bodily injury or physical damage due to machine breakage. Do not set the supply air pressure over 0.7 MPa in any case.

- 1) Turn the knob of the air regulator counterclockwise for looseness, and then connect the air chuck to supply air. (Fig.4)

#### <NOTE>

Using an air regulator permits adjusting the supply air pressure to the pump and reducing unnecessary pump motion, thereby improving the work efficiency and extending the life of the pump.

When the knob of the air regulator is turned clockwise, the air pressure will be increased (the indicator of the pressure gauge gradually goes from "0" to a larger number). When the knob is turned counterclockwise, the air pressure will be reduced (the indicator of the pressure gauge goes back to "0"). In the normal operating condition, the indicator of the pressure gauge is in the range of 0.3 - 0.5 MPa.

- 2) As the knob of the air regulator is gradually turned clockwise, the pump is started when the supply air pressure reaches 0.2 or 0.3 MPa. The pump is operated for a while and the pump and hose are filled with grease.

- 3) The first applied grease includes the internal air of the pump. This is not a good condition. Obtain a perfect condition by the next operation.

First open the check valve and operate the pump until grease is discharged from a small hole under the check valve. After grease is discharged in a perfect condition, close the check valve. At this time, spread paper so that grease may not come into touch with the hand, and dispose of the discharged grease. (Fig. 5)

- 4) Set the supply air pressure to 0.5 - 0.7 MPa.

#### <NOTE>

The grease in which air is mixed is cloudy in white.

Fig. 4

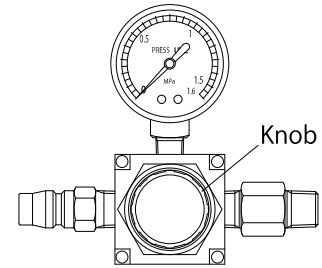
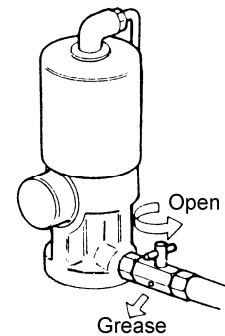

Fig. 5



## 4. How to Operate the Machine

### CAUTION



- The supply air pressure should be 0.7 MPa or less. If the primary pressure is more than 0.7 MPa, adjust the pressure to 0.7 MPa or less.



- After the end of daily work or when the machine is not operated for a long time, be sure to shut off the supply air and bleed the internal pressure of the pump, hose, and gun.



- During machine operation or after completion of movement, be sure to lock the caster brake for locking. (Fig. 6)

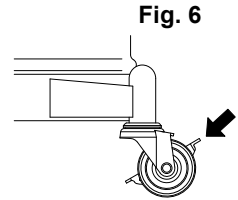

- 1) Wipe the grease nipple to be used for greasing cleanly. After that, push the chuck at the end of the grease gun against the nipple to perform chucking as vertically as possible. (Fig. 7a)
- 2) Pull the gun lever to supply grease. When grease is normally injected, old grease will be squeezed out from the groove or clearance near the nipple.
- 3) After completion of grease supply, release the gun lever. The pump will be automatically stopped.
- 4) Remove the chuck at the end of the grease gun. Since pressure is applied to the chuck, the head of the nipple may be broken if it is suddenly pulled. Incline the chuck to bleed the internal pressure, and the chuck can be easily removed. (Fig. 7b)
- 5) After completion of greasing work, be sure to shut off the supply air of the pump and bleed the internal air of the hose. For bleeding the internal pressure of the pump and hose, Insert the grease gun in the return hole of the lid and pull the gun lever. (Fig. 8)
- 6) If the pump is suddenly started, it may be due to non-existence of grease in the pail or an air pocket produced. Stop the greasing work and make a check.
- 7) Exchange the pail when the grease stopped coming out.

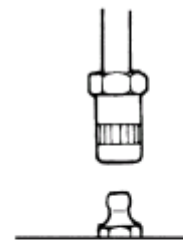

Fig. 7a

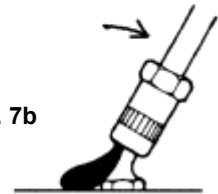
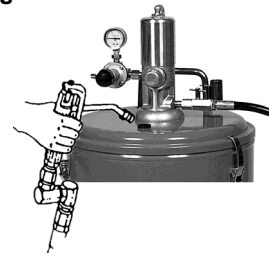

Fig. 7b

Fig. 8



## 5. Maintenance and Inspection

### 5.1 Troubleshooting and Corrective Measures

Symptom	Cause	Contents of inspection and corrective measure
The pump cannot be operated.	<ul style="list-style-type: none"> <li>- Check if the supply air pressure is normal.</li> <li>(Operate the pump with the discharge-side hose removed.)</li> <li>→ If the pump is operated, the outlet valve of the hose is clogged.</li> <li>→ If the pump is not operated, the pump is defective.</li> </ul>	<ul style="list-style-type: none"> <li>- Adjust the supply air pressure between 0.3 and 0.7 MPa.</li> <li>- Ask the dealer to repair it.</li> </ul>
The pump is operated but no grease comes out.	<ul style="list-style-type: none"> <li>- Check if grease is in the pail.</li> <li>- Check if the follow plate is correctly set.</li> <li>- Clogging in the foot valve</li> <li>- Pump failure</li> </ul>	<ul style="list-style-type: none"> <li>- Supply grease or replace the pail with a new one.</li> <li>- Inspection and correction</li> <li>- Inspection and cleaning</li> <li>- Ask the dealer to repair it.</li> </ul>
Grease comes out but the flow rate is low.	<ul style="list-style-type: none"> <li>- Check if the supply air pressure is lowered and if the flow rate is insufficient.</li> <li>- Clogging in the foot valve</li> <li>- Pump failure</li> </ul>	<ul style="list-style-type: none"> <li>- Make an adjustment.</li> <li>- Inspection and cleaning</li> <li>- Ask the dealer to repair it.</li> </ul>
The pump is continuously operated without stop (even if the outlet valve is closed).	<ul style="list-style-type: none"> <li>- Check if leakage is found on the hose or gun for grease and connecting section.</li> <li>- Check if grease is in the pail.</li> <li>- The lower pump is defective.</li> </ul>	<ul style="list-style-type: none"> <li>- Inspection and replacement</li> <li>- Supply grease or replace the pail with a new one.</li> <li>- Ask the dealer to repair the lower pump.</li> </ul>

### 5.2 Maintenance and Inspection

#### [Oiling]

For lubrication of the pump, perform oiling with lubricant once every 10 days. Apply the lubricating oil as follows.

- 1) Remove the air regulator.
- 2) Inject several drops (approx. 0.5 mL) of lubricant to the air supply port as shown in the figure at right. (Fig. 9)  
Use turbine oil first class ISO (VG-32) as the lubricant.

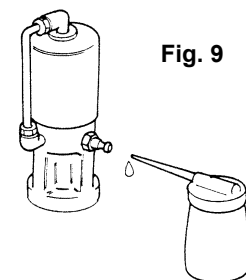

Fig. 9

#### [Inspection]

The hose is a consumable part. Check it periodically. If any blemish or leakage is found, replace the hose little earlier.

The packing and slide portion parts of the pump are worn away. Check and replace them once a year.

⚠ WARNING	
⊘	- Gasoline is a high-volatility material. Do not use gasoline to clean the pump in any case, otherwise it may cause ignition or explosion.



#### <NOTE>

When washing parts, do not use such a liquid as corrodes aluminum, copper alloy, iron, etc.

### 5.3 Disassembly and Assembly

When the pump operation becomes defective or stops, do not disassemble the pump thoughtlessly but judge the condition carefully by referring to the item pertaining to “5.1 Troubleshooting and Corrective Measures”.

The air motor that is not brought into direct contact with the material becomes defective rarely, so it does not need to be disassembled. If disassembly is required, ask the dealer to disassemble the air pump.

<b>⚠ CAUTION</b>	
	- Gasoline is a very volatile fuel. Do not use it for cleaning the pump in any case, otherwise it may lead to ignition or explosion.
	- When disassembling and checking the pump, be sure to stop the supply air and open the outlet valve to release the internal pressure of the pump beforehand.

If the foot valve is clogged with dust, perform disassembling and cleaning according to the following procedure. Regarding other portions other than the foot valve, and the air motor section, ask the service shop authorized by YAMADA to disassemble them.

#### 5.3.1 Separating the air motor from the lower pump

- 1) Bleed the internal pressure of the pump and disconnect the air connection hose, material hose, etc from the pump.
- 2) Unscrew the pan-head screw of the body supporter that fixes the pump. Pull out the pump upward, and the pump can be removed from the cabinet.(Fig.10)
- 3) Fix the air motor body of the pump on a vise. (Fig.11)

**<NOTE>**  
 The air cylinder is easily damaged.  
 Do not fix it on the vise in any case.

- 4) Set a pipe wrench on the knurling part of the suction tube and unscrew the suction tube to remove the suction tube. (Fig. 11)
- 5) Pull out the pin of the piston rod and unscrew the connecting rod to remove it. Then, the air motor and the lower pump can be separated from each other.

Fig. 10

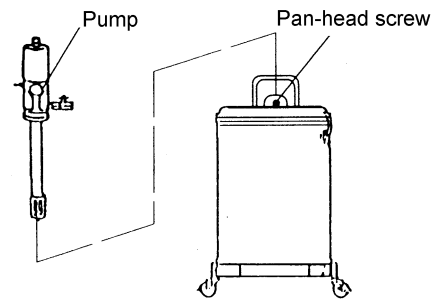
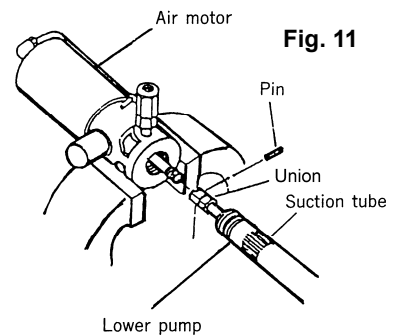

Fig. 11



#### 5.3.2 Disassembling the Lower pump

If check only the foot valve parts, it is unnecessary to remove the air motor, and take the following first.

- 1) After fixed the suction tube with vise, throw a spanner on valve filter and unthread foot tube by a screw driver. Pull cotter pin out to remove the shovel and nut. (See Fig.11,12)  
 - Check plunger rod for breakdown or scratch mark.

Fig. 12

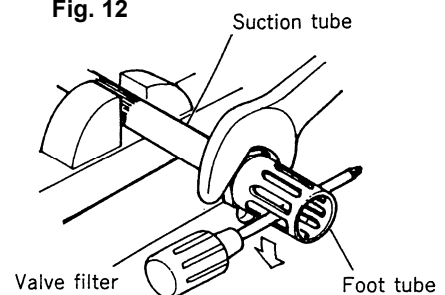

2) Throw a spanner on foot tube and unthread valve filter off. Also, by unscrewing foot tube from the cylinder, foot valve parts will be taken out. (See Fig.13)

- Clean each part and especially check the contacting surface of both foot valve and valve seat for defacement or pit mark. (See Fig.15)

3) Pull the rod assembly out and unscrew union with rod from the piston to pick spring and ball out. Also knock the pin from the low end of piston to unscrew plunger rod. (See Fig.16)

- Clean the piston and check the ball and contacting surface of the piston for defacement or pit mark.  
 - Insert the greasing piston into the cylinder to inspect for a sliding fitness or defacement of both the parts.

4) To re-assemble, clean each part with washing oil and assemble them in reverse order of disassembling method.

- Take care of setting the intake valve parts in order, as shown on Fig.16. Also, firmly connect all the parts each other with new washers (If possible).

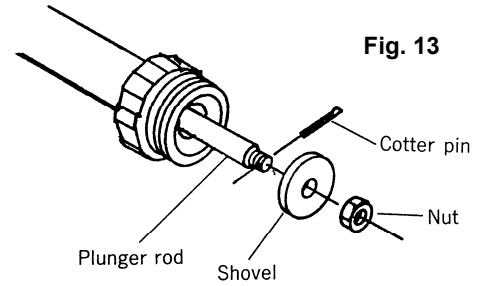

**Fig. 13**

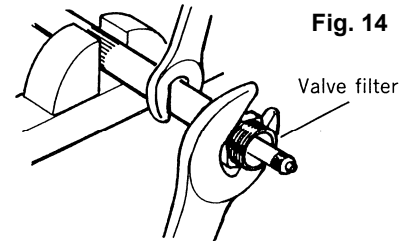

**Fig. 14**

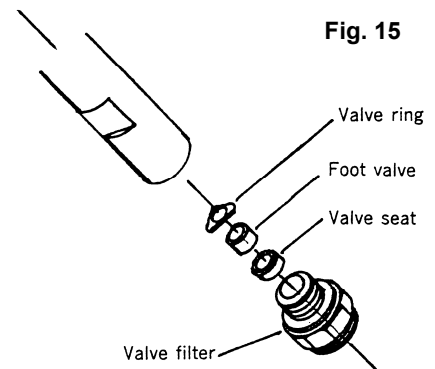

**Fig. 15**

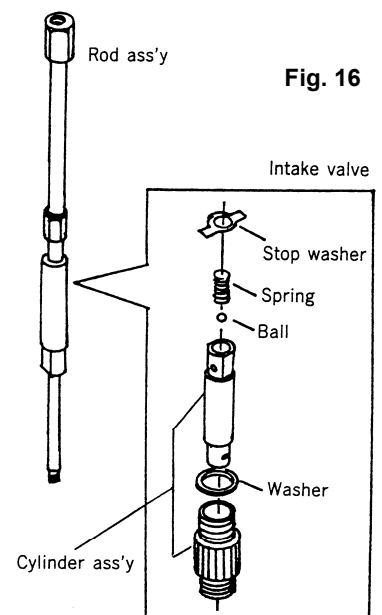

**Fig. 16**

## 6. Parts Disassembly Drawing and Parts List

### 6.1 SKR-66 (880877)

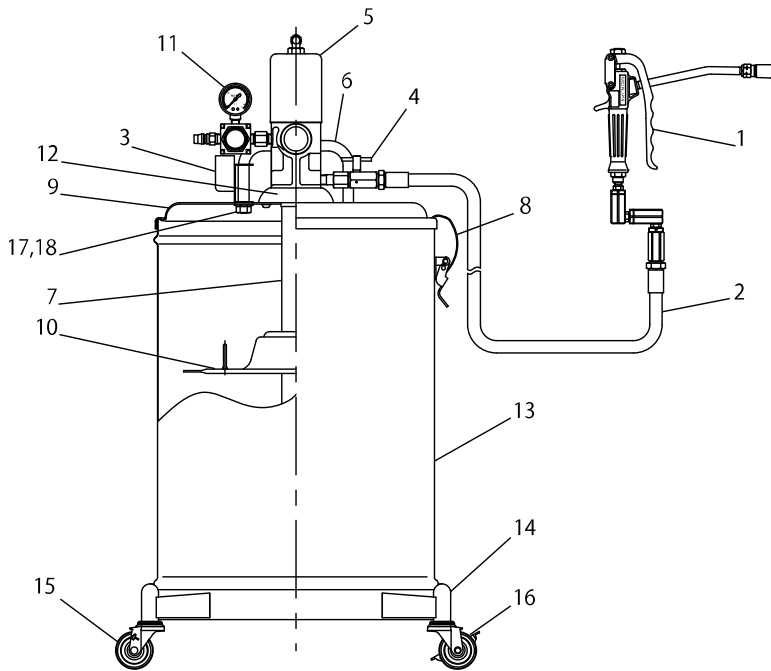

No.	Parts No.	Descriptions	Q'ty
1	851985	Grease gun	1
2	695034	Hi-pressure hose	1
3	830138	Gun holder	1
4	800766	Check valve	1
5	852764	Pump Ass'y	1
6	705841	Handle	1
7	709600	Out tube	1
8	830112	Clasp	3
9	707227	Lid	1
10	802161	Follower plate	1
11	801241	Air regulator	1
12	709000	Pump holder	1
13	830964	Cabinet	1
14	830746	Base frame	1
15	680136	Caster	2
16	681767	Caster(with brake)	2
17	682276	Nut	2
18	631013	Washer	2

### 6.2 Grease Gun (851985)

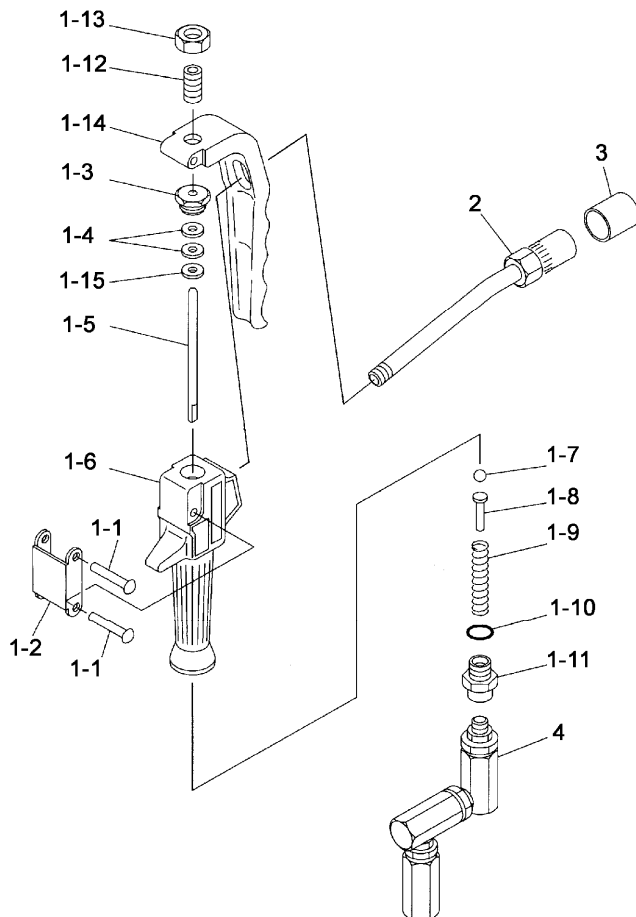

No.	Parts No.	Descriptions	Q'ty
1-1	683201	Rivet	2
1-2	711351	Link	1
1-3	711444	Retaining nut	1
1-4	772160	Paking	2
1-5	711357	Rod	1
1-6	711352	Body	1
1-7	630314	Ball	1
1-8	711445	Spring retainer	1
1-9	711446	Spring	1
1-10	640011	O ring	1
1-11	710971	Union	1
1-12	711750	Bolt	1
1-13	627641	Nut	1
1-14	711354	Lever	1
1-15	713638	Washer	1
2	804911	Nozzle	1
3	685728	Cap	1
4	802910	Swivel joint Ass'y	1

■ No. 1-1, 1-2, 1-6 and No. 1-14 are undissolution.

### 6.3 Air Motor (802630) (For grease pump)

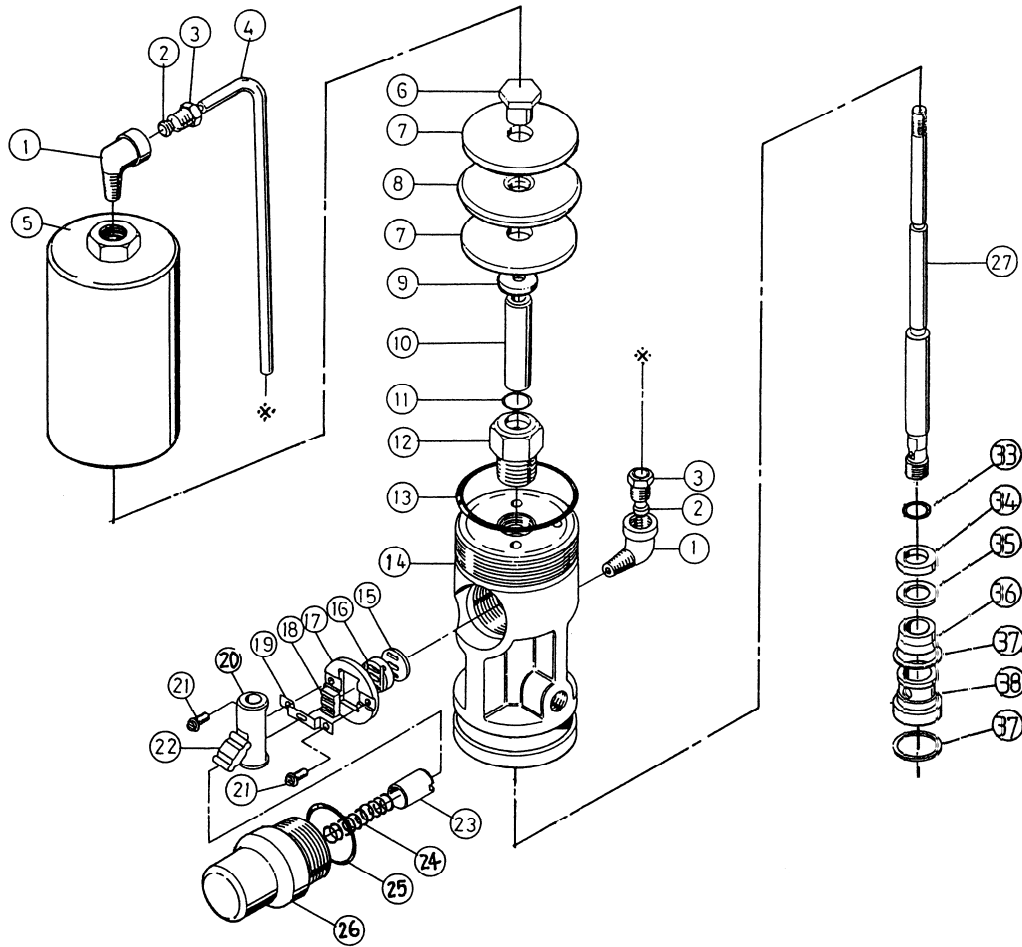

No.	Parts No.	Descriptions	Q'ty	No.	Parts No.	Descriptions	Q'ty
1	701768	Elbow	2	18	701823	Valve slide	1
2	701765	Tube sleeve	2	19	701816	Valve supporter	1
3	701766	Tube gland	2	20	705659	Trip shoe	1
4	708523	Air passage tube	1	21	681768	Screw(w/spring)	2
5	708311	Air cylinder bonnet	1	22	705661	Trip shoe guide	1
6	701811	Cap nut	1	23	704893	Spring holder	1
7	701815	plate	2	24	701825	Spring	1
8	770180	Piston packing	1	25	682976	O-ring	1
9	701810	Washer	1	26	710672	Spring cover	1
10	706067	Spindle bush	1	27	706068	Piston rod	1
11	640012	O-ring	1	33	683629	O-ring	1
12	706066	Gland housing	1	34	710949	Washer	1
13	770182	O-ring	1	35	771405	Back-up ring	1
14	710950	Air motor body	1	36	771418	U-packing	1
15	770181	Valve seat gasket	1	37	702582	Washer	2
16	701822	Valve seat	1	38	711384	Collar	1
17	590085	Valve guide plate	1				

#### <NOTE>

- If disassembly is required, ask the dealer to disassemble the air motor.
- As for the specialist of the dissolution, refer to the instruction manual.  
(Separately APP 006U : Instruction for Grease Pump )

## 6.4 Lower Pump

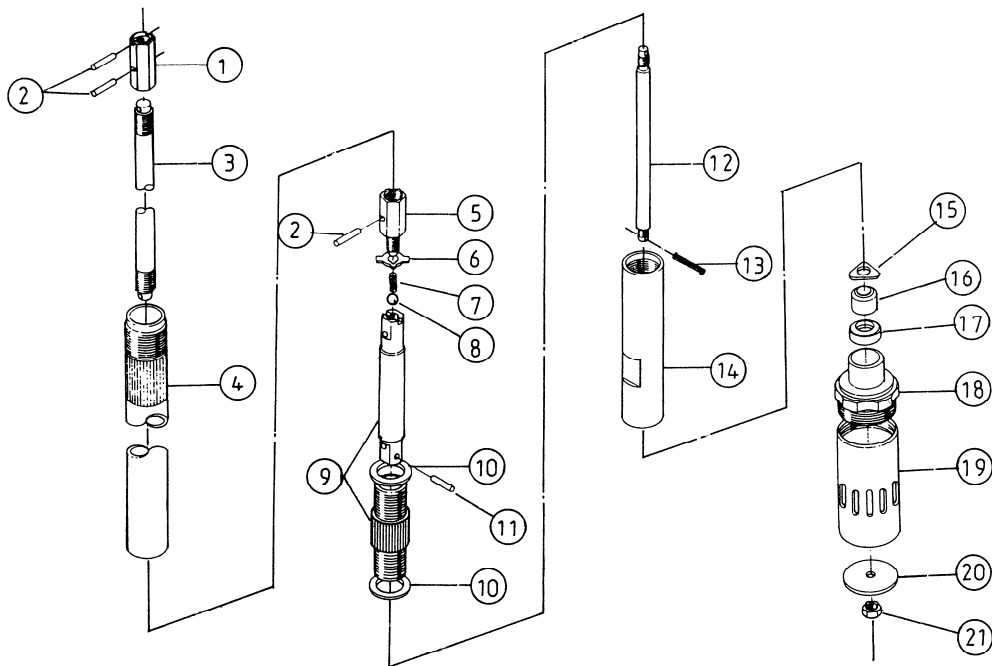

No.	Parts No.	Descriptions	Q'ty
1	706091	Union	1
2	702971	Pin	3
3	709598	Rod	1
4	709599	Suction tube	1
5	702975	Union	1
6	702974	Stop washer	1
7	702976	Spring	1
8	630313	Ball	1
9	803355	Cylinder Ass'y	1
10	702977	Washer	2
11	632754	Spring pin	1
12	706399	Plunger rod	1
13	632019	Cotter pin	1
14	706072	Foot tube	1
15	702980	Valve ring	1
16	771404	Foot valve	1
17	702982	Valve seat	1
18	830407	Valve filter	1
19	702983	Tube	1
20	702984	Shovel	1
21	627010	Nut	1

## 7. Specifications

### ■ Engineering Data

TYPE		SKR - 66
ITEM No.		880877
PUMP RATIO (NOMINAL)		55 × 1
MATERIAL CONNECTION	DISCHARGE PORT	High pressure grease gun
AIR CONNECTION	SUPPLY PORT	Coupler plug, PS-20PM
OPERATING AIR PRESSURE		0.2 - 0.7 MPa
MAXIMUM OPERATING NOISE	A-WEIGHTED SOUND PRESSURE LEVEL *1	86 dB
	A-WEIGHTED SOUND POWER LEVEL *2	96 dB
AMB. TEMP. RANGE	TEMP. AMBIENT	0 - 60 °C
	TEMP. MATERIAL	0 - 80 °C
WEIGHT		17.6 kg
ACCESSORIES		695034 High-pressure hose 1/4×2.5 m 851985 Grease gun 801241 Air regulator with coupler 802161 Follower plate

\*1 Measurement method of A-weighted sound pressure level is based on ISO 1996.

\*2 Measurement method of A-weighted sound power level is based on ISO 3744.

### ■ Performance Curve (only the pump)

#### <NOTE>

The continuous pump operation should be avoided if the desired delivery is in the range shaded in the figure below.

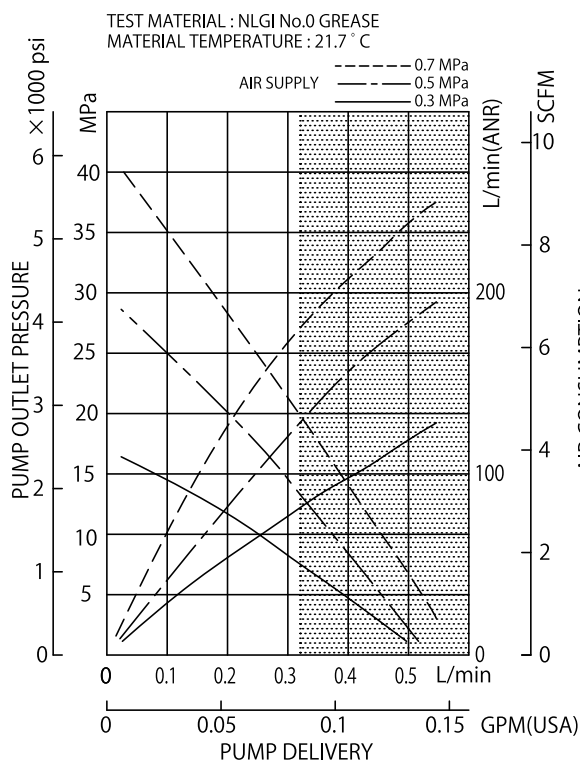

### ■ Dimensions

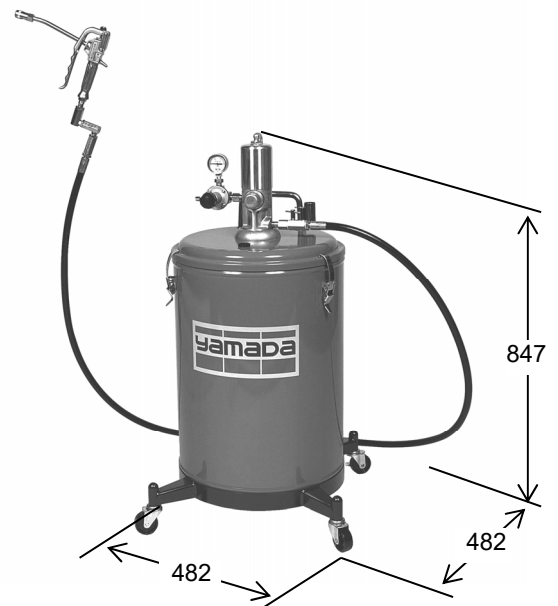

## 8. Limited Warranty

If an abnormality occurs during normal operation in accordance with the operating instructions and other operating cautions within the warranty period (12 months after date of purchase) that can be attributed to a manufacturing defect, the defective parts of this product will be serviced or the product will be replaced free of charge. However, this warranty will not cover compensation for incidental damage or any malfunction listed below.

### 1. Warranty period

This warranty will be valid for a period of 12 months after the date of purchase.

### 2. Warranty

If, during the warranty period, any of the material of the genuine parts of this product or the workmanship of this product is found defective, and is so verified by our company, the servicing cost will be fully born by our company.

### 3. Exclusion

Even during the warranty period, this warranty does not cover the following.

- 1) Malfunction arising from use of parts other than manufacturer-specified genuine parts
- 2) Malfunction arising from misuse or operating errors, or lack of storage or maintenance care
- 3) Malfunction arising from use with a fluid that may cause corrosion, inflation or dissolution of the component parts of the product
- 4) Irregularity arising from repair made by other than by our firm, our regional office, dealer or authorized service personnel
- 5) Malfunction arising from modification of the product by other than authorized service personnel
- 6) Wear and tear of parts that must be regularly replaced in the course of normal operation, such as packings, O-rings and hose.
- 7) Malfunction and/or damage due to use with incorrect voltage.
- 8) Malfunction and/or damage due to transportation, moving or drop page of the product after purchase
- 9) Malfunction and/or damage due to fire, earthquake, flood or other force majeure
- 10) Malfunction arising from use of compressed air that contains impurities or excessive moisture, or use of gases or fluids other than the specified compressed air
- 11) Malfunction arising from use of excessively abrasive material or of inadequate grease.

Furthermore, this warranty does not cover the rubber parts, or other parts used in this product and its accessories, which are subject to wear in normal operation.

- hoses
- packings
- cords

### 4. Parts

Parts for this product will be kept available for 5 years after discontinuation of production. Once 5 years have elapsed after close of production, availability of parts for this product cannot be guaranteed.



## **YAMADA EUROPE B.V.**

Aquamarijnstraat 50,7554 NS Hengelo (O),The Netherlands

PHONE : +31-(0)74-242-2032

FAX : +31-(0)74-242-1055

E-mail : sales@yamada.nl

Web : www.yamada-europe.com

Manufactured by

## **YAMADA CORPORATION**

**INTERNATIONAL DEPARTMENT**

1-1-3, Minami-Magome,Ota ku, Tokyo, 143-8504, Japan

PHONE : +81-(0)3-3777-0241

FAX : +81-(0)3-3777-0584

E-mail : intl@yamadacorp.co.jp

Web : www.yamadacorp.co.jp