

MAINTENANCE MANUAL

YAMADA AIR-OPERATED DOUBLE DIAPHRAGM PUMP

DP-20F/P

DP-25F/P

DP-38F/P

WARNING

-  - For safety's sake, be sure to read this maintenance manual thoroughly before starting maintenance for this product. After reading the manual, keep it in an easy-to-access place so that the user may refer to it whenever necessary.

This maintenance manual describes the items required for maintenance of the Yamada DP-F/P series Diaphragm Pumps.

This document is based on the products that are manufactured in July 2022. NOTE that its contents are subject to change as a result of specification changes to be made in future.

- Warnings and Cautions

To use this product safely, be sure to observe the contents of the following description. In this manual, warnings and cautions are indicated by using symbols. These symbols are intended to prevent death or serious injury that may be caused to the operator or those who are around the product and damage that may be caused to the articles that are around the product, as well as to use the product safely and correctly. Each symbol is indicated and has a meaning as shown below. Read the description with a good understanding of its contents.

 **WARNING:** This indicates the existence of potential hazard which, if not avoided, will result in death or serious injury.

 **CAUTION:** This indicates the existence of potential hazard which, if not avoided, may result in bodily injury or in physical damage.

To indicate the contents of danger and damage, the following symbols are used together with the above indications.





This symbol indicates an act that is prohibited (prohibition). The concrete contents of prohibition are indicated by the side of the indication.



This symbol indicates the contents that must be observed. The concrete contents of observance are indicated by the side of the indication.

WARNING

-  - Before starting the maintenance work, shut off the supply air and clean the pump. If air pressure or residual liquid remains in the pump, damage or explosion may be caused to the product or serious injury or death may be caused if it sticks on the eyes or skin or inhaled or swallowed. (For cleaning the pump, refer to Chapter 6 of the Operation Manual.)
-  - When replacing parts, be sure to use the genuine parts or equivalents. Using parts other than these parts may result in a fault. (Refer to Parts List the separate sheets.)

CAUTION



-  - When it is indicated that dedicated tools should be used, be sure to use these dedicated tools, otherwise the pump may be damaged.
-  - Check the weight of the pump by referring to "10.1 Main Specifications" in the operation manual and take extreme care when lifting it.

Table of Contents

·Warnings and Cautions	
·Table of Contents	
1.Principles of operation	1
2.Maintenance and Tools	
2.1 Maintenance	1
2.2 General tools	1
2.3 Special tools	1
2.4 Others	1
3.Balls, Flat valves and Valve seats	
3.1 Removal	2
3.2 Inspection	
■ Ball valve types	3
■ Flat valve types	3
3.3 Installation	3
4.Diaphragm and Center rod	
4.1 Removal	4
4.2 Inspection	5
4.3 Installation	5
5.Pilot valve Assembly, Valve Seats	
5.1 Removal	6
5.2 Inspection	6
5.3 Installation	7
6.C Spool valve Assembly and Sleeve Assembly	
6.1 Removal	7
6.2 Inspection	9
6.3 Installation	10
7.Retightening of Tie rods	10
8.Instructions for applying lubrication	
8.1 Applying Lubricant to the Packing	11
8.2 Applying Lubricant to the Center Rod	11
8.3 Assembly	11

1. Principles of operation

There are two diaphragms fixed to the center rod, one at each end. When compressed air is supplied to air chamber b (right side, see Fig.1.1), the center rod moves to the right, the material in material chamber B is pushed out, and at the same time material is sucked into material chamber A.

When the center rod is moved full-stroke to the right, the air switch valve is switched, compressed air is sent to air chamber a (left side, see Fig.1.2), and the center rod moves to the left. The material in material chamber A is pushed out, and at the same time material is sucked into material chamber B.

Through repetition of this operation, material is repeatedly taken in and discharged out.

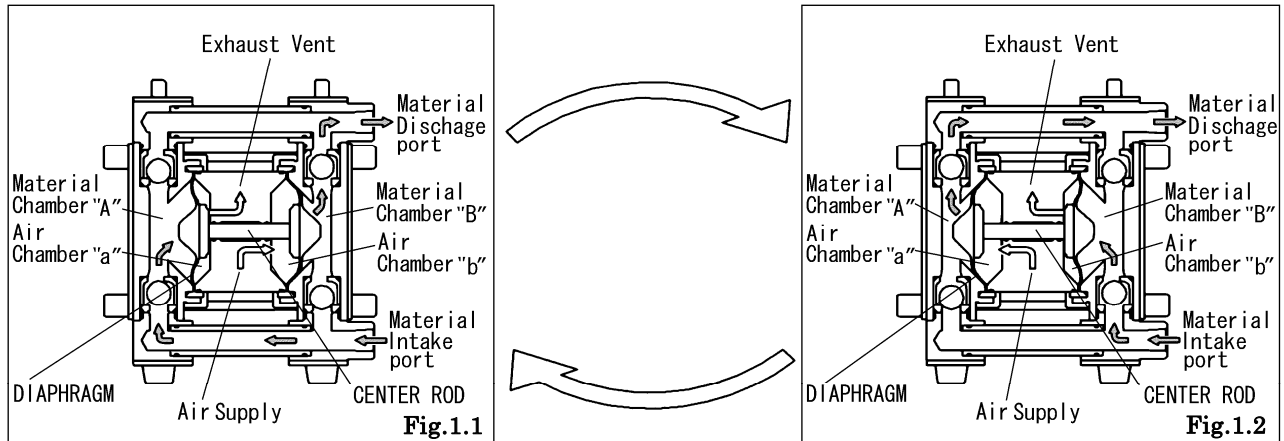

2. Maintenance and Tools

2.1 Maintenance

It is recommended that the pump should be regularly inspected, as this kind of diaphragm pump can be used in many different circumstances such as pressures, temperatures, viscosities, or corrosiveness.

It's very useful for your future reference to keep records of the pump conditions for every inspection.

The regular inspection includes the air valve, diaphragms, balls, valve seats, or O-rings.

When it comes to diaphragms, in particular, both of the diaphragms should be replaced at one time, as they tend to be worn out or have some cracks on the surfaces. Please refer to 'usage range' in each section regarding the frequency of the replacement of the other spare parts.

2.2 General tools

- Socket wrenches 10 mm, 13 mm, 17 mm
- Open-end wrenches 13 mm, 17 mm
- Plyer
- Snap ring pliers
- Flat head screwdriver

2.3 Special tools (sold separately)

- Pilot valve remover
For pilot valve, cap and valve seat
Part No. 712606
- Sleeve remover
For sleeve
Part No. 713148

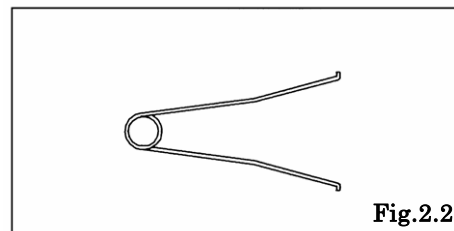
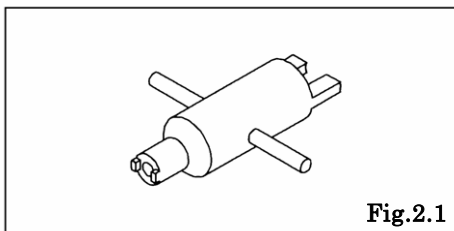

2.4 Others

- Assembly lubricant (oil) Fomblin® Y25 or equivalent
- Assembly lubricant (grease) Fomblin® GR AR555 or equivalent

3. Balls, Flat valves and Valve seats

3.1 Removal

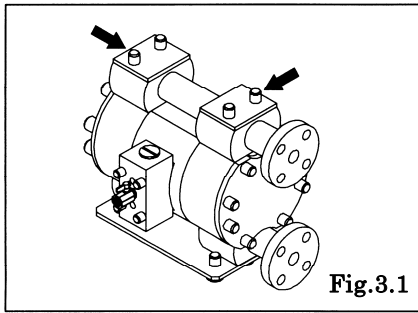

- Remove the 8 caps (4 on the top and 4 on the bottom) from both sides of the vertical tie rods. [Fig.3.1]

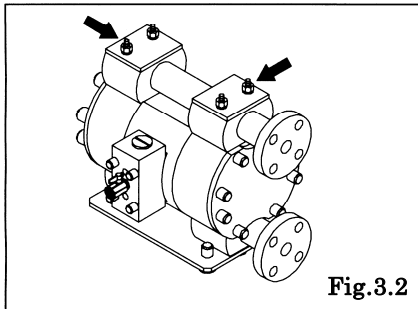

- Unscrew the 4 retainer nuts from the upper side of the vertical tie rods. Then, remove the reinforcement plates, O rings, and out manifolds. [Fig.3.2]

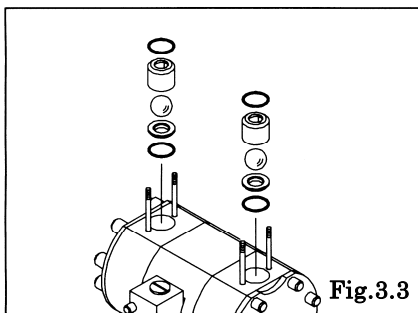

- Remove the O rings, valve stoppers, valve guides, balls or flat valves, and valve seats. [Fig.3.3]

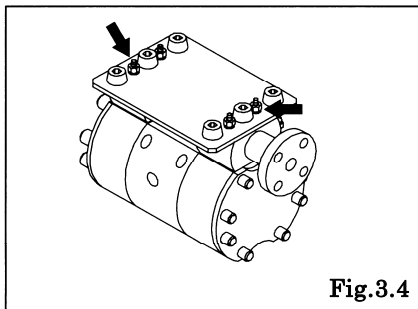

- Turn over the body assembly. [Fig.3.4]
- Pull out the four vertical tie rods and remove the base and in-manifold. [Fig.3.4]

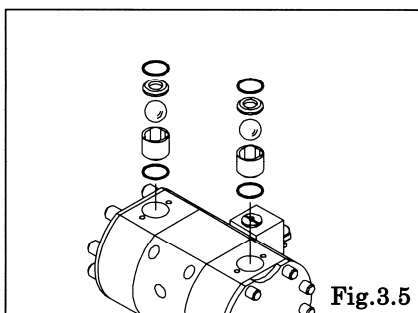

- Remove the O rings, valve seats, balls or flat valves, valve guides and valve stoppers. [Fig.3.5]

3.2 Inspection

■ Ball valve type

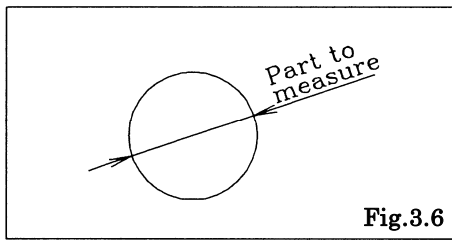

- Ball [Fig.3.6]
Measure the diameter, and if it is not within the permissible range, replace the ball.

Permissible range of ball diameter

DP-20F/P	SØ 24.3 - SØ 27.8 mm
DP-25F/P, DP-38F/P	SØ 31.5 - SØ 36.0 mm

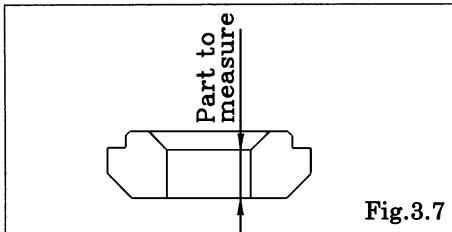

- Valve seat [Fig.3.7]
Measure the dimension shown at left, and if it is not within the permissible range, replace the valve seat.

Permissible range of valve seat dimension

DP-20F/P	2.8 - 7.0 mm
DP-25F/P, DP-38F/P	3.2 - 7.5 mm

■ Flat valve type

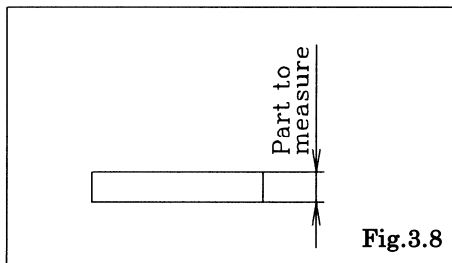

- Flat valve [Fig.3.8]
Measure the dimension shown at left, and if it is not within the permissible range, replace the flat valve. If the flat valve is worn out or cracked, replace it, too.

Permissible range of flat valve dimension

5.6 - 7.2 mm

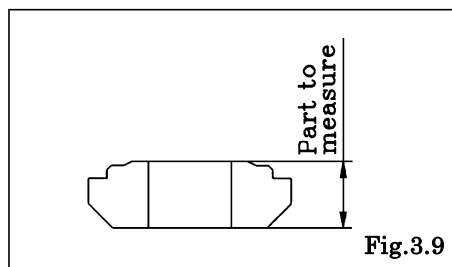

- Valve seat [Fig.3.9]
Measure the dimension shown at left, and if it is not within the permissible range, replace the valve seat.

Permissible range of valve seat dimension

9.6 - 12.2 mm

3.3 Installation

For installation, see [Exploded View] on the separate sheet and install in the reverse order of disassembly.

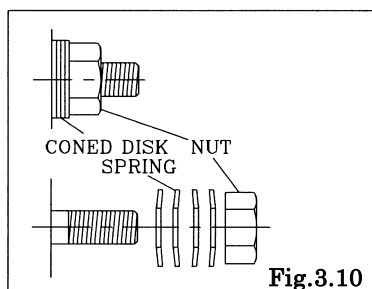

Tightening torque for vertical tie rods

DP-20F/P	5 N·m
DP-25F/P	7 N·m
DP-38F/P	15 N·m

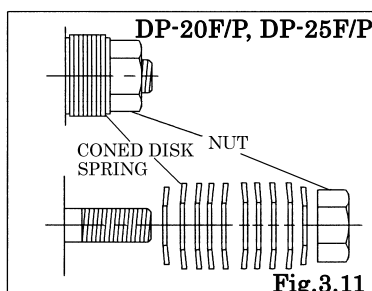

<NOTE>

- Make sure the sealing surface is not dirty or damaged.
- Replace the PTFE O rings regardless of its condition.
- Make sure that the directions of each coned disk spring are correct. [Fig.3.10, Fig.3.11]
- Retighten the tie rods before starting the pump.
(See “7. Retightening of tie rods”)

4. Diaphragm and Center rod

4.1 Removal

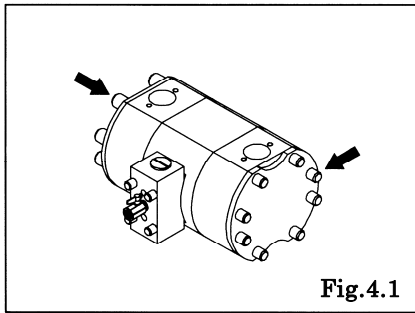

- Remove the balls or flat valves, valve seats, valve guides, valve stoppers, etc. (see “3.1 Removal”)
- Remove the 12 caps (16 caps for DP-38F/P) from both sides of horizontal tie rods. [Fig.4.1]

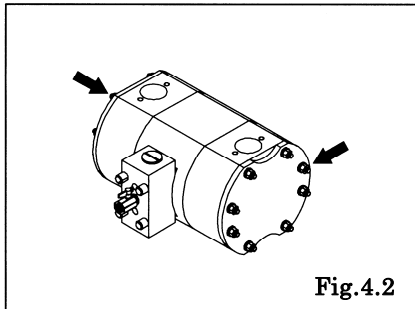

- Unscrew the 12 retainer nuts (16 nuts for DP-38F/P) on the horizontal tie rods. Then, remove the reinforcement plates, O rings and out chambers. [Fig.4.2]

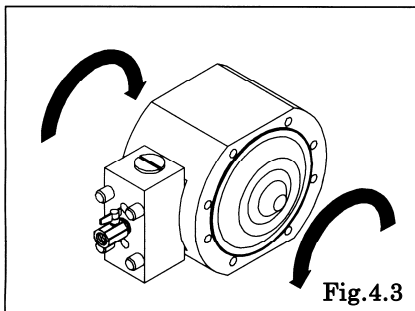

- Turn the diaphragms in the directions of the arrows to separate the diaphragm on one side. [Fig.4.3]

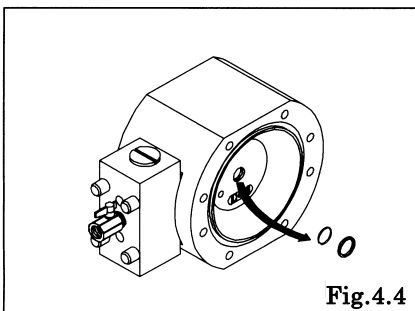

- Remove the packings and wipers from both sides of the body. [Fig.4.4]

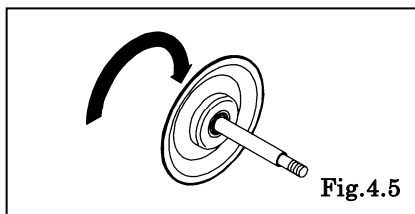

- Hold the middle of the center rod by hand or clamp it with a vise. Then, turn the diaphragm to separate from the rod. [Fig.4.5]

< NOTE >

- When using a vise, be very careful not to damage the center rod.

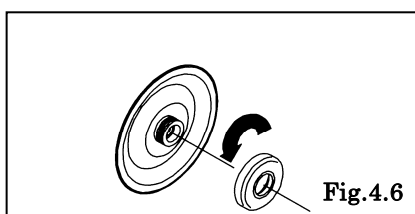

- Hold the diaphragm and turn the bushing in the direction of the arrow to separate it from the diaphragm. [Fig.4.6]

4.2 Inspection

- Diaphragm
If the diaphragm is worn out or damaged, replace it.
Never replace just one diaphragm.

Frequency of inspecting the diaphragms
(Transferring water at room temperature)

6,000,000 cycles

*The standard in our facility is 'Air supply pressure 0.5 MPa with no discharge pressure.

*It's recommended to conduct an inspection, if 3 months have passed since you start using the pump, or if the number of cycles reaches the above.

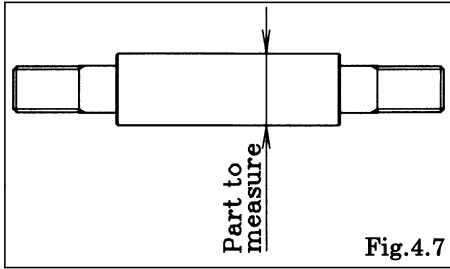

Fig.4.7

- Center rod [Fig.4.7]
Measure the diameter, and if it is not within the permissible range, replace the center rod.

Permissible range of center rod diameter

DP-20F/P	Ø 17.92 - Ø 17.98 mm
DP-25F/P	Ø 23.92 - Ø 23.98 mm
DP-38F/P	Ø 29.87 - Ø 29.95 mm

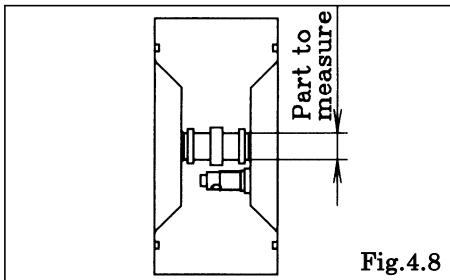

Fig.4.8

- Body [Fig.4.8]
Measure the inside diameter, and if it is not within the permissible range, replace the body.

Permissible range of body dimension

DP-20F/P	Ø 18.03 - Ø 18.11 mm
DP-25F/P	Ø 24.03 - Ø 24.11 mm
DP-38F/P	Ø 30.03 - Ø 30.10 mm

- Packing, Wiper
Replace the packing and wiper if they are worn out or damaged.
- Bushing
Replace the bushing if the thread is damaged.

4.3 Installation

For installation, see [Exploded View] on the separate sheet and install in the reverse order of disassembly.

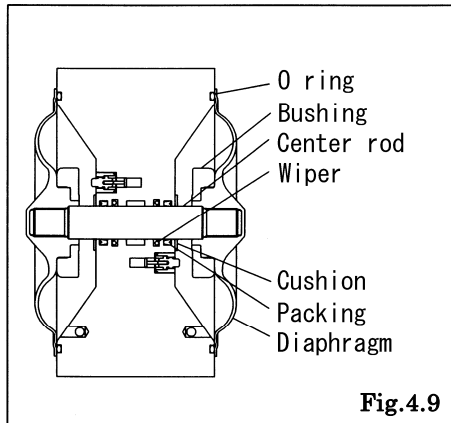

Fig.4.9

- Soak the wipers in lubricant oil and fit them in the pump body.
- Apply grease to the packings and fit them in the pump body.
(see "8. Instructions for applying lubrication")
- Attach the bushings to the diaphragm securely.
- Turn the diaphragm assembly with hands until it stops to complete the body assembly.

Tightening torque for horizontal tie rods

DP-20F/P	9 N·m
DP-25F/P	10 N·m
DP-38F/P	15 N·m

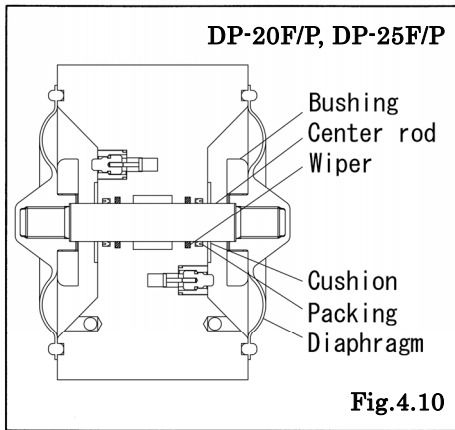

Fig.4.10

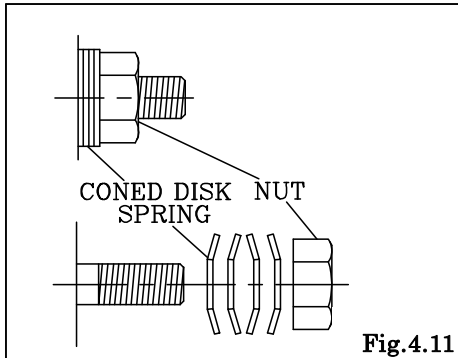

Fig.4.11

<NOTE>

- Make sure the sealing surface is not dirty or damaged.
- Tighten the nuts evenly and alternately in a diagonal sequence to the specified torque.
- Make sure that the directions of each coned disk spring are correct. [Fig.4.11]
- Attach the pilot valve and bushing securely. (See “5.3 Installation”)
- Retighten the tie rods before starting the pump. (See “7. Retightening of tie rods”)

5. Pilot Valves Assembly, Valve Seats

5.1 Removal

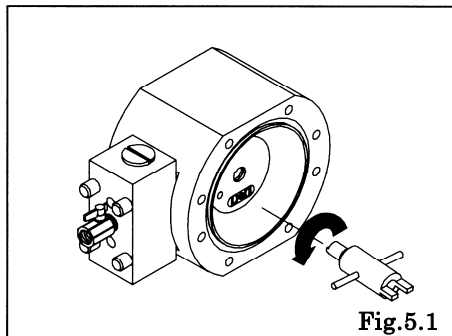

Fig.5.1

- Remove the diaphragms and center rod. (See “4.1 Removal”).
- Remove the valve seats from the body assembly using the pilot valve remover (special tool: Part No. 712606).
- Remove the O rings, pilot valve assembly, and springs. [Fig.5.1]

5.2 Inspection

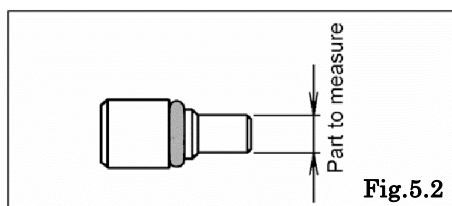

Fig.5.2

- Pilot valve assembly [Fig.5.2]
Measure the diameter, and if it is not within the permissible range, replace the pilot valve assembly with a new one.

Permissible range of diameter of pilot valve

DP-20F/P	Ø 4.8 - Ø 5.0 mm
DP-25F/P, DP-38F/P	Ø 6.7 - Ø 7.2 mm

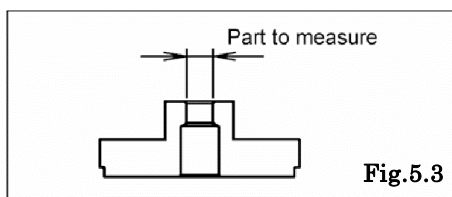

Fig.5.3

- Valve seat [Fig.5.3]
Measure the inside diameter, and if it is not within the permissible range, replace the valve seat with a new one.

Permissible range of valve seat diameter

DP-20F/P	Ø 7.0 - Ø 7.2 mm
DP-25F/P, DP-38F/P	Ø 10.0 - Ø 10.2 mm

- Spring
Always replace the springs at the time of maintenance.
- O ring
Replace the O ring if it is worn out or damaged.

5.3 Installation

For installation, see [Exploded View] on the separate sheet and install in the reverse order of disassembly.

<NOTE>

- The O ring on the valve seat is easily separated. Ensure that the O ring is fitted on the valve seat when attaching the valve seat to the body.
- Insert the seat stopper into the body by turning it until it reaches the body surface.
- Make sure the sealing surface is not dirty or damaged.
- Use the pilot valve remover (special tool: Part No. 712606).
- Retighten the tie rods before starting the pump.
(See “7. Retightening of tie rods”)

6. C Spool valve Assembly

6.1 Removal

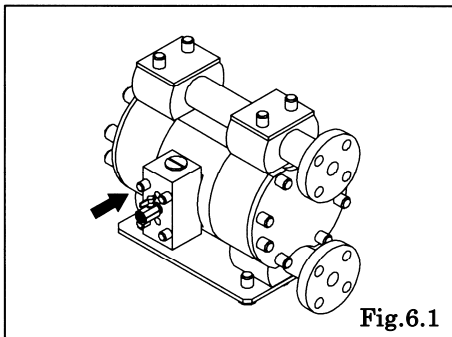

- Remove the 4 cap from the stud bolts. [Fig.6.1]

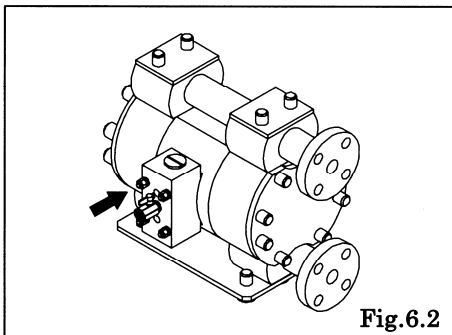

- Unscrew the 4 retainer nuts from the valve body assembly to remove the valve body. [Fig.6.2]

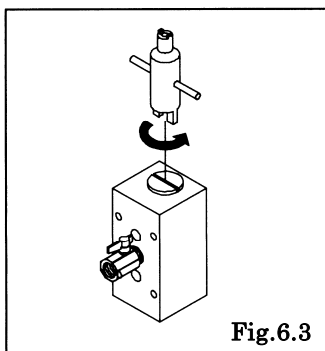

- Remove the caps on both sides of the valve body using the pilot valve remover (special tool: Part No. 712606). [Fig.6.3]

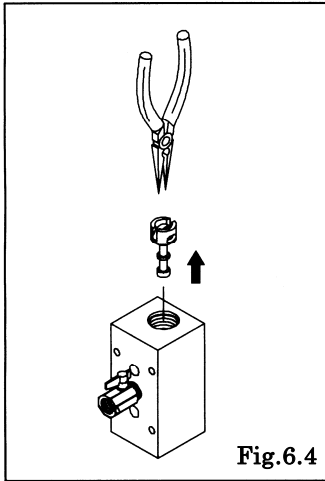

Fig.6.4

- Use pliers to pull out the C spool valve assembly. [Fig.6.4]

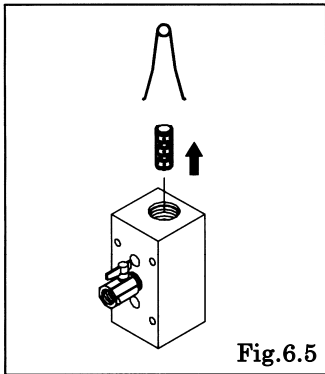

Fig.6.5

- Remove the sleeve from the valve body using the sleeve remover (special tool: Part No. 713148). [Fig.6.5]

<NOTE>

- Be careful not to damage or crack the sliding surface when pulling out the C spool valve assembly and sleeve.

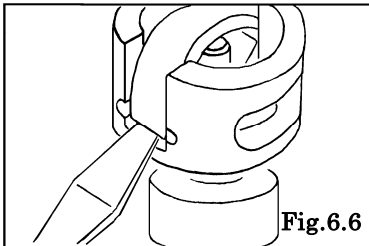

Fig.6.6

- C spring removal
Insert a flathead screwdriver under the end of the C spring and lift up on the end outward to release the C spring. [Fig.6.6 and 6.7]

<NOTE>

- Once the C spring is removed, the arm will be released.

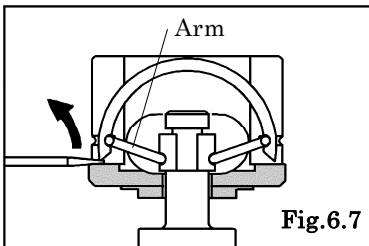

Fig.6.7

- With snap ring pliers, push to remove the interlocking bushing while widening its groove. [Fig.6.8 and 6.9]

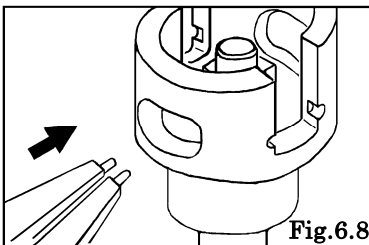

Fig.6.8

<NOTE>

- Do not exert excessive force on the spool.
- Do not widen the groove of the bushing unnecessarily.
- Once the interlocking bushing is removed, the spring bearing and cushion will be removed, too.

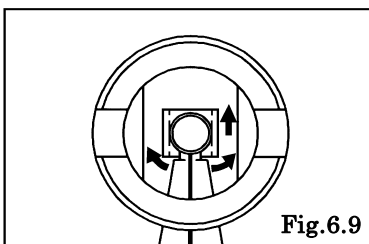

Fig.6.9

6.2 Inspection

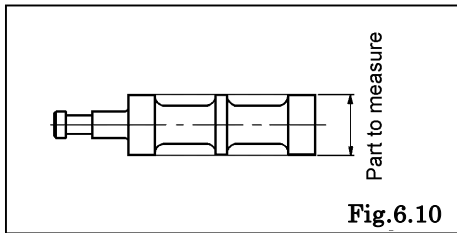

Fig.6.10

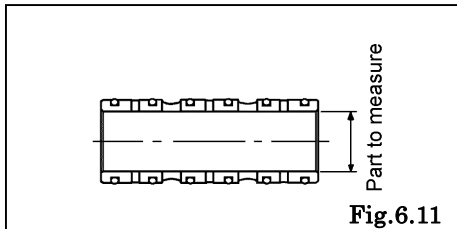

Fig.6.11

- Spool [Fig.6.10]
Measure the outside diameter, and if it is not within the permissible range, replace the spool.

Permissible range of spool diameter

Ø 15.73 - Ø 15.80 mm

- Sleeve [Fig.6.11]
Measure the inside diameter, and if it is not within the permissible range, replace the sleeve. If the sleeve is cracked or damaged, replace it, too.

Permissible range of sleeve diameter

Ø 15.80 - Ø 15.86 mm

- O rings
Replace the O ring if it is worn out or cracked.

<NOTE>

- Be sure to replace the spool and sleeve together as a complete set.
(Set No : DP-20F/P 804395 DP-25,38F/P 804396)

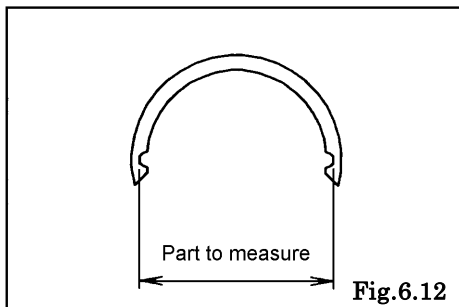

Fig.6.12

- C spring [Fig.6.12]
Measure the dimension shown on the left figure, and if it is not within the permissible range, replace the C spring.

Permissible range of C spring dimension

DP-20F/P	25.9 - 26.5 mm
DP-25F/P, DP-38F/P	29.4 - 30.0 mm

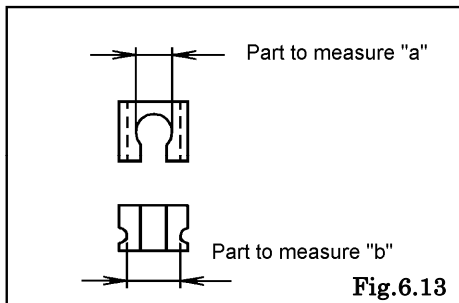

Fig.6.13

- Interlocking bush [Fig.6.13]
Measure the dimensions shown on the left figure, and if it is not within the permissible range, replace the interlocking bush with a new one.

Usable range of Interlocking bush dimension

Part to measure "a"	DP-20F/P	4.8 - 5.0 mm
	DP-25F/P, DP-38F/P	5.5 - 5.7 mm
Part to measure "b"	DP-20F/P	6.8 - 7.1 mm
	DP-25F/P, DP-38F/P	7.3 - 7.6 mm

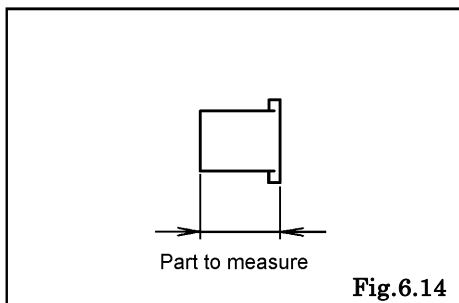

Fig.6.14

- Arm [Fig.6.14]
Measure the dimension shown on the left figure, and if it is not within the permissible range, replace the arm.

Permissible range of arm dimension

DP-20F/P	10.5 - 10.9 mm
DP-25F/P, DP-38F/P	12.2 - 12.6 mm

- Spring bearing
Replace the spring bearing if it is worn out or damaged.
- Cushion
Replace the cushion if it is worn out or damaged.

6.3 Installation

For installation, see [Exploded View] on the separate sheet and install in the reverse order of disassembly.

Tightening torque for Valve body installation bolts

DP-20F/P	2 N·m
DP-25F/P, DP-38F/P	7 N·m

<NOTE>

- Make sure the sealing surface is not dirty or damaged.
- Securely insert the caps into the body by turning them until they reach the body surface.
- Retighten the tie rods before starting the pump.
(See “7. Retightening of tie rods”)

7. Retightening of Tie rods

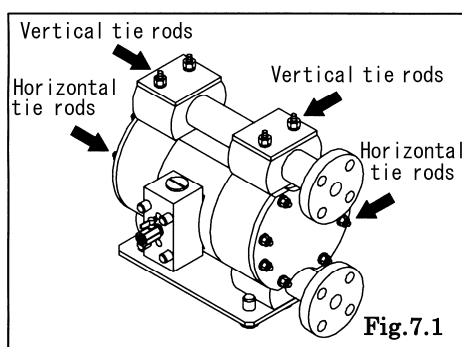

- Due to the nature of resin, the dimensions of the pump may vary according to operating temperature or across the ages. Check each sealed part for leaks periodically and retighten the parts indicated by arrows.
- Retighten the tie rods in the following situations:
 - ① immediately before using the pump,
 - ② at the time of quarterly inspections (or biannual if the room temperature, such as in a clean room, is maintained within plus or minus 5°C of the ambient temperature),
 - ③ when restarting the pump at low temperature which has stopped running because ambient temperature or liquid temperature became too high, and
 - ④ if a leak is found on a daily inspection.

Retightening torque of the tie rods

	Horizontal tie rods	Vertical tie rods
DP-20F/P	6 N·m	4 N·m
DP-25F/P	8 N·m	8 N·m
DP-38F/P	13 N·m	13 N·m

<NOTE>

- Retighten the nuts evenly and alternately in a diagonal sequence to the specified torque.
- Be sure to retighten the horizontal tie rods **FIRST**, and then the vertical tie rods. [Fig.7.1]
(Fig.7.1 shows the DP-38F/P.)

8. Instructions for applying lubrication

8.1 Applying Lubricant to the Packing

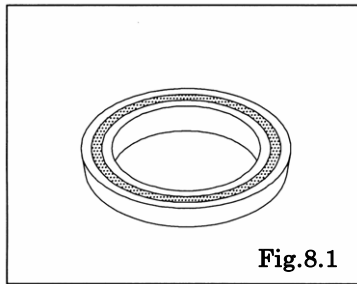

- Apply plenty of grease to a v-groove of the packing. [Fig.8.1]
- <NOTE>
- Be careful not to produce air bubbles when applying grease.

8.2 Applying Lubricant to the Center Rod

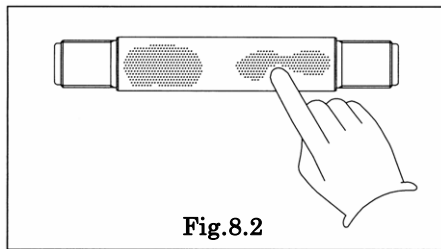

- Apply a small amount of grease the sliding surface of the center rod. [Fig.8.2]

8.3 Assembly

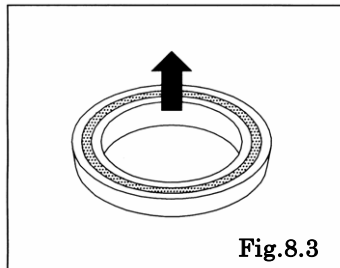

- Attach the v packing to the body, facing the v-groove toward the air chamber. [Fig.8.3]
- <NOTE>
- If the v packing is attached in the wrong direction, an operation failure may occur.

YAMADA CORPORATION

INTERNATIONAL DEPARTMENT

1-1-3, Minami-Magome, Ota ku, Tokyo, 143-8504, Japan

PHONE : +81-(0)3-3777-0241

FAX : +81-(0)3-3777-0584

E-mail : intl@yamadacorp.co.jp

Web : www.yamadacorp.co.jp

YAMADA (THAILAND) CO., LTD

41/79 Moo 6, Bangcha-long, Bangplee, Sumutprakarn 10540, Thailand

PHONE : +66-(0)2-130-0990

FAX : +66-(0)2-130-0993

E-mail : sales@yamada-th.com