



Doc. No.	NDP 289M-07
----------	-------------

MAINTENANCE MANUAL

YAMADA AIR-OPERATED DOUBLE DIAPHRAGM PUMP

NDP-50FAN

WARNING



- For your own safety, be sure to read these procedures carefully before performing maintenance on this product. After reading this document, be sure to keep it handy for future reference.

This maintenance manual covers what you should know about maintenance of the Yamada NDP-50FAN Diaphragm Pumps.

This edition is based on the standards for the July 2022 production run. Remember, the specifications are always subject to change; therefore, some of the information in this edition may not apply to new specifications.

Warnings and Cautions

For safe use of this product, be sure to note the following: In this document, warnings and cautions are indicated by symbols. These symbols are for those who will operate this product and for those who will be nearby, for safe operation and for prevention of personal injury and property damage. The following warning and caution symbols have the meanings described below. Be sure to remember their meanings.



WARNING : If you ignore the warning described and operate the product in an improper manner, there is danger of serious bodily or property damage.



CAUTION : If you ignore the caution described and operate the product in an improper manner, there is danger of personal injury or property damage.

Furthermore, to indicate the type of danger and damage, the following symbols are also used along with those mentioned above:



This symbol indicates a DON'T, and will be accompanied by an explanation on something you must not do.



This symbol indicates a DO, and will be accompanied by instructions on something you must do in a certain situation.

WARNING



- Before starting maintenance work, cut off the feed air and clean the pump. If air pressure or residue remain in the pump, there is danger of explosion, or possible poisoning resulting in serious injury or death if chemicals adhere to the skin or are accidentally swallowed. (For details on cleaning the pump, refer to Chapter 6 of the Operation Manual.)



- When replacing parts, be sure to use the recommended genuine parts or Equivalents. Use of other parts may cause a malfunction of the product. (Refer to Parts List the separate sheets.)

CAUTION



- When it is instructed that special tools must be used, be sure to use the specified tools. Otherwise, the pump may be damaged.



- Refer to “10.1 Specifications” in the Operation Manual. Also, remember that the pump is heavy, and extreme care must be taken when lifting it.

Table of Contents

·Warnings and Cautions	
·Table of Contents	
1.Principles of operation	1
2.Maintenance and Tools	
2.1 Maintenance	1
2.2 General tools	1
2.3 Special tools	1
2.4 Misc.	1
3.Ordering Replacement parts	1
4.Valve assembly (Flap valve, Valve seats)	
4.1 Removal	2
4.2 Inspection	3
4.3 Installation	3
5.Diaphragm and Center rod	
5.1 Removal	4
5.2 Inspection	5
5.3 Installation	5
6.Throat bearing and Pilot valve assembly	
6.1 Removal	6
6.2 Inspection	6
6.3 Installation	6
7.C Spool valve assembly	
7.1 Removal	7
7.2 Inspection	8
7.3 Installation	8
8.Retightening of Tie rods	9

1.Principles of operation

There are two diaphragms fixed to the center rod, one at each end. When compressed air is supplied to air chamber b (right side, see Fig. 1.1), the center rod moves to the right, the material in material chamber B is pushed out, and at the same time material is sucked into material chamber A.

When the center rod is moved full-stroke to the right, the air switch valve is switched, compressed air is sent to air chamber a (left side, see Fig.1.2), and the center rod moves to the left. The material in material chamber A is pushed out, and at the same time material is sucked into material chamber B. Through repetition of this operation, material is repeatedly taken in and discharged out.

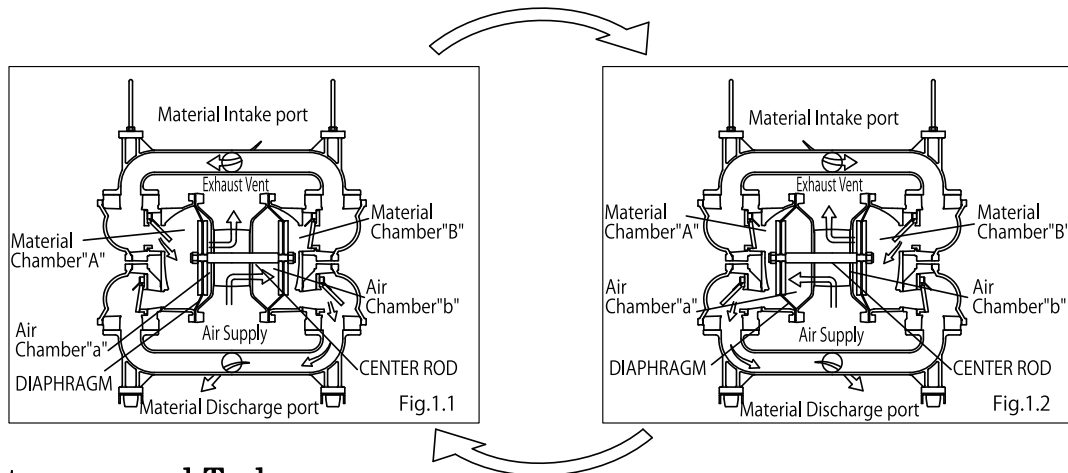

2.Maintenance and Tools

2.1 Maintenance

It is recommended that the pump should be regularly inspected, as this kind of diaphragm pump can be used in many different circumstances such as pressures, temperatures, viscosities, or corrosiveness. It's very useful for your future reference to keep records of the pump conditions for every inspection. The regular inspection includes the air valve, diaphragms, balls, valve seats, or O-rings. When it comes to diaphragms, in particular, both of the diaphragms should be replaced at one time, as they tend to be worn out or have some cracks on the surfaces. Please refer to 'usage range' in each section regarding the frequency of the replacement of the other spare parts.

2.2 General tools

- Socket wrenches 10 mm, 13 mm, 17 mm, 19 mm, 24 mm
- Hexagonal box wrenches 5 mm, 6 mm, 8 mm
- Small crowbars 2
- Open-end wrenches 10 mm, 17 mm, 19 mm, 24 mm
- Plastic hammer

2.3 Special tools

- Sleeve remover (sold separately)
Purpose: For removing sleeve

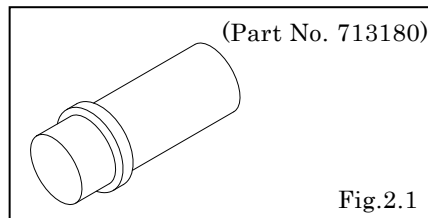

2.4 Misc.

- Assembly oil Turbine oil none addition class 1 (equivalent to ISO VG32 grade)
- Nuts M 16 X 1.5
- Grease Urea grease grade (NLGI) No. 2

3.Ordering Replacement parts

For accurate and speedy shipment of parts, be sure to order the right parts for your model to distributor. Indicate the part numbers, descriptions, and quantities.

4. Valve assembly (Flap valve, Valve seats)

4.1 Removal

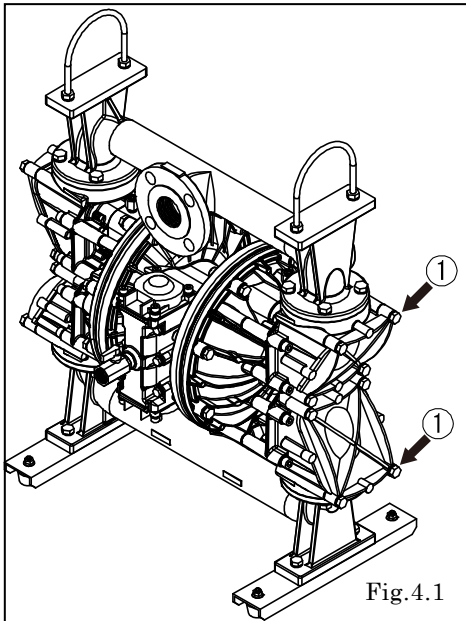

- Remove 4 bolts ① from the cover, and remove the cover. [Fig.4.1]

<NOTE>

There is parallel only at valve case(out) (bottom side).

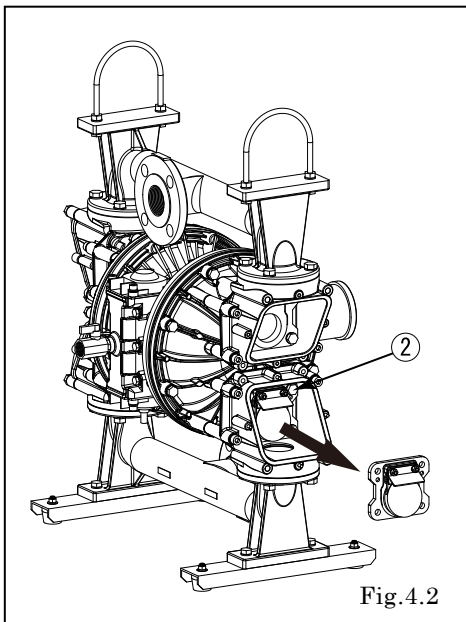

- Remove 4 bolts ② from the valve assembly, and remove the valve assembly. [Fig.4.2]

4.2 Inspection

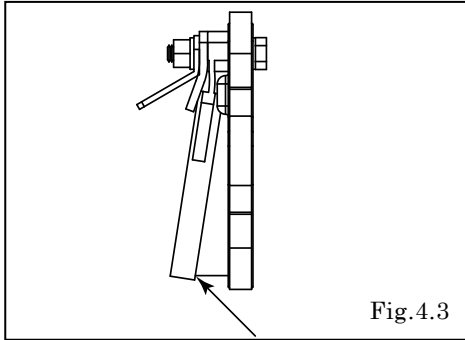

Fig.4.3

- If there is a gap between the flap valve and valve seat, replace it. [Fig.4.3]

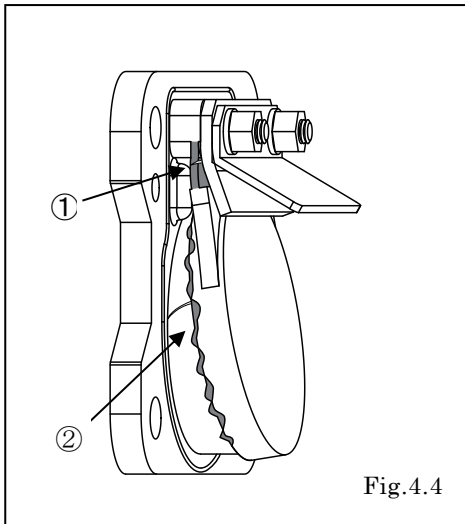

Fig.4.4

- If ① or ② are broken or cracked, replace it.

The recommended inspection timing of the flap valves and the valve seats is as per table below. Please note that it is different from the pump inspection timing shown on page 1.

(When used with clean water at room temperature)

Operation hours (h)	250
---------------------	-----

4.3 Installation

For installation, see [Exploded View] on the separate sheet and install in the reverse order of disassembly.

Tightening torque for Valve assembly installation bolts

30 N · m

Tightening torque for Cover assembly installation bolts

30 N · m

5.Diaphragm and Center rod

5.1 Removal

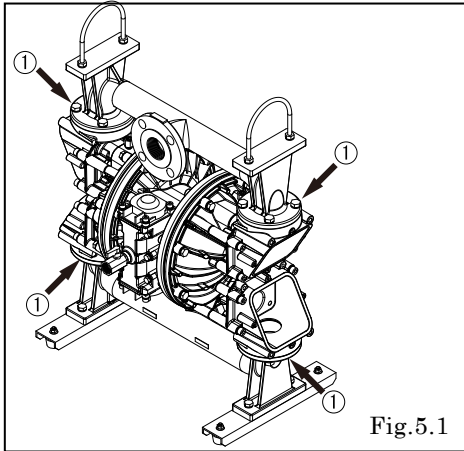

- Remove the cover, valve assembly, etc. (see “4.1 Removal”)
- Remove the silencer.
- Replace 16 bolts ① from the manifold, and remove the manifold and the O ring. [Fig.5.1]

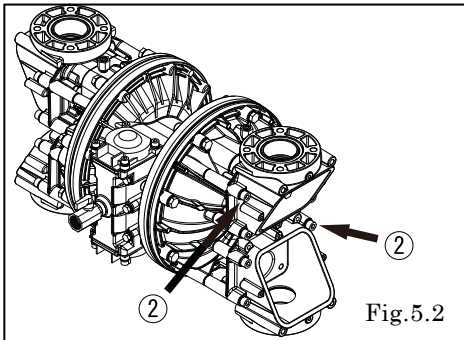

- Remove each 4 bolts ② from the valve case(in) and the valve case(out), and remove the valve case(in), the valve case(out), the O ring and the gasket. [Fig.5.2]

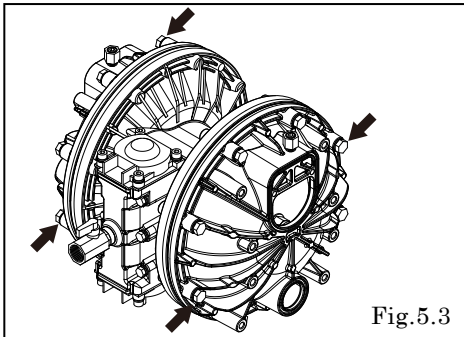

- Remove the 16 retainer bolts from the out chamber, and remove the out chamber. [Fig.5.3]

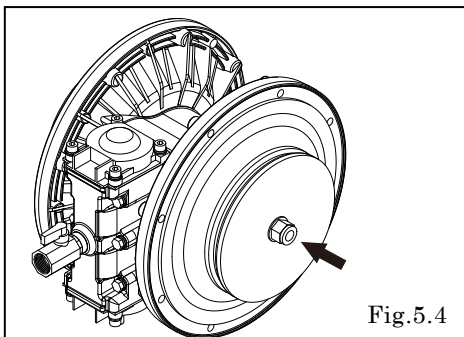

- Remove the nuts on both sides of the center rod. [Fig.5.4]
- Remove the center disk and center rod from the opposite side of the main body.

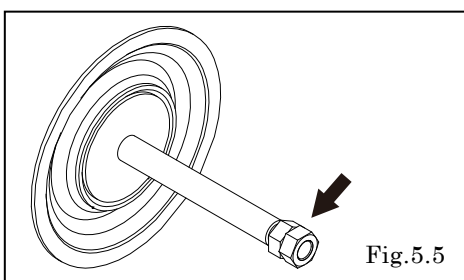

- Fix a double nut to one end of the center rod and take the diaphragm and center disk off the opposite end. [Fig.5.5]

5.2 Inspection

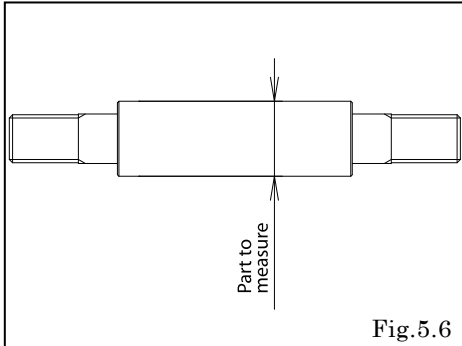

▪ Diaphragm

If the diaphragm is worn out or damaged, replace it.
Never replace just one diaphragm.

Frequency of inspecting the diaphragms
(Transferring water at room temperature)

10,000,000 cycle

*The standard in our facility is 'Air supply pressure 0.5 MPa with no discharge pressure.

*It's recommended to conduct an inspection, if 3 months have passed since you start using the pump, or if the number of cycles reaches the above.

▪ Center rod [Fig.5.6]

Measure the diameter, and if it is outside the usable range, replace the rod.

Usable range of center rod

$\varnothing 24.93 - \varnothing 25.00$ mm

5.3 Installation

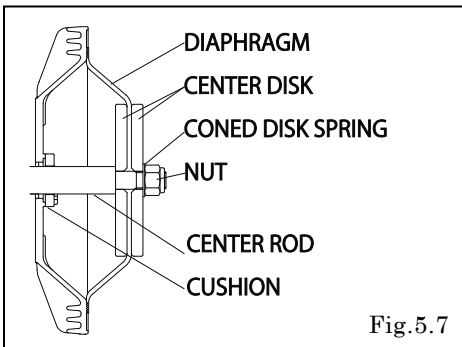

- Apply assembly grease to center rod, and insert it into the main body.
- Insert the cushion. [Fig.5.7]
- Keep the marking "OUTSIDE" to liquid end for diaphragms.

Tightening torque for center rod

60 N·m

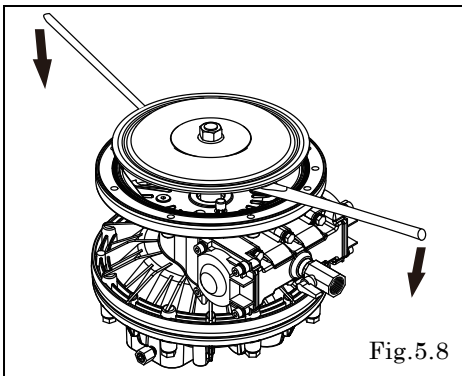

- Draw the center disk to one side and install the out chamber. [Fig.5.9].
- Grip the inside center disk using crowbars and draw it to the opposite side, then turn the diaphragm over. [Fig.5.8, Fig.5.9]
- And install the out chamber.
- Install the valve case(in) and the valve case(out). Tighten the bolts temporarily.
- Place the pump on a flat surface and level mounting surface of the manifold, and tighten the bolts with required torque listed below.

Tightening torque for out chamber

35 N·m

Tightening torque for valve case in out

30 N·m

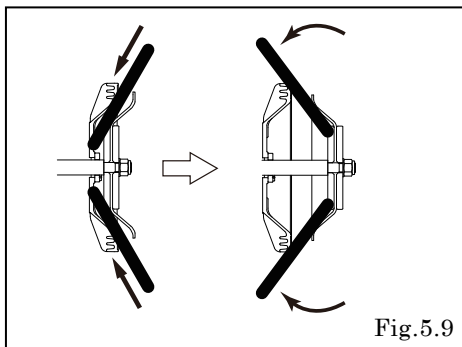

<NOTE>

- Make sure there is no dust on the seal surface in order to prevent seal damaged.
- Be careful not to damage the R portion of the air chamber using a crowbar, etc.
- Tighten the bolts that balance should be equal from both Side on diagonal line with even torque.
- Tighten the bolts gradually in a diagonal sequence with even torque. [Fig.5.10].

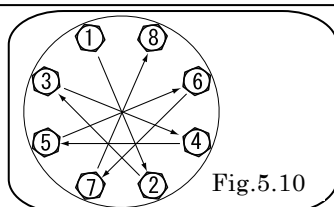

6.Throat bearing and Pilot valve assembly

6.1 Removal

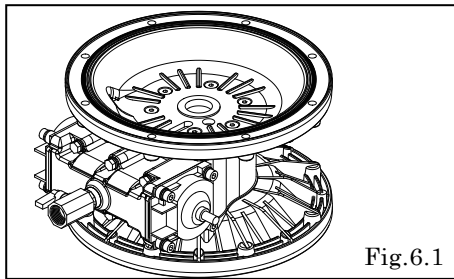

- Remove the diaphragm and center rod. (see “5.1 Removal”).
- Remove the 12 retainer bolts from the air chamber, and remove the air chamber. [Fig.6.1]

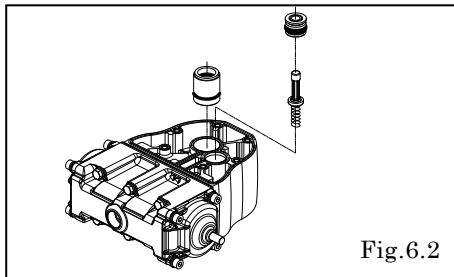

- Draw out the pilot valve and valve seat. [Fig.6.2]
- Draw out the throat bearing. [Fig.6.2]

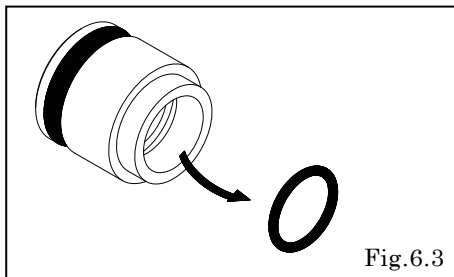

- Remove the packing from the throat bearing. [Fig.6.3]

6.2 Inspection

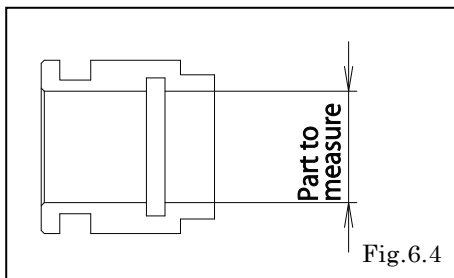

- Throat bearing [Fig.6.4]
Measure the inside diameter, and if it is outside the usable range, replace the throat bearing

Usable range of throat bearing

Ø 25.04 - Ø 25.13mm

- O ring, Packing
If the O ring is worn out or cracked, replace it.
- Pilot valve
If the pilot valve is worn out or cracked, replace it.

6.3 Installation

For installation, see [Exploded View] on the separate sheet and install in the reverse order of disassembly.

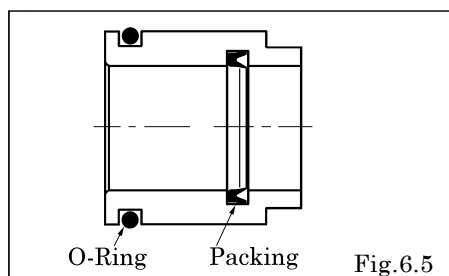

Tightening torque for air chamber retainer bolts

20 N·m

<NOTE>

- Make sure there is no dust on the seal surface and the seal is not damaged.
- Apply grease to packing.

7.C spool valve assembly

7.1 Removal

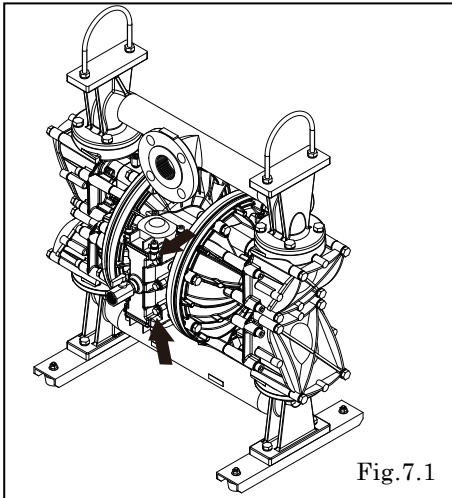

- Remove the 6 retainer bolts from the valve body, and remove the valve body. [Fig. 7.1]

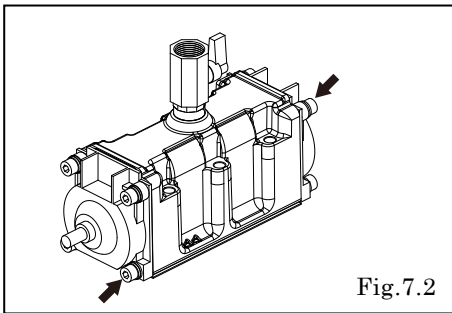

- Remove the 8 cap A and cap B retainer bolts, and remove cap A and cap B. [Fig. 7.2]

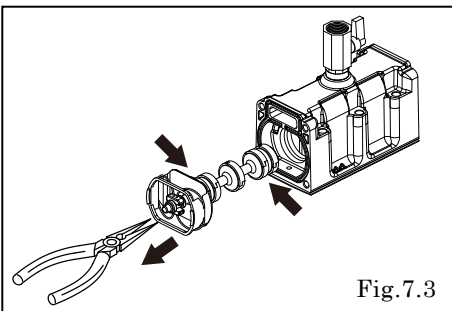

- Draw out the C spool valve assembly, and remove the seal ring from the C spool valve assembly.
- Remove the spring stopper. [Fig. 7.3]

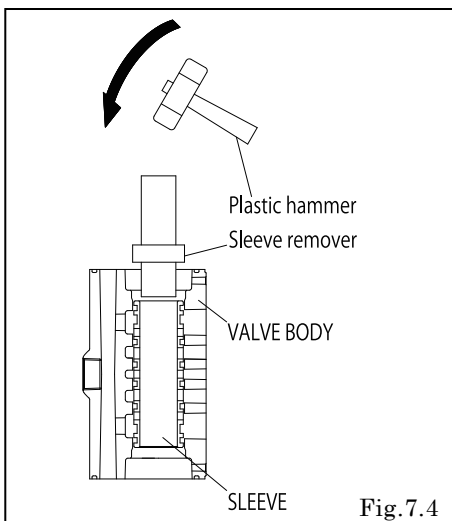

- Remove the sleeve using the sleeve remover (special tool: Part number 713180). [Fig. 7.4]

7.2 Inspection

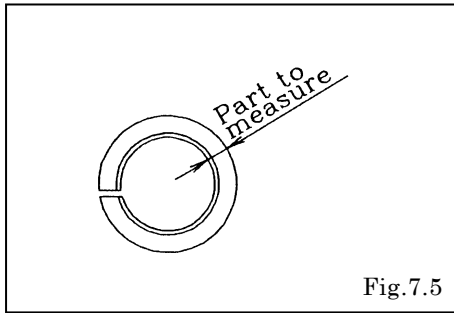

- C Spool Valve Assembly

- Seal ring [Fig.7.5]

- Measure the inside thick diameter, and if it is outside the usable range, replace the C Spool Valve Assembly.

- If the seal ring is worn out or cracked, replace C Spool Valve Assembly.

Usable range of Seal ring

3.77 - 3.85 mm

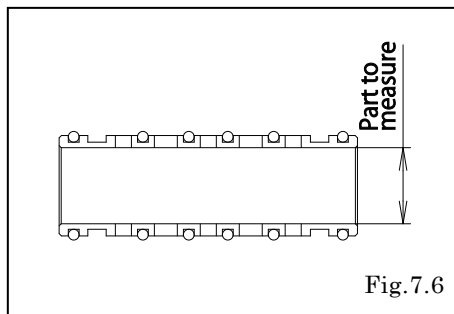

- Sleeve Assembly [Fig.7.6]

- Measure the inside diameter, and if it is outside the usable range, replace the c spool valve assembly.

Usable range of sleeve

Ø 33.15 - Ø 33.35 mm

- O ring

- If the O ring is worn out or cracked, replace it.

<NOTE>

- C Spool Valve Assembly must be replaced as a complete set. Unable to replace individual component.

7.3 Installation

For installation, see [Exploded View] on the separate sheet and install in the reverse order of disassembly.

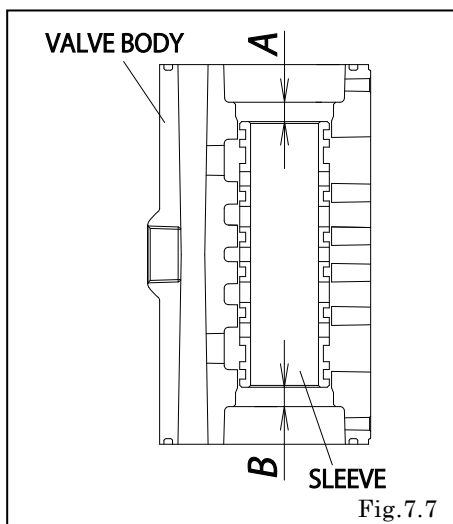

- Install the sleeve using the sleeve remover (special tool:

- Part No. 713180). At this point, apply assembly oil around the sleeve and O ring.

- Install the sleeve at the center of the valve body.

- (A = B)

Tightening torque for installation cap A, cap B

10 N·m

Tightening torque for valve body installation bolts

17 N·m

<NOTE>

- Make sure there is no dust on the seal surface and it is not damaged.

8. Retightening of Tie rods

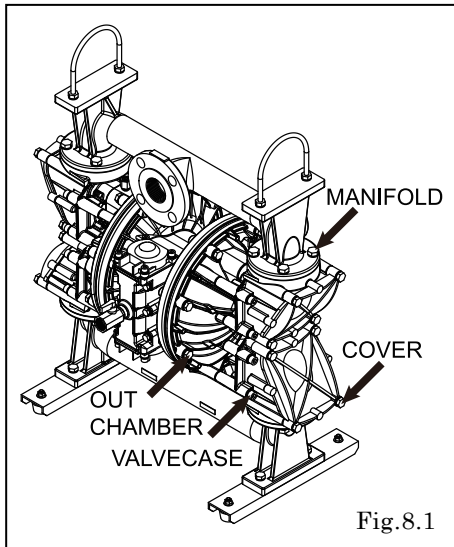

- All bolts should be retorqued:
 - (1) Right before start up.
 - (2) There are any leaks of material on daily inspecting a pump.

Retain bolts for the out chamber	Cover Valve case (in, out)	Retain bolts for the manifold
35 N · m	30 N · m	20 N · m

<NOTE>

- Retighten the Out chamber and then the manifold in this order. [Fig.8.1]
- Tighten the bolts in the order shown. [Fig.8.2]

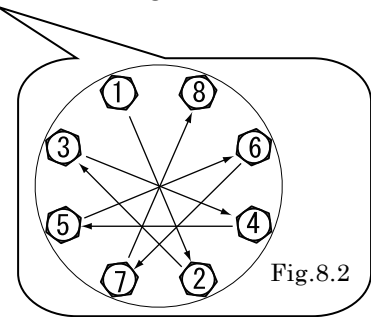

YAMADA CORPORATION

INTERNATIONAL DEPARTMENT

1-1-3, Minami-Magome, Ota ku, Tokyo, 143-8504, Japan

PHONE : +81-(0)3-3777-0241

FAX : +81-(0)3-3777-0584

E-mail : intl@yamadacorp.co.jp

Web : www.yamadacorp.co.jp

YAMADA (THAILAND) CO., LTD

41/79 Moo 6, Bangcha-long, Bangplee, Sumutprakarn 10540, Thailand

PHONE : +66-(0)2-130-0990

FAX : +66-(0)2-130-0993

E-mail : sales@yamada-th.com