

# MAINTENANCE MANUAL

## YAMADA AIR-OPERATED DOUBLE DIAPHRAGM PUMP

NDP-P20

NDP-P25

## WARNING



- For your own safety, be sure to read these procedures carefully before performing maintenance on this product. After reading this document, be sure to keep it handy for future reference.

This maintenance manual covers what you should know about maintenance of the Yamada NDP-P20 series and NDP-P25 series Diaphragm Pumps.

This edition is based on the standards for the July 2022 production run. Remember, the specifications are always subject to change; therefore, some of the information in this edition may not apply to new specifications.

### Warnings and Cautions

For safe use of this product, be sure to note the following: In this document, warnings and cautions are indicated by symbols. These symbols are for those who will operate this product and for those who will be nearby, for safe operation and for prevention of personal injury and property damage. The following warning and caution symbols have the meanings described below. Be sure to remember their meanings.



**WARNING :** If you ignore the warning described and operate the product in an improper manner, there is danger of serious bodily injury or death.



**CAUTION :** If you ignore the caution described and operate the product in an improper manner. There is danger of personal injury or property damage.

Furthermore, to indicate the type of danger and damage, the following symbols are also used along with those mentioned above:



This symbol indicates a DON'T, and will be accompanied by an explanation on something you must not do.



This symbol indicates a DO, and will be accompanied by instructions on something you must do in a certain situation.

## WARNING



- Before starting maintenance work, cut off the feed air and clean the pump. If air pressure or residue remain in the pump, there is danger of explosion, or possible poisoning resulting in serious injury or death if chemicals adhere to the skin or are accidentally swallowed. (For details on cleaning the pump, refer to Chapter 6 of the Operation Manual.)



- When replacing parts, be sure to use the recommended genuine parts or Equivalents. Use of other parts may cause a malfunction of the product. (Refer to Parts list the separate sheets.)

## CAUTION



- When it is instructed that special tools must be used, be sure to use the specified tools. Otherwise, the pump may be damaged.



- Refer to “10.1 Specifications” in the Operation Manual. Also, remember that the pump is heavy, and extreme care must be taken when lifting it.

# Table of Contents

·Warnings and Cautions	
·Table of Contents	
1. Principles of operation	1
2. Maintenance and Tools	
2.1 Maintenance	1
2.2 General tools	1
2.3 Special tools	1
2.4 Misc.	1
3. Ordering Replacement parts	1
4. Balls and Valve seats	
4.1 Removal	2
4.2 Inspection	4
4.3 Installation	4
5. Diaphragm and Center rod	
5.1 Removal	5
5.2 Inspection	6
5.3 Installation	7
6. Throat bearing and Pilot valve Assembly	
6.1 Removal	8
6.2 Inspection	8
6.3 Installation	9
7. C Spool Valve Assembly and Sleeve Assembly	
7.1 Removal	9
7.2 Inspection	10
7.3 Installation	10
8. Retightening of Tie rods	11

## 1. Principles of operation

There are two diaphragms fixed to the center rod, one at each end. When compressed air is supplied to air chamber b (right side, see Fig.1.1), the center rod moves to the right, the material in material chamber B is pushed out, and at the same time material is sucked into material chamber A.

When the center rod is moved full-stroke to the right, the air switch valve is switched, compressed air is sent to air chamber a (left side, see Fig.1.2), and the center rod moves to the left. The material in material chamber A is pushed out, and at the same time material is sucked into material chamber B. Through repetition of this operation, material is repeatedly taken in and discharged out.

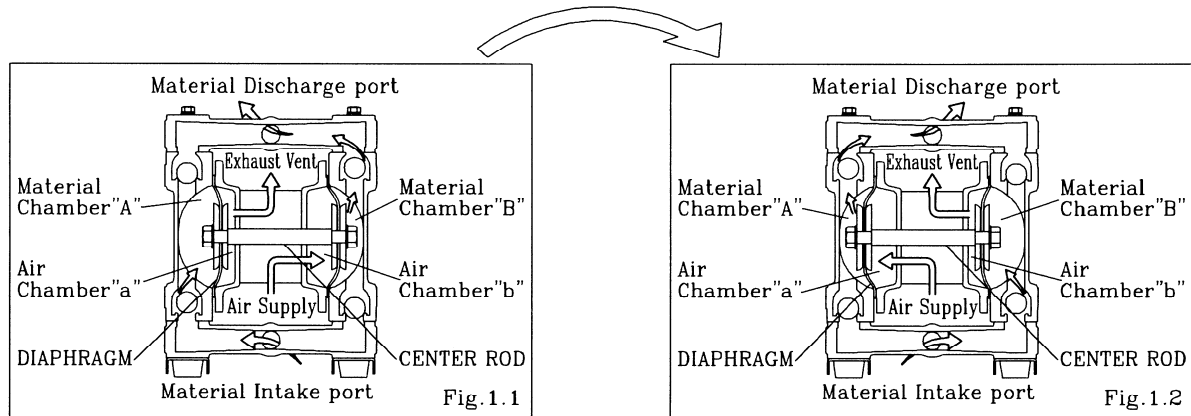

## 2. Maintenance and Tools

### 2.1 Maintenance

It is recommended that the pump should be regularly inspected, as this kind of diaphragm pump can be used in many different circumstances such as pressures, temperatures, viscosities, or corrosiveness. It's very useful for your future reference to keep records of the pump conditions for every inspection.

The regular inspection includes the air valve, diaphragms, balls, valve seats, or O-rings.

When it comes to diaphragms, in particular, both of the diaphragms should be replaced at one time, as they tend to be worn out or have some cracks on the surfaces. Please refer to 'usage range' in each section regarding the frequency of the replacement of the other spare parts.

### 2.2 General tools

- Socket wrenches 10 mm, 12 mm, 13 mm, 17 mm, 22 mm
- Hexagonal box wrenches 5 mm
- Open-end wrenches 12 mm, 13 mm, 22 mm
- Adjustable angle wrenches
- Phillips head screw driver

### 2.3 Special tools

- Accessory tool ( Included )

Purpose: Removing the center disk of BP□ and BV□ types

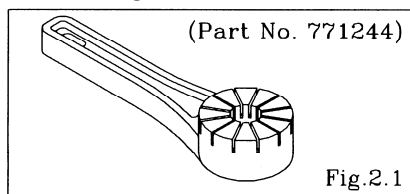

Fig.2.1

- Sleeve remover (sold separately)

Purpose: For removing sleeves

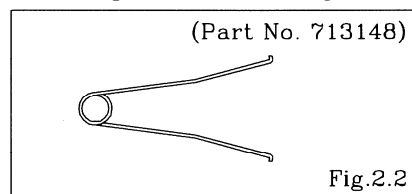

Fig.2.2

### 2.4 Misc.

- Assembly oil Turbine oil none addition class 1( equivalent to ISO VG32 grade)
- Nuts M14×1.5
- Grease Urea grease grade (NLGI) No. 2

## 3. Ordering Replacement parts

For accurate and speedy shipment of parts, be sure to order the right parts for your model to distributor. Indicate the part numbers, descriptions, and quantities.

## 4. Balls and Valve seats

### 4.1 Removal

■ BA□, BS□ types

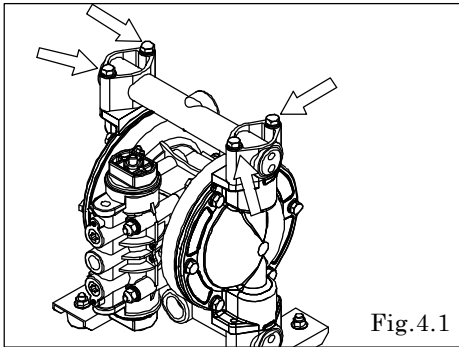

- Remove the 4 retainer bolts from the out manifold, and remove the out manifold. [Fig.4.1]

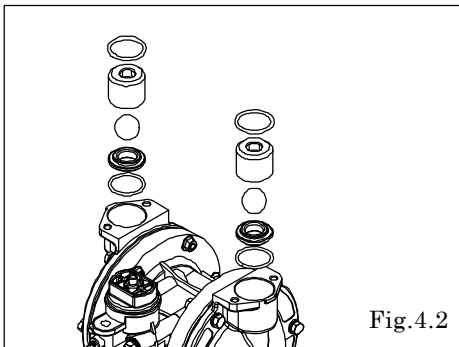

- Remove the O ring, valve stopper, ball and valve seat. [Fig.4.2]

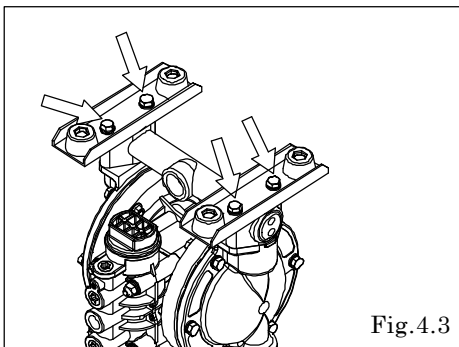

- Remove the 4 retainer bolts from the in manifold, and remove the in manifold and pump bases. [Fig.4.3]

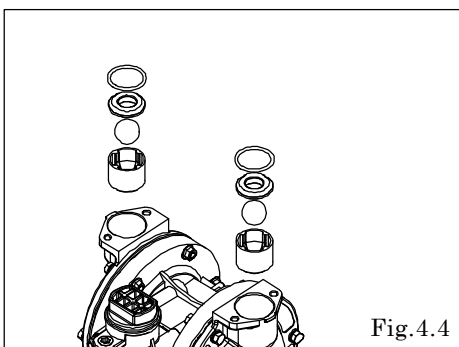

- Remove the O ring, valve seat, ball and valve stopper. [Fig.4.4]

■BP□, BV□ types

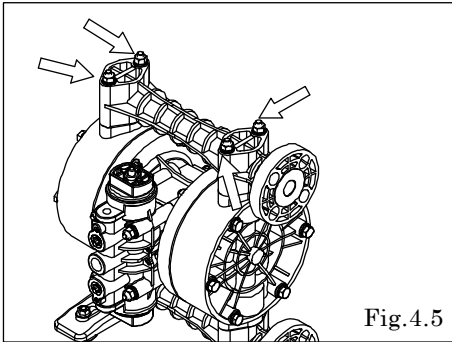

- Remove the 4 retainer nuts from the upper side of tie rods, and remove the out manifold. [Fig.4.5]

<NOTE>

- When the retainer nuts both sides of the tie rod remove, the in manifold removes.

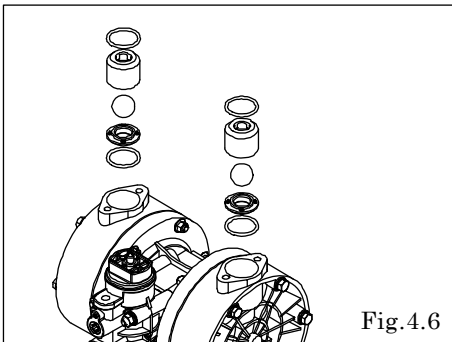

- Remove the O ring, valve stopper, ball and valve seat. [Fig.4.6]

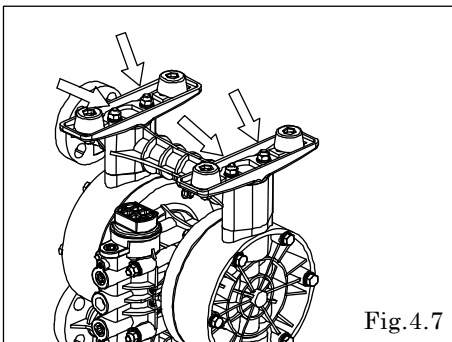

- Pull out the tie rod , and remove the base and in manifold. [Fig.4.7]

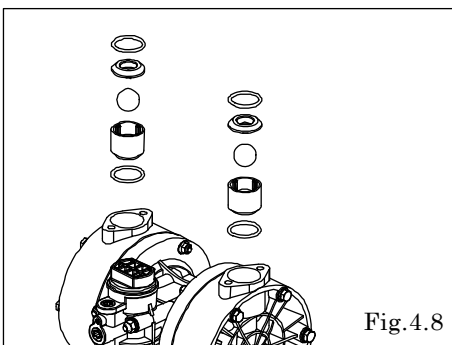

- Remove the O ring, valve seat, ball and valve stopper. [Fig.4.8]

## 4.2 Inspection

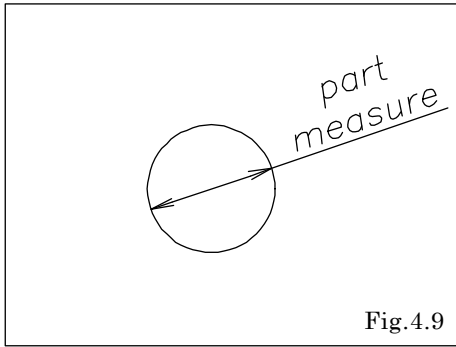

- Ball [Fig.4.9]

Measure the outside diameter, and if it is outside the usable range, replace the ball.

Usable range of Ball

NDP-P20	SØ24.3 - SØ27.8 mm
NDP-P25	SØ31.5 - SØ36.1 mm

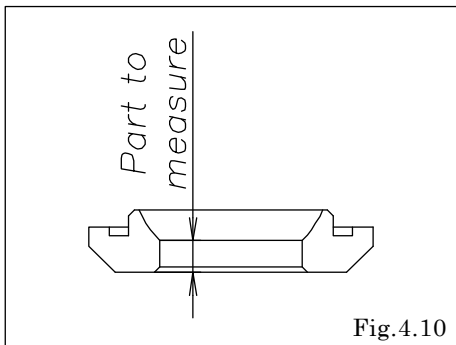

- Valve seat [Fig.4.10]

Measure the dimension shown at left, and if it is outside the usable range, replace the valve seat.

Usable range of Valve seat

	BA□, BS□	BP□, BV□
NDP-P20	3.4 - 8.5 mm	3.3 - 8.1 mm
NDP-P25	3.8 - 9.5 mm	3.4 - 9.5 mm

- O ring (other than PTFE)

If O ring are worn out or cracked, replace them.

## 4.3 Installation

For installation, see [Exploded View] on the separate sheet and install in the reverse order of disassembly.

Tightening torque for manifold retainer bolts

		C, N, E, V	T, H, S
NDP-P20	BA□	10 N·m	20 N·m
	BS□		
NDP-P25	BA□	10 N·m	35 N·m
	BS□		

Tightening torque for manifold retainer nuts

		C, N, E, V	T, H, S
NDP-P20	BP□	10 N·m	12 N·m
NDP-P25	BP□		
	BV□		

- NDP-20B□H/T, NDP-25B□H/T type be with 10N·m tightening.

<NOTE>

- Make sure there is no dust on the seal surface and the seal is not damaged.
- Replace the PTFE O ring regardless of its condition.

## 5. Diaphragm and Center rod

### 5.1 Removal

#### ■BA□, BS□ types

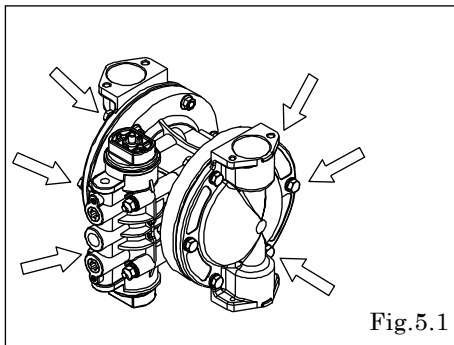

- Remove the ball and valve seat etc. (see “4.1 Removal BA□, BS□ types”)
- Remove the 12 retainer bolts from the out chamber, and remove the out chamber. [Fig.5.1]

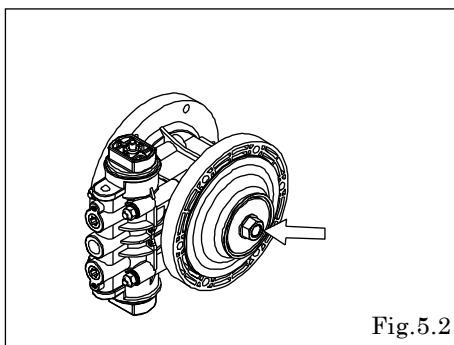

- Remove the nuts on both sides of the center rod. [Fig.5.2]
- After the nuts on one side have been removed, remove the center disk and diaphragm. Remove the diaphragm, center disk and center rod from the opposite side of the main body. [Fig.5.2]

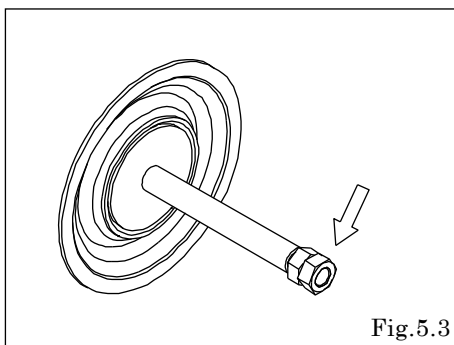

- Remove the nuts on the opposite side using the double nut. [Fig.5.3]
- Remove the coned disk spring, center disk and diaphragm.



■BP□, BV□ types

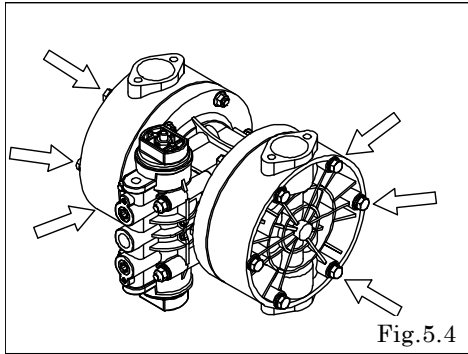

Fig.5.4

- Remove the ball and valve seat etc. (see “4.1 Removal BP□, BV□ types”)
- Remove the 12 retainer bolts from the out chamber, and remove the out chamber. [Fig.5.4]

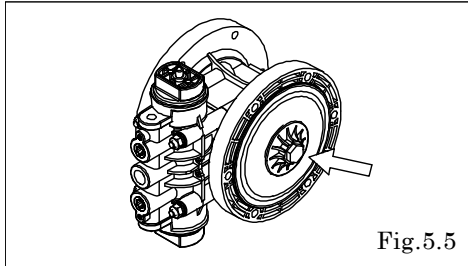

Fig.5.5

- Remove the center disk from one side using the Accessory tool (special tool: Part No. 771244). [Fig.5.5]
- After the center disk (outside) has been removed, remove the diaphragm and the center disk (inside).
- Remove the center disk and center rod from the opposite side of the main body.

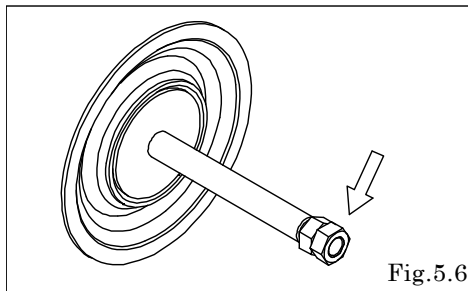

Fig.5.6

- Fix a double nut to one end of the center rod and take the diaphragm and center disk off the opposite end. [Fig.5.6] Be careful not to scratch or score the center rod.

5.2 Inspection

- Diaphragm  
If the diaphragm is worn out or damaged, replace it.  
Never replace just one diaphragm.

Frequency of inspecting the diaphragms  
(Transferring water at room temperature)

CR, NBR, EPDM	10,000,000 cycle
FKM	2,500,000 cycle
PTFE	3,000,000 cycle
TPEE, TPO	15,000,000 cycle

\*The standard in our facility is ‘Air supply pressure 0.5 MPa with no discharge pressure.

\*It’s recommended to conduct an inspection, if 3 months have passed since you start using the pump, or if the number of cycles reaches the above.

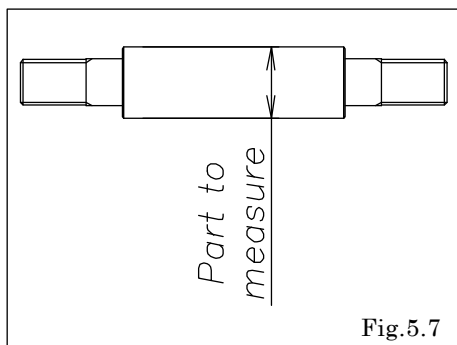

Fig.5.7

- Center rod [Fig.5.7]  
Measure the diameter, and if it is outside the usable range, replace the center rod.

Usable range of center rod

Ø 17.9 – Ø 18.0 mm
--------------------

### 5.3 Installation

#### ■ B□C, B□N, B□E, B□V, B□H, B□S, B□H/T types

For installation, see [Exploded View] on the separate sheet and install in the reverse order of disassembly.

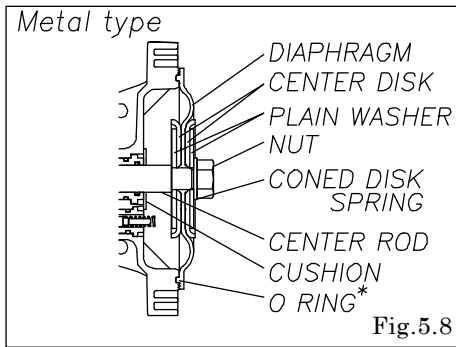

Fig. 5.8

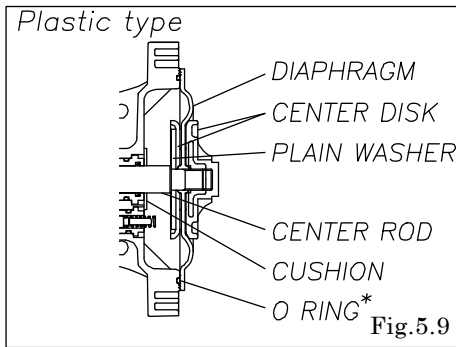

Fig. 5.9

- Apply grease to the center rod, and insert it into the main body.
- For B□H, B□S and B□H/T attach O ring \* into the grooves on both sides of the body. [Fig.5.8] [Fig.5.9]
- Keep the marking "OUTSIDE" to liquid end for CR, NBR, EPDM, FKM diaphragms.
- Keep the convex side to the outside for TPEE, TPO diaphragms.
- For B□C, B□V tighten the center disk using the Accessory tool (special tool:Part No.771244).

#### Tightening torque for center rod

40 N·m
--------

- Draw the center disk to one side, (cf. Fig.5.8) and install the out chamber. Tighten the bolts temporarily. (excluded B□H, B□S, B□H/T)
- Draw the center disk to the opposite side, then turn the diaphragm over (cf. Fig.5.8). And install the out chamber. Tighten the bolts temporarily. (excluded B□H, B□S, B□H/T)
- After installation of the out chambers on both sides, place the pump on a flat surface and stand the pump upright for further assembly.

#### Tightening torque for out chamber.

NDP-P20	B□C, B□N, B□E, B□V	10 N·m
	B□H, B□S, B□H/T	13 N·m
NDP-P25	B□C, B□N, B□E, B□V	10 N·m
	B□H, B□S, B□H/T	20 N·m

<NOTE>

- Make sure there is no dust on the seal surface in order to prevent seal damaged.
- Tighten the bolts that balance should be equal from both side on diagonal line with even torque.

#### ■ B□T types

For installation, see [Exploded View] on the separate sheet and install in the reverse order of disassembly.

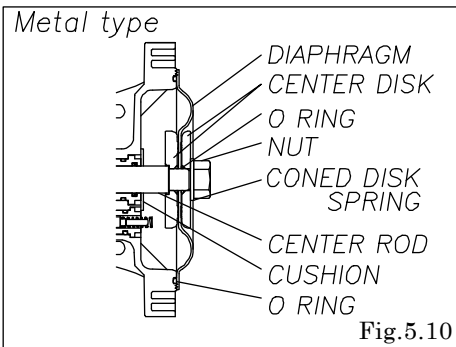

Fig. 5.10

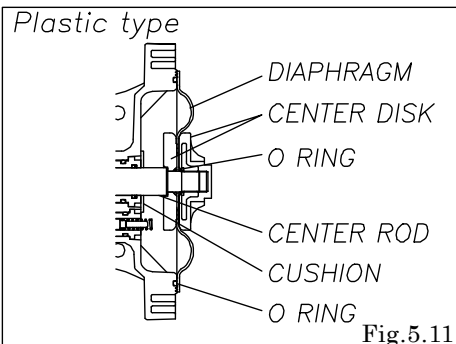

Fig. 5.11

- Apply grease to the center rod, and insert it into the main body.
- Attach O ring into the grooves on both sides of the body. [Fig.5.10] [Fig.5.11]
- Keep the convex side to the outside.
- Put the O ring to both sides of the diaphragm.
- For BPT, BVT tighten the center disk using the Accessory tool (special tool:Part No. 771244)

#### Tightening torque for center rod

40 N·m
--------

- Tighten the out chamber temporarily at first.
- After installation of the out chambers on both sides, place the pump on a flat surface and stand the pump upright for further assembly.

#### Tightening torque for out chamber

NDP-P20	13 N·m
NDP-P25	20 N·m

<NOTE>

- Make sure there is no dust on the seal surface in order to prevent seal damaged.
- Replace the PTFE O ring by new one.
- Tighten the bolts that balance should be equal from both side on diagonal line with even torque.

## 6. Throat bearing and Pilot valve Assembly

### 6.1 Removal

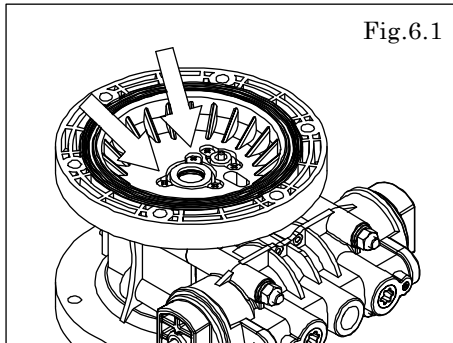

- Remove the diaphragm and center rod (see “5.1 Removal”).
- Remove the 10 retainer screws from the body. [Fig.6.1]

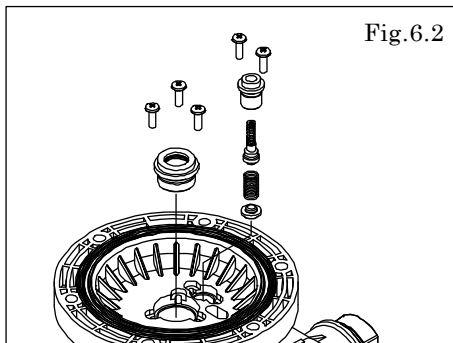

- Draw out the pilot valve assembly. [Fig.6.2]
- Draw out the throat bearing. [Fig.6.2]

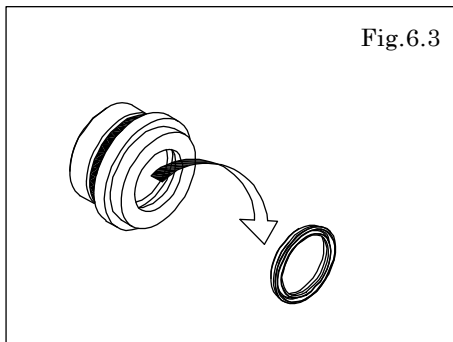

- Remove the packing from the throat bearing. [Fig.6.3]

### 6.2 Inspection

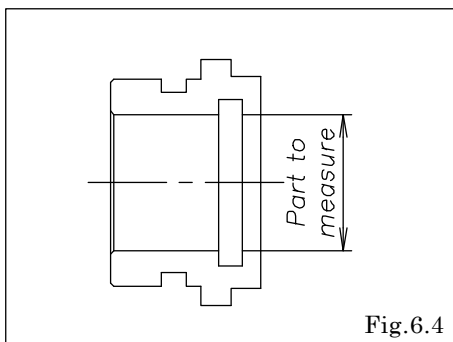

- Throat bearing [Fig.6.4]  
Measure the inside diameter, and if it is outside the usable range, replace the throat bearing.

Usable range of throat bearing

Ø 18.03 - Ø 18.14 mm

- O ring, Packing  
If the O ring is worn out or cracked, replace it.
- Pilot valve assembly  
If the pilot valve is worn out or cracked, replace it.

### 6.3 Installation

For installation, see [Exploded View] on the separate sheet and install in the reverse order of disassembly.

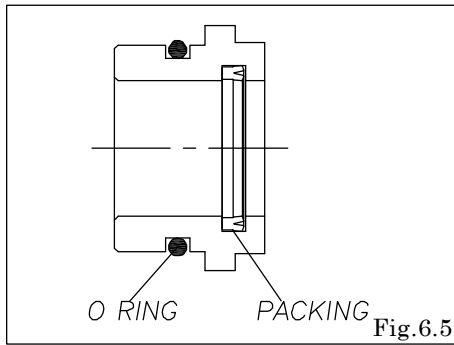

Tightening torque for retainer screws

2 N·m

<NOTE>

- Make sure there is no dust on the seal surface and the seal is not damaged.
- Apply grease to packing.
- At first, tapping screw is tighten by hand and use Phillips head screw driver.
- Do not tighten the tapping screws too much. (Be careful when power tool is used.)

## 7. C Spool Valve Assembly and Sleeve Assembly

### 7.1 Removal

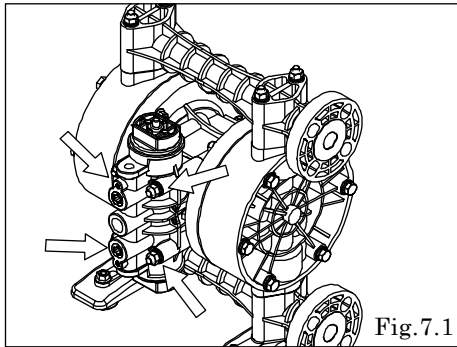

- Remove the 4 retainer bolts from the valve body, and remove the valve body and gasket. [Fig.7.1]

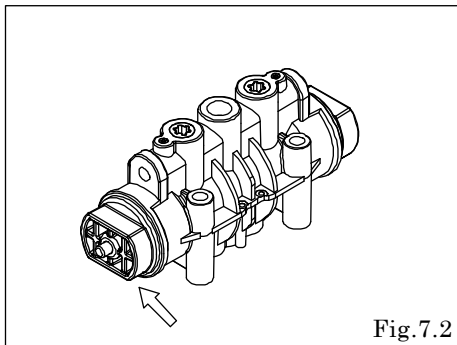

- Remove the cap A with Adjustable angle wrenches, remove packing and draw out the C spool valve assembly. [Fig.7.2]

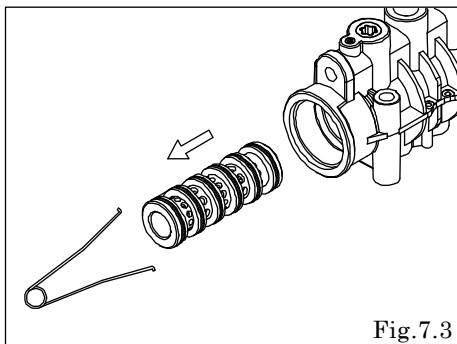

- Remove the sleeve using the sleeve remover (special tool: Part number 713148). [Fig.7.3]

## 7.2 Inspection

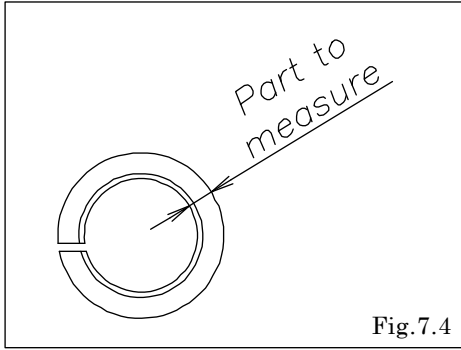

Fig.7.4

- C Spool Valve Assembly  
Seal ring [Fig.7.4]  
Measure the inside thick diameter, and if it is outside the usable range, replace the C Spool Valve Assembly.  
If the seal ring is worn out or cracked, replace C Spool Valve Assembly .

Usable range of Seal ring

2.94 - 3.02 mm

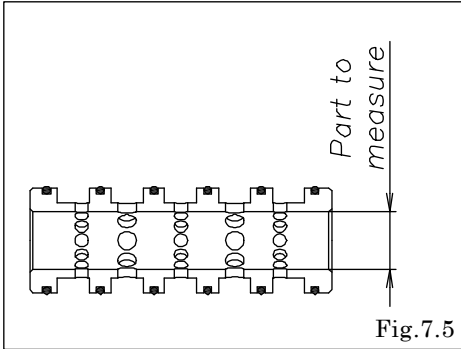

Fig.7.5

- Sleeve Assembly [Fig.7.5]  
Measure the inside diameter, and if it is outside the usable range, replace the sleeve assembly.

Usable range of Sleeve

Ø 18.63 - Ø 18.65 mm

- O ring  
If the O ring is worn out or cracked, replace it.
- <NOTE>
- C Spool Valve Assembly and Sleeve Assembly must be replaced complete set. Unable to replace individual component

## 7.3 Installation

For installation, see [Exploded View] on the separate sheet and install in the reverse order of disassembly.

Tightening torque for Valve body installation bolts

7.5 N·m

<NOTE>

- Make sure there is no dust on the seal surface and it is not damaged.
- Install the sleeve at the center of the valve body. At this point, apply lubricating oil around the sleeve and O ring.

## 8. Retightening of Tie rods

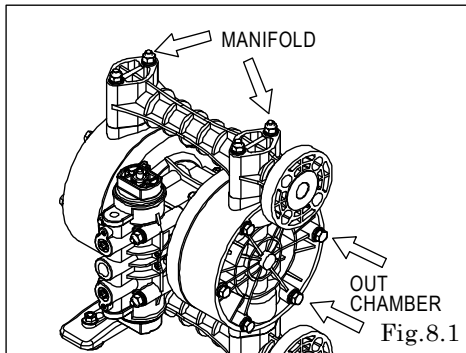

- The torque should be applied on the occasion of
  - (1) Right before the pump to use.
  - (2) There are any leaks of material on daily inspecting a pump.

### ■ Metal type

		Retain bolts for the out chamber	Retain bolts for the manifold
NDP-P20	BAC, BAN, BAE, BAV BSC, BSN, BSE, BSV	10 N·m	10 N·m
	BAT, BST	13 N·m	20 N·m
	BAH, BAS, BAH/T BSH, BSS, BSH/T	13 N·m	10 N·m

		Retain bolts for the out chamber	Retain bolts for the manifold
NDP-P25	BAC, BAN, BAE, BAV BSC, BSN, BSE, BSV	10 N·m	10 N·m
	BAT, BST	20 N·m	35 N·m
	BAH, BAS, BAH/T BSH, BSS, BSH/T	20 N·m	10 N·m

### ■ Plastic type

		Retain bolts for the out chamber	Retain bolts for the manifold
NDP-P20	BPC, BPN, BPE, BPV	10 N·m	10 N·m
	BPT	13 N·m	12 N·m
	BPH, BPS, BPH/T	13 N·m	10 N·m

		Retain bolts for the out chamber	Retain bolts for the manifold
NDP-P25	BPC, BPN, BPE, BPV BVE, BVV	10 N·m	10 N·m
	BPT, BVT, BVH	20 N·m	12 N·m
	BPH, BPS, BPH/T	20 N·m	10 N·m

#### <NOTE>

- Tighten the bolts that balance should be equal from both side on diagonal line with even torque.
- Retighten the Out chamber and then the manifold in this order. [Fig.8.1]



## **YAMADA CORPORATION**

### **INTERNATIONAL DEPARTMENT**

1-1-3, Minami-Magome, Ota ku, Tokyo, 143-8504, Japan

PHONE : +81-(0)3-3777-0241

FAX : +81-(0)3-3777-0584

E-mail : intl@yamadacorp.co.jp

Web : www.yamadacorp.co.jp

## **YAMADA (THAILAND) CO., LTD**

41/79 Moo 6, Bangcha-long, Bangplee, Sumutprakarn 10540, Thailand

PHONE : +66-(0)2-130-0990

FAX : +66-(0)2-130-0993

E-mail : sales@yamada-th.com