



MAINTENANCE MANUAL

YAMADA AIR-OPERATED DOUBLE DIAPHRAGM PUMP

DP-10

WARNING



- For your own safety, be sure to read these procedures carefully before performing maintenance on this product. After reading this document, be sure to keep it handy for future reference.

This maintenance manual covers what you should know about maintenance of the Yamada DP-10 series Diaphragm Pumps.

This edition is based on the standards for the June 2022 production run. Remember, the specifications are always subject to change; therefore, some of the information in this edition may not apply to new specifications.

Warnings and Cautions

For safe use of this product, be sure to note the following: In this document, warnings and cautions are indicated by symbols. These symbols are for those who will operate this product and for those who will be nearby, for safe operation and for prevention of personal injury and property damage. The following warning and caution symbols have the meanings described below. Be sure to remember their meanings.



WARNING : If you ignore the warning described and operate the product in an improper manner, there is danger of serious bodily injury or death.



CAUTION : If you ignore the caution described and operate the product in an improper manner, there is danger of personal injury or property damage.

Furthermore, to indicate the type of danger and damage, the following symbols are also used along with those mentioned above:



This symbol indicates a DON'T, and will be accompanied by an explanation on something you must not do.



This symbol indicates a DO, and will be accompanied by instructions on something you must do in a certain situation.

WARNING



- Before starting maintenance work, cut off the feed air and clean the pump. If air pressure or residue remain in the pump, there is danger of explosion, or possible poisoning resulting in serious injury or death if chemicals adhere to the skin or are accidentally swallowed. (For details on cleaning the pump, refer to Chapter 6 of the Operation Manual.)



- When replacing parts, be sure to use the recommended genuine parts or Equivalents. Use of other parts may cause a malfunction of the product. (Refer to Parts List the separate sheets.)

CAUTION



- When it is instructed that special tools must be used, be sure to use the specified tools. Otherwise, the pump may be damaged.



- Refer to “10.1 Specifications” in the Operation Manual. Also, remember that the pump is heavy, and extreme care must be taken when lifting it.

Table of Contents

·Warnings and Cautions	
·Table of Contents	
1. Principles of operation	1
2. Maintenance and Tools	
2.1 Maintenance	1
2.2 General tools	1
2.3 Misc.	1
3. Ordering Replacement parts	1
4. Balls and Valve seats	
4.1 Removal	
■BA□, BS□ types	2
■BP□ type	2
4.2 Inspection	3
4.3 Installation	3
5. Diaphragm	
5.1 Removal	
■BA□, BS□ types	4
■BP□ type	4
5.2 Inspection	5
5.3 Installation	
■B□H, B□S types	5
■B□C, B□N, B□T types	5
6. Center rod, Body and Guide bushing	
6.1 Removal	6
6.2 Inspection	6
6.3 Installation	6
7. Spool valve case and Spool Assembly	
7.1 Removal	7
7.2 Inspection	7
7.3 Installation	7
8. Retightening of Tie rods	8

1. Principles of operation

There are two diaphragms fixed to the center rod, one at each end. When compressed air is supplied to air chamber b (right side, see Fig.1.1), the center rod moves to the right, the material in material chamber B is pushed out, and at the same time material is sucked into material chamber A.

When the center rod is moved full-stroke to the right, the air switch valve is switched, compressed air is sent to air chamber a (left side, see Fig.1.2), and the center rod moves to the left. The material in material chamber A is pushed out, and at the same time material is sucked into material chamber B.

Through repetition of this operation, material is repeatedly taken in and discharged out.

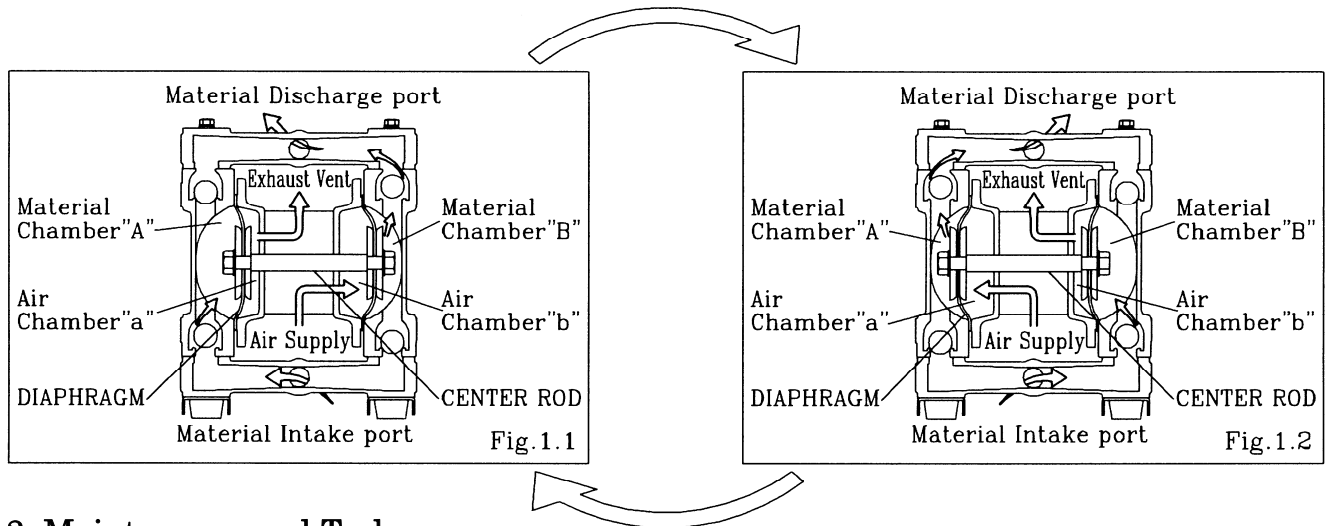

2. Maintenance and Tools

2.1 Maintenance

It is recommended that the pump should be regularly inspected, as this kind of diaphragm pump can be used in many different circumstances such as pressures, temperatures, viscosities, or corrosiveness. It's very useful for your future reference to keep records of the pump conditions for every inspection.

The regular inspection includes the air valve, diaphragms, balls, valve seats, or O-rings.

When it comes to diaphragms, in particular, both of the diaphragms should be replaced at one time, as they tend to be worn out or have some cracks on the surfaces. Please refer to 'usage range' in each section regarding the frequency of the replacement of the other spare parts.

2.2 General tools

- Socket wrenches 13 mm
- Hexagonal box wrenches 5 mm, 6 mm
- Open-end wrenches 21 mm (BP□)
- Snap ring pliers

2.3 Misc.

- Assembly oil Turbine oil none addition class 1 (equivalent to ISO VG32 grade)
- Nuts M8 ×1.25 (BA□, BS□)
- Thread locker
- Grease Urea grease grade (NLGI) No.2

3. Ordering Replacement parts

For accurate and speedy shipment of parts, be sure to order the right parts for your model to distributor. Indicate the part numbers, descriptions, and quantities

4. Balls and Valve seats

4.1 Removal

■BA□, BS□ types

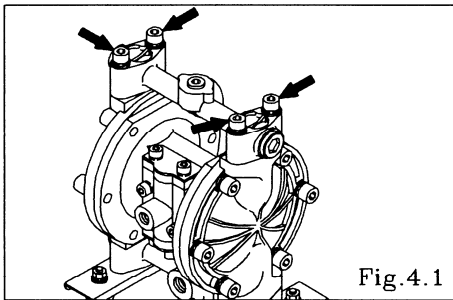

- Remove the 4 retainer bolts from the out manifold, and remove the out manifold. [Fig.4.1]

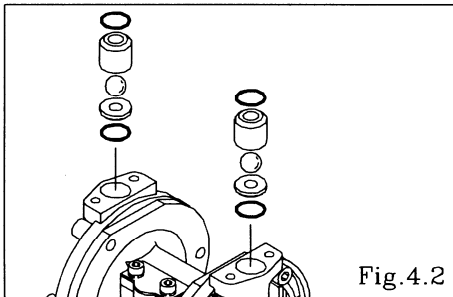

- Remove the O ring, valve stopper, ball and valve seat. [Fig.4.2]

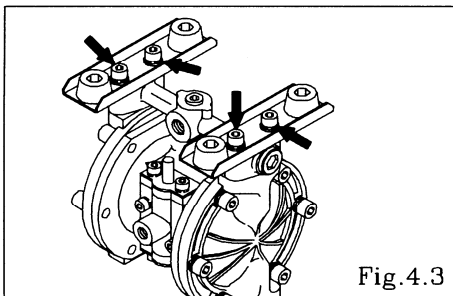

- Turn over the main body assembly. [Fig.4.3]
- Remove the 4 retainer bolts from the in manifold, and remove the in manifold. [Fig.4.3]

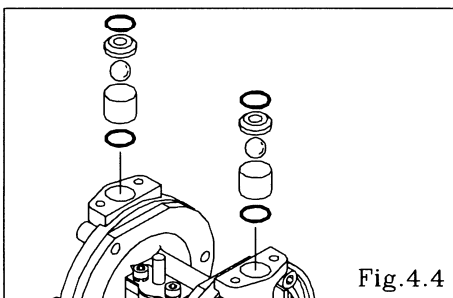

- Remove the O ring, valve seat, ball and valve stopper. [Fig.4.4]

■BP□type

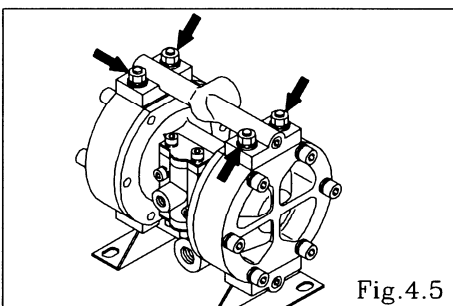

- Remove the 4 retainer nuts from the out manifold, and remove the out manifold. [Fig.4.5]

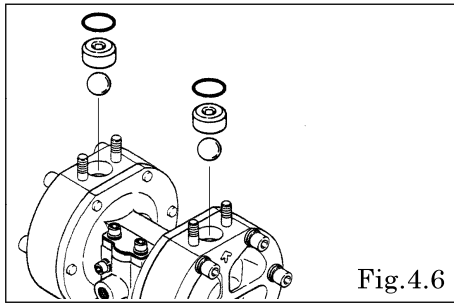

Fig.4.6

- Remove the O ring, valve stopper, ball and valve seat. [Fig.4.6]

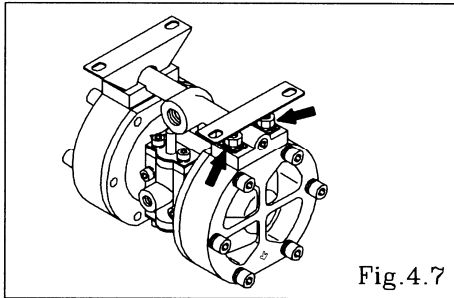

Fig.4.7

- Turn over the main body assembly. [Fig.4.7]
- Remove the 4 retainer nuts from the in manifold, and remove the in manifold. [Fig.4.7]

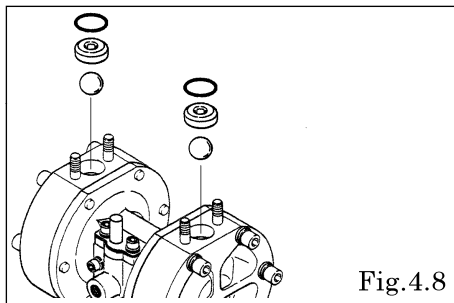

Fig.4.8

- Remove the O ring (excluded BPC, BPN), ball and valve seat. [Fig.4.8]

4.2 Inspection

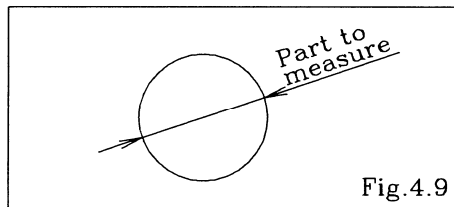

Fig.4.9

- Ball [Fig.4.9]
Measure the outside diameter, and if it is outside the usable range, replace the ball.

Usable range of ball SØ14.3 - SØ16.3 mm
--

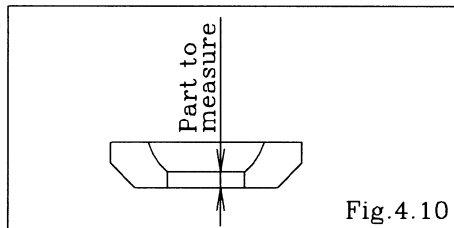

Fig.4.10

- Valve seat [Fig.4.10]
Measure the dimension shown at left, and if it is outside the usable range, replace the seat.

Usable range of valve seat	
BA□, BS□, BPH, BPT, BPS	2.0 - 5.1 mm
BPC, BPN	2.0 - 6.7 mm

- O ring (other than PTFE)
If O rings are worn out or cracked, replace them.

4.3 Installation

For installation, see [Exploded View] on the separate sheet and install in the reverse order of disassembly.

Tightening torque for manifold retainer bolts	
BA□, BS□	12 N·m
BP□	8 N·m

<NOTE>

- Make sure there is no dust on the seal surface and the seal is not damaged.
- Replace the PTFE O ring regardless of its condition.

5. Diaphragm

5.1 Removal

■ BA□, BS□ types

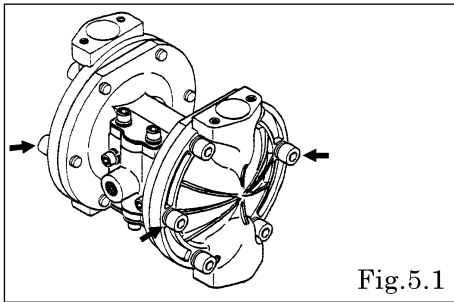

- Remove the ball and valve seat etc. (see “4.1 Removal BA□, BS□ types”)
- Remove the 12 retainer bolts from the out chamber, and remove the out chamber. [Fig.5.1]

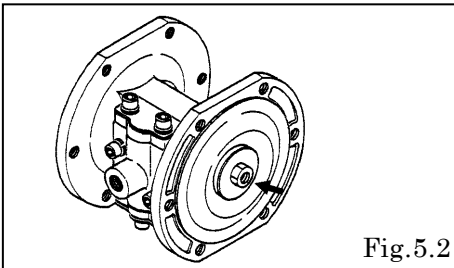

- Remove the nuts on both sides of the center rod. [Fig.5.2]
- After the nuts on one side have been removed, remove the center disk and diaphragm. [Fig.5.2]

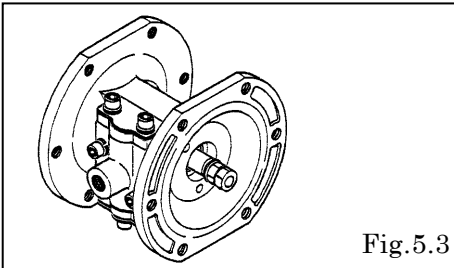

- Remove the nuts on the opposite side using the double nut. [Fig.5.3]
- Remove the coned disk spring, center disk and diaphragm.

■ BP□ type

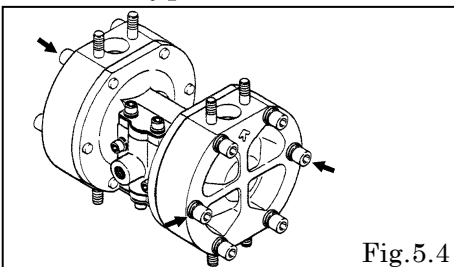

- Remove the ball and valve seat etc. (see “4.1 Removal BP□ Type”)
- Remove the 12 retainer bolts from the out chamber, and remove the out chamber. [Fig.5.4]

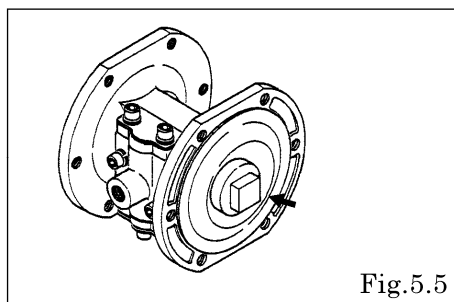

- Remove the center disk from one side. [Fig.5.5]
- After the center disk (outside) has been removed, remove the diaphragm and the center disk (inside).

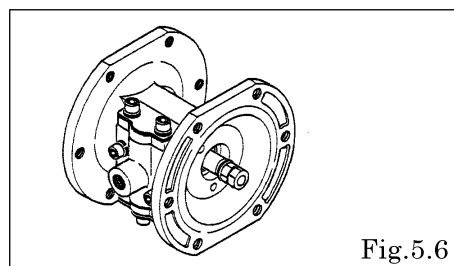

- Remove the center disk and diaphragm from the opposite side using the double nut. [Fig.5.6]
Be careful not to scratch or score the center rod.

5.2 Inspection

- Diaphragm

If the diaphragm is worn out or damaged, replace it.
Never replace just one diaphragm.

Frequency of inspecting the diaphragms
(Transferring water at room temperature)

CR, NBR, PTFE	10,000,000 cycle
TPEE, TPO	15,000,000 cycle

*The standard in our facility is 'Air supply pressure 0.5 MPa with no discharge pressure.

*It's recommended to conduct an inspection, if 3 months have passed since you start using the pump, or if the number of cycles reaches the above.

5.3 Installation

■ B□H, B□S types

For installation, see [Exploded View] on the separate sheet and install in the reverse order of disassembly.

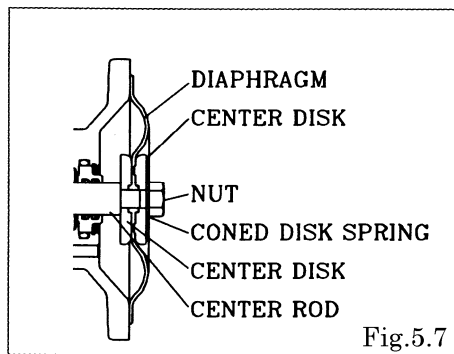

Fig.5.7

- Apply assembly grease to the center rod, and insert it into the main body.
- Keep the convex side to the outside (cf. Fig.5.7).
- Tighten the center disk using the open-end wrenches for B□ type.
(No coned disk springs and nuts are needed.)
- Tighten the out chamber temporarily at first.
- After installation of the out chambers on both sides, place the pump on a flat surface and stand the pump upright for further assembly.

Tightening torque for center rod and out chamber

center rod	out chamber
14 N•m	12 N•m

<NOTE>

- Make sure there is no dust on the seal surface in order to prevent seal damaged.
- Tighten the bolts gradually in a diagonal sequence with even torque. [Fig.5.8].

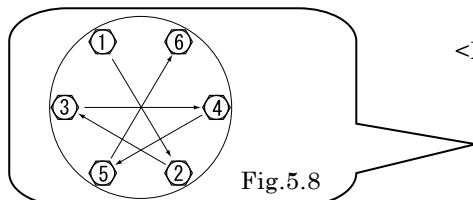

Fig.5.8

■ B□C, B□N, B□T types

For installation, see [Exploded View] on the separate sheet and install in the reverse order of disassembly.

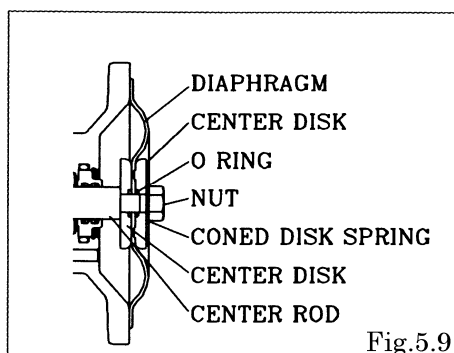

Fig.5.9

- Apply Assembly grease to the center rod, and insert it into the main body.
- Keep the marking "LIQUID" to liquid end for CR, NBR diaphragms.
- Keep the convex side to the outside for PTFE diaphragm.
- Install the O ring (cf. Fig.5.8).
- Tighten the center disk using the open-end wrenches for B□ type.
(No coned disk springs and nuts are needed.)
- After installation of the out chambers on both sides, place the pump on a flat surface and stand the pump upright for further assembly.

Tightening torque for center rod and out chamber.

center rod	out chamber
14 N•m	12 N•m

<NOTE>

- Make sure there is no dust on the seal surface in order to prevent seal damaged.
- Replace the PTFE O ring by new one.
- Tighten the bolts gradually in a diagonal sequence with even torque. [Fig.5.10].

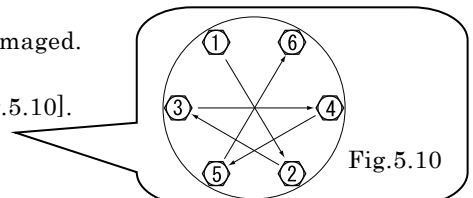

Fig.5.10

6. Center rod, Body and Guide bushing

6.1 Removal

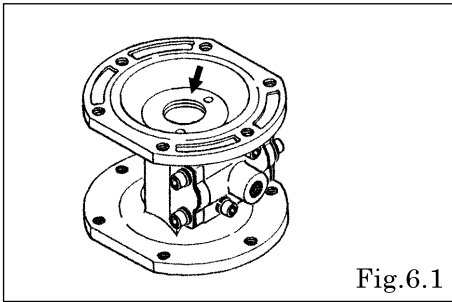

Fig.6.1

- Remove the diaphragm etc. (see “5.1 Removal”)
- Remove the snap ring using the snap ring pliers, and remove the guide bushing, spacer and center rod assembly. [Fig.6.1]

6.2 Inspection

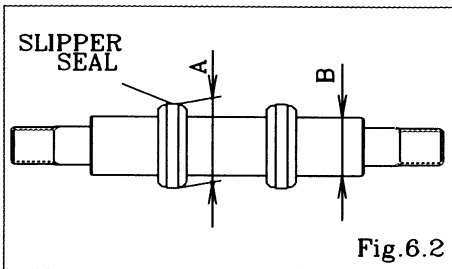

Fig.6.2

- Center rod assembly [Fig.6.2]
Measure the outside diameter (A), and if it is outside the usable range, replace the slipper seal.

Usable range of Slipper seal (A)

Ø 19.9 - Ø 20.0 mm

- Measure the outside diameter (B), and if it is outside the usable range, replace the center rod Slipper seal.

Usable range of Center rod (B)

Ø 13.9 - Ø 14.0 mm

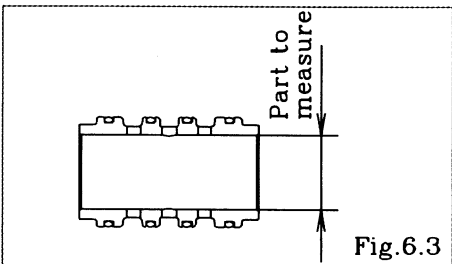

Fig.6.3

- Sleeve [Fig.6.3]
Measure the inside diameter, and if it is outside the usable range, replace the Sleeve.
Remove the Sleeve from the Spacer side.

Usable range of sleeve

Ø 20.00 - Ø 20.08 mm

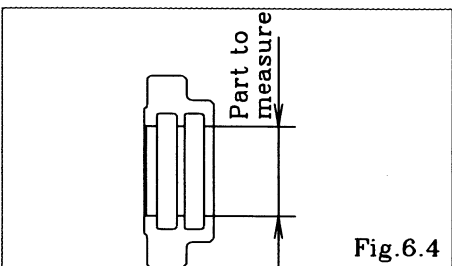

Fig.6.4

- Guide bushing [Fig.6.4]
Measure the inside diameter, and if it is outside the usable range, replace the guide bushing.

Usable range of Guide bushing

Ø 14.02 - Ø 14.10 mm

- O ring
If the O ring is worn out or cracked, replace it.

6.3 Installation

For installation, see [Exploded View] on the separate sheet and install in the reverse order of disassembly.

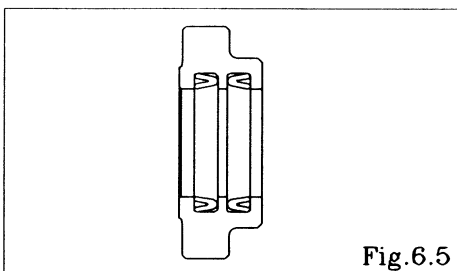

Fig.6.5

<NOTE>

- Make sure there is no dust on the seal surface and it is not damaged.
- Apply grease to packing.

7. Spool valve case and Spool Assembly

7.1 Removal

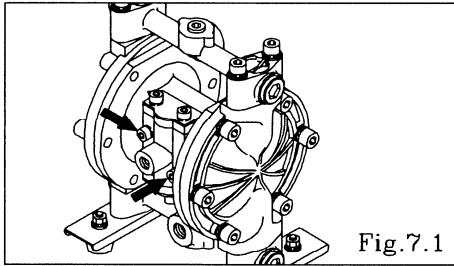

- Remove the 2 retainer bolts from the spool valve case, and remove the spool valve case. [Fig.7.1]

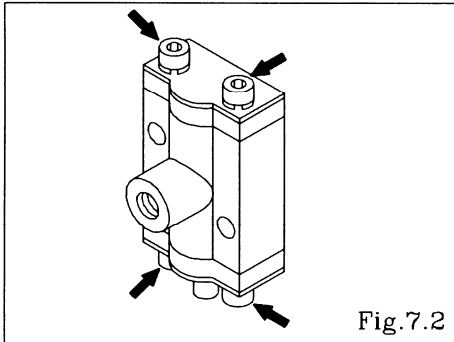

- Remove the 2 retainer bolts from the cap, and remove the reinforcement plate A, cap and reset button. [Fig.7.2]
- Remove the 2 retainer bolts from the cap, and remove the reinforcement plate B, and cap. [Fig.7.2]
- Remove the spool valve assembly from the spool valve case.

7.2 Inspection

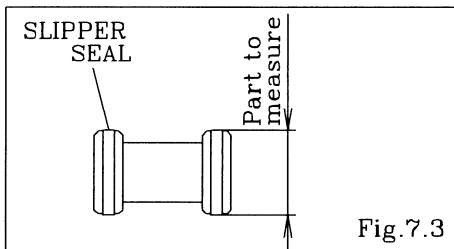

- Spool valve assembly [Fig.7.3]
Measure the outside diameter, and if it is outside the usable range, replace the slipper seal.

Usable range of spool valve assembly

Ø 19.9 - Ø 20.0 mm

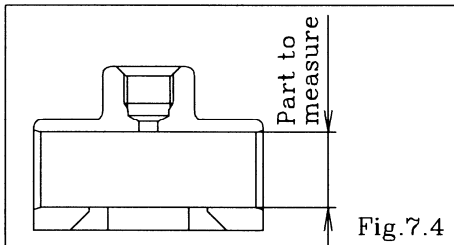

- Spool valve case [Fig.7.4]
Measure the inside diameter, and if it is outside the usable range, replace the Spool valve case.

Usable range of spool valve case

Ø 20.00 - Ø 20.08 mm

7.3 Installation

For installation, see [Exploded View] on the separate sheet and install in the reverse order of disassembly.

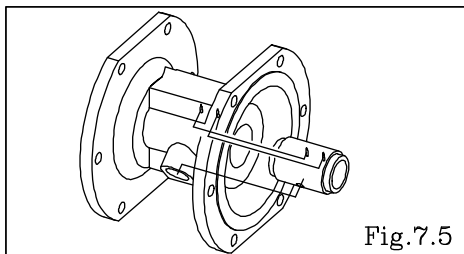

Tightening torque for installation Cap

6 N·m

Tightening torque for installation Spool valve case

6 N·m

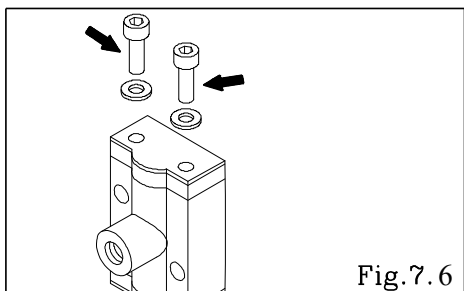

- Sleeve [Fig.7.5]
When inserting the sleeve into the body, please make sure the position of the 3 holes in the sleeve match the corresponding holes in the body.

- Reinforcement plate A, Reinforcement plate B [Fig.7.6]
Apply the Thread locker to the retainer bolts.

<NOTE>

- Make sure there is no dust on the seal surface and it is not damaged.

8. Retightening of Tie rods

■ Metal type

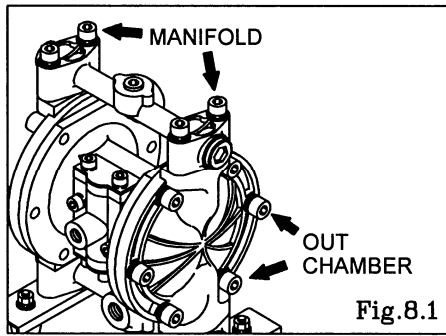

- All bolts should be retorqued:
 - (1) Right before start up.
 - (2) There are any leaks of material on daily inspecting a pump.

		Retain bolts for the out chamber	Retain bolts for the manifold
DP-10	BA□[-D]	12 N·m	12 N·m
	BS□[-D]		

<NOTE>

- Retighten the Out chamber and then the manifold in this order. [Fig.8.1]
- Tighten the bolts in the order shown.

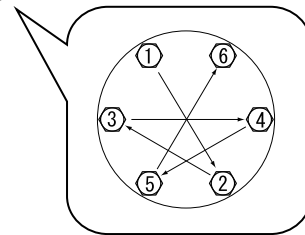

■ Plastic type

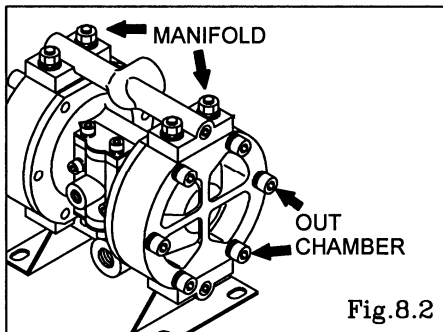

- All bolts should be retorqued:
 - (1) Right before start up.
 - (2) There are any leaks of material on daily inspecting a pump.

		Retain bolts for the out chamber	Retain bolts for the manifold
DP-10	BP□	12 N·m	8 N·m

<NOTE>

- Retighten the Out chamber and then the manifold in this order. [Fig.8.2]
- Tighten the bolts in the order shown.

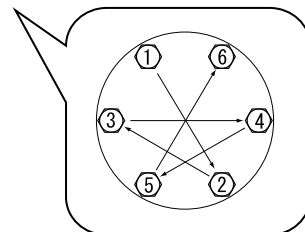

YAMADA CORPORATION

INTERNATIONAL DEPARTMENT

1-1-3, Minami-Magome, Ota ku, Tokyo, 143-8504, Japan

PHONE : +81-(0)3-3777-0241

FAX : +81-(0)3-3777-0584

E-mail : intl@yamadacorp.co.jp

Web : www.yamadacorp.co.jp

YAMADA (THAILAND) CO., LTD

41/79 Moo 6, Bangcha-long, Bangplee, Sumutprakarn 10540, Thailand

PHONE : +66-(0)2-130-0990

FAX : +66-(0)2-130-0993

E-mail : sales@yamada-th.com