

MAINTENANCE MANUAL

YAMADA AIR-OPERATED DOUBLE DIAPHRAGM PUMP

NDP-40
NDP-50
NDP-500
NDP-80
NDP-800

WARNING



- For your own safety, be sure to read these procedures carefully before performing maintenance on this product. After reading this document, be sure to keep it handy for future reference.

This maintenance manual covers what you should know about maintenance of the Yamada NDP-40 series, NDP-50 series, NDP-500 series, NDP-80 series, and NDP-800 series Diaphragm Pumps.

This edition is based on the standards for the April 2026 production run. Remember, the specifications are always subject to change; therefore, some of the information in this edition may not apply to new specifications.

Warnings and Cautions

For safe use of this product, be sure to note the following: In this document, warnings and cautions are indicated by symbols. These symbols are for those who will operate this product and for those who will be nearby, for safe operation and for prevention of personal injury and property damage. The following warning and caution symbols have the meanings described below. Be sure to remember their meanings.



WARNING : If you ignore the warning described and operate the product in an improper manner, there is danger of serious bodily or property damage.



CAUTION : If you ignore the caution described and operate the product in an improper manner, there is danger of personal injury or property damage.

Furthermore, to indicate the type of danger and damage, the following symbols are also used along with those mentioned above:



This symbol indicates a DON'T, and will be accompanied by an explanation on something you must not do.



This symbol indicates a DO, and will be accompanied by instructions on something you must do in a certain situation.

WARNING



- Before starting maintenance work, cut off the feed air and clean the pump. If air pressure or residue remain in the pump, there is danger of explosion, or possible poisoning resulting in serious injury or death if chemicals adhere to the skin or are accidentally swallowed. (For details on cleaning the pump, refer to Chapter 6 of the Operation Manual.)



- When replacing parts, be sure to use the recommended genuine parts or Equivalents. Use of other parts may cause a malfunction of the product. (Refer to Parts list the separate sheets.)

CAUTION



- When it is instructed that special tools must be used, be sure to use the specified tools. Otherwise, the pump may be damaged.



- Refer to “10.1 Specifications” in the Operation Manual. Also, remember that the pump is heavy, and extreme care must be taken when lifting it.

Table of Contents

·Warnings and Cautions	
·Table of Contents	
1. Principles of operation	1
2. Maintenance and Tools	
2.1 Maintenance	1
2.2 General tools	1
2.3 Special tools	1
2.4 Misc.	1
3. Ordering Replacement parts	1
4. Balls and Valve seats	
4.1 Removal	
■ BA□, BS□, BF□ types	2
■ NDP-40 BP□·BV□ types	3
■ NDP-50 BP□·BV□, NDP-80 BP□ types	4
4.2 Inspection	5
4.3 Installation	5
5. Diaphragm and Center rod	
5.1 Removal	
■ BA□, BS□, BF□ types (excluding B□W)	6
■ BP□, BV□ types (excluding B□W)	6
■ B□W type	7
5.2 Inspection	8
5.3 Installation	
■ B□C, B□N, B□E, B□V, B□H, B□S, B□H/T types	8
■ B□T type	9
■ B□W type	10
6. Throat bearing and Pilot valve	
6.1 Removal	13
6.2 Inspection	13
6.3 Installation	13
7. C Spool valve assembly	
7.1 Removal	14
7.2 Inspection	15
7.3 Installation	15
8. Retightening of Tie rods	16

1. Principles of operation

There are two diaphragms fixed to the center rod, one at each end. When compressed air is supplied to air chamber b (right side, see Fig.1.1), the center rod moves to the right, the material in material chamber B is pushed out, and at the same time material is sucked into material chamber A.

When the center rod is moved full-stroke to the right, the air switch valve is switched, compressed air is sent to air chamber a (left side, see Fig.1.2), and the center rod moves to the left. The material in material chamber A is pushed out, and at the same time material is sucked into material chamber B.

Through repetition of this operation, material is repeatedly taken in and discharged out.

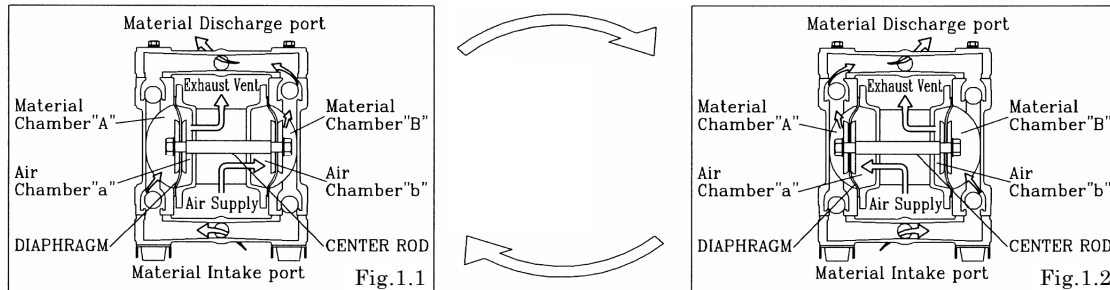

2. Maintenance and Tools

2.1 Maintenance

It is recommended that the pump should be regularly inspected, as this kind of diaphragm pump can be used in many different circumstances such as pressures, temperatures, viscosities, or corrosiveness. It's very useful for your future reference to keep records of the pump conditions for every inspection.

The regular inspection includes the air valve, diaphragms, balls, valve seats, or O-rings.

When it comes to diaphragms, in particular, both of the diaphragms should be replaced at one time, as they tend to be worn out or have some cracks on the surfaces. Please refer to 'usage range' in each section regarding the frequency of the replacement of the other spare parts.

2.2 General tools

- Socket wrenches 13 mm, 17 mm, 19 mm (except with the NDP-40 BP□, BV□), 24 mm (BA□, BS□, BF□)
- Hexagonal box wrenches 5 mm, 6 mm
- Small crowbars 2 (B□C, B□N, B□E, B□V)
- Open-end wrenches 17 mm (NDP-40 BP□, BV□), 19 mm (BA□, BS□, BF□), 24 mm (BA□, BS□, BF□) , 30 mm (NDP-80 B□W, NDP-800 BSW)
- Plastic hammer
- Plyer

2.3 Special tools

- Outer disk wrench (sold separately)
Purpose: Removing the center disk of BP□, BV□ types
- Sleeve remover (sold separately)
Purpose: For removing sleeve

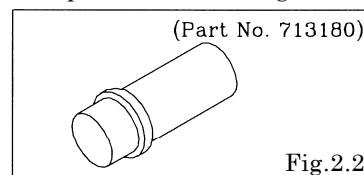
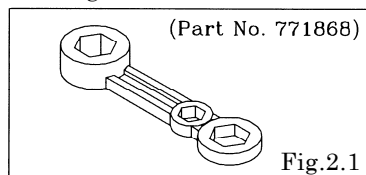

2.4 Misc.

- Assembly oil Turbine oil none addition class 1 (equivalent to ISO VG32 grade)
- Nuts M16 X 1.5, M20 X 1.5 (NDP-80 B□W, NDP-800 B□W)
- Thread locker Urea grease grade (NLGI) No. 2
- Grease Urea grease grade (NLGI) No. 2
- Air regulator The one which is adjustable in 0.1 MPa increments (BSW)

3. Ordering Replacement parts

For accurate and speedy shipment of parts, be sure to order the right parts for your model to distributor. Indicate the part numbers, descriptions, and quantities.

4. Balls and Valve seats

4.1 Removal

■ BA□, BS□, BF□ types

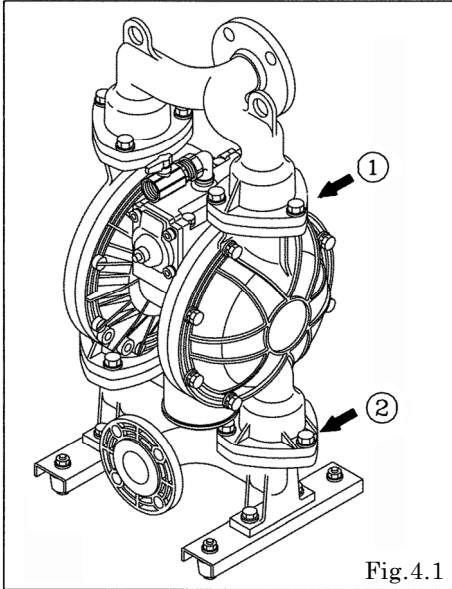

Fig.4.1

- Remove the 6 (8 on the NDP-500, NDP-80, and NDP-800) retainer bolts "1" from the out manifold, and remove the out manifold. [Fig.4.1]

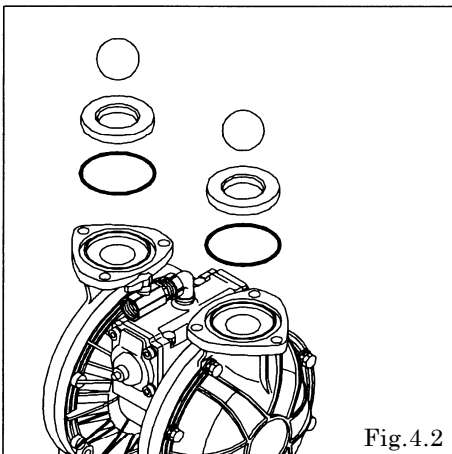

Fig.4.2

- Remove the ball, valve seat and O ring. [Fig.4.2]

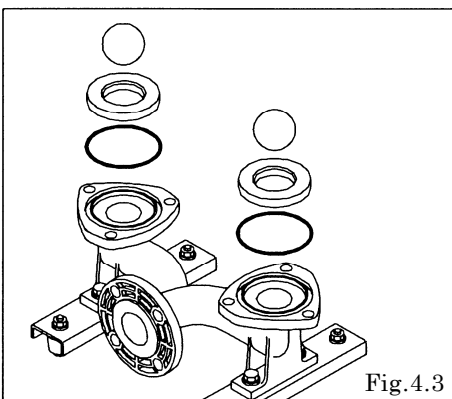
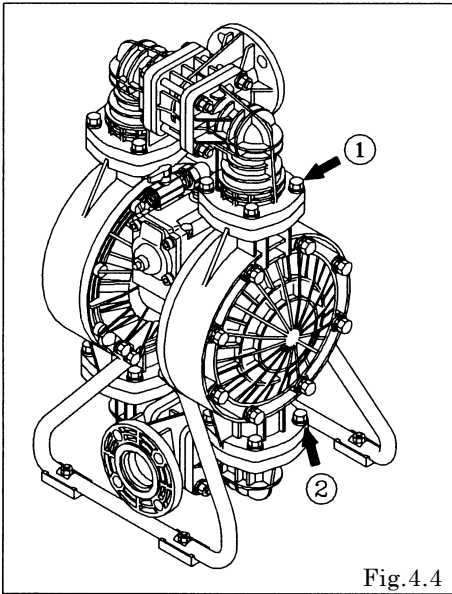

Fig.4.3

- Remove the 6 (8 on the NDP-500, NDP-80, and NDP-800) retainer bolts "2" from the in manifold, and remove the in manifold. [Fig.4.1]
- Remove the ball, valve seat and O ring. [Fig.4.3]

■ NDP-40 BP□·BV□ types



- Remove the 8 retainer bolts "1" from the out manifold, and remove the out manifold. [Fig.4.4]

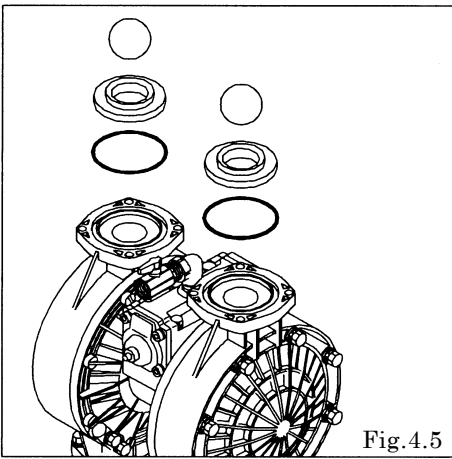

- Remove the ball, valve seat and O ring. [Fig.4.5]

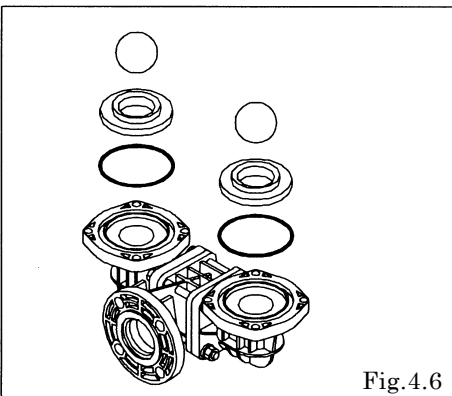

- Remove the 8 retainer bolts "2" from the in manifold, and remove the in manifold. [Fig.4.4]
- Remove the ball, valve seat and O ring. [Fig.4.6]

■ NDP-50 BP□·BV□, NDP-80 BP□ types

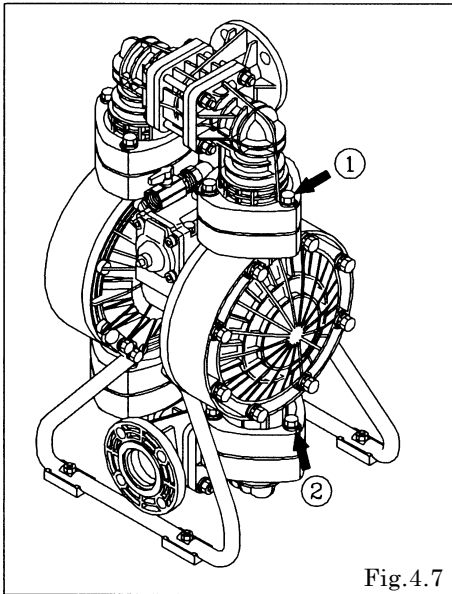

- Remove the 6 (8 on the NDP-80) retainer bolts "1" from the out manifold, and remove the protector and out manifold. [Fig.4.7]

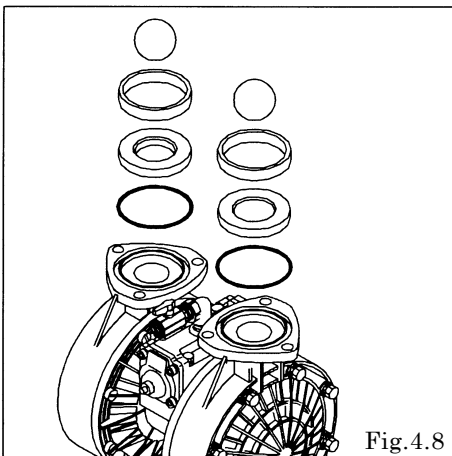

- Remove the ball, valve guide (only NDP-80), valve seat and O ring. [Fig.4.8]

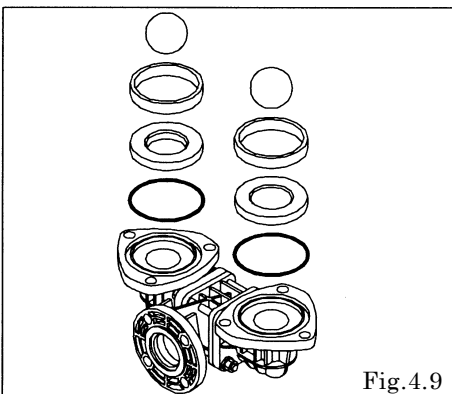

- Remove the 6 (8 on the NDP-80) retainer bolts "2" from the in manifold, and remove the protector and in manifold. [Fig.4.7]
- Remove the ball, valve guide (only NDP-80), valve seat and O ring. [Fig.4.9]

4.2 Inspection

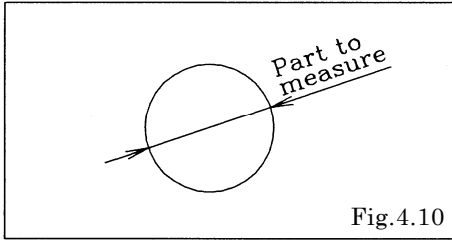

- Ball [Fig.4.10]

Measure the outside diameter, and if it is outside the usable range, replace the ball.

Usable range of ball

NDP-40	SØ 45.0 - SØ 51.5 mm
NDP-50 NDP-500	SØ 56.7 - SØ 64.9 mm
NDP-80 NDP-800	SØ 81.0 - SØ 92.7 mm

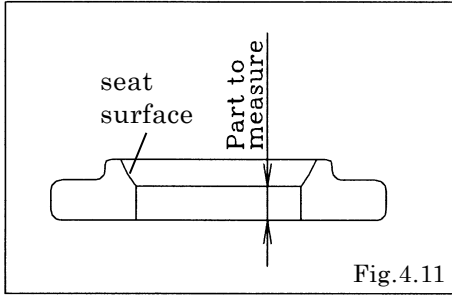

- Valve seat [Fig.4.11]

If you find a scar on the seat surface, please replace it for the new one.

Measure the dimension shown at left, and if it is outside the usable range, replace the seat.

Usable range of valve seat

	B□C, B□N, B□E	B□T
	B□V, B□H, B□S, B□H/T	
NDP-40	4.6 - 11.5 mm	1.7 - 4.2 mm
NDP-50 NDP-500 NDP-80 NDP-800	5.0 - 12.5 mm	

- O ring (other than PTFE)

If O rings are worn out or cracked, replace them.

4.3 Installation

For installation, see [Exploded View] on the separate sheet and install in the reverse order of disassembly.

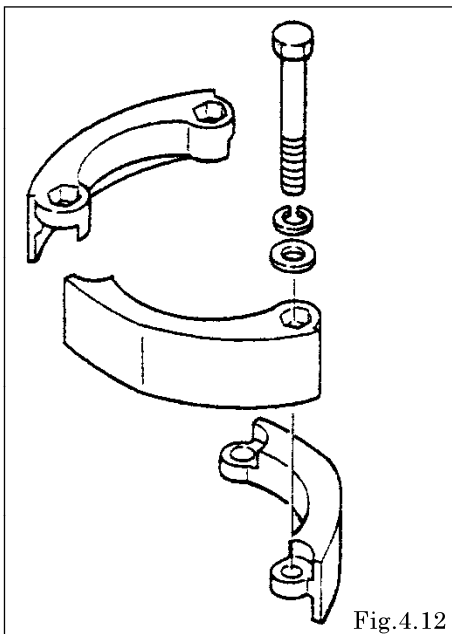

Tightening torque for manifold retainer bolts

NDP-40	BA□、BS□、BF□	25 N·m
	BP□、BV□	20 N·m
NDP-50 NDP-80 NDP-800	BA□、BS□、BF□	25 N·m
	BP□、BV□	
NDP-500	BS□	20 N·m

<
NOTE>

- Make sure there is no dust on the seal surface and the seal is not damaged.
- Replace the PTFE O ring regardless of its condition.
- Match the convex and concave parts of the protector.

[Fig.4.12] (NDP-50 BP□·BV□, NDP-80 BP□)

5. Diaphragm and Center rod

5.1 Removal

■BA□, BS□, BF□ types (excluding B□W)

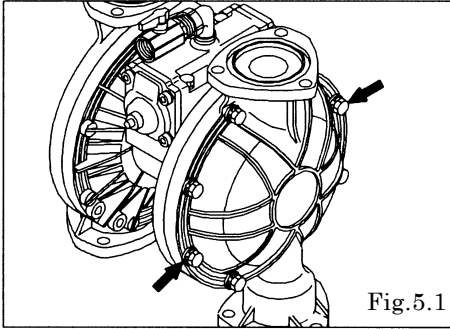

- Remove the ball and valve seat etc. (see “4.1 Removal BA□, BS□, BF□ types”)
- Remove the 16 (24 on the NDP-80 and NDP-800) retainer bolts from the out chamber, and remove the out chamber. [Fig.5.1]

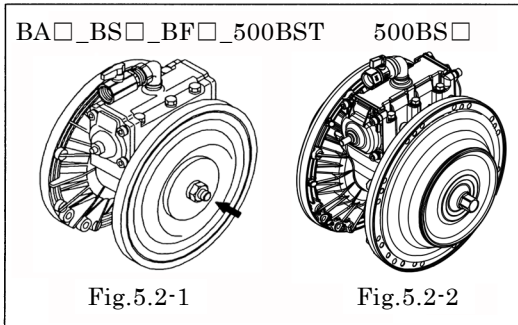

- Remove the nut on one side of the center rod. [Fig.5.2-1]
- After the nut on one side have been removed, remove the center disk and diaphragm. Remove the diaphragm, center disk and center rod from the opposite side of the main body. [Fig.5.2-1]
- Remove the center disk from one side using the general tool. [Fig.5.2-2]
- After the center disk (outside) has been removed, remove the diaphragm and the center disk (inside). Remove the diaphragm, center disk and center rod from the opposite side of the main body. [Fig.5.2-2]

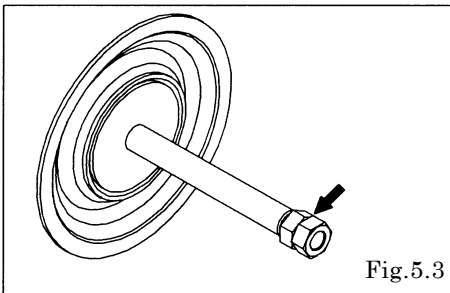

- Remove the nut on the opposite side using the double nut. Then, remove the coned disk spring, center disk and diaphragm. (excluding 500BS□) [Fig.5.3]
- Remove the center disk (outside) on the opposite side using the double nut. Then, remove the center disk (inside) and diaphragm. (only 500BS□) [Fig.5.3]

<NOTE>

Be careful not to scratch or score the center rod.

■BP□, BV□ types (excluding B□W)

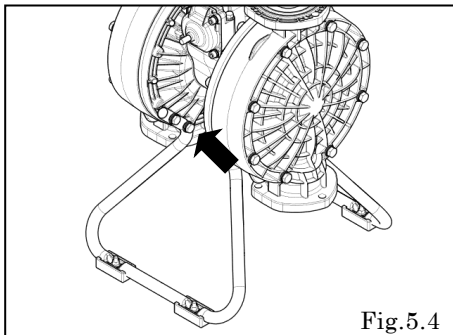

- Remove the ball etc. (see “4.1 Removal BP□, BV□ types”)
- Remove the 8 (4 on the NDP-40) retainer bolts from the stand body, and remove the stand body. [Fig.5.4]

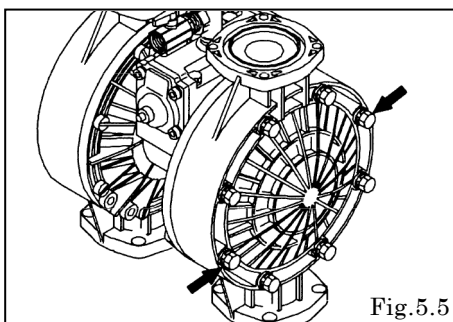

- Remove the 16 (24 on the NDP-80) retainer bolts from the out chamber, and remove the out chamber. [Fig.5.5]

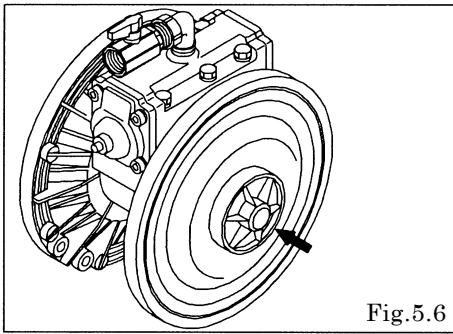

- Remove the center disk from one side using the Outer disk wrench (special tool: Part No. 771868). [Fig.5.6]
- After the center disk (outside) has been removed, remove the diaphragm and the center disk (inside).
- Remove the diaphragm, center disk and center rod from the opposite side of the main body.

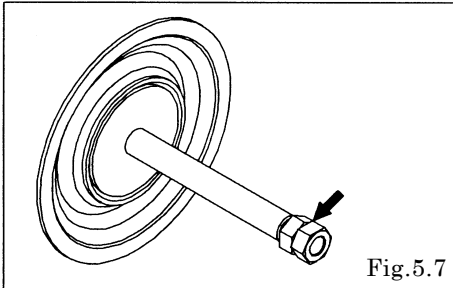

- Remove the center disk (outside) on the opposite side using the double nut. Then, remove the center disk (inside) and diaphragm. [Fig.5.7]

<NOTE>

Be careful not to scratch or score the center rod.

■ B□W type

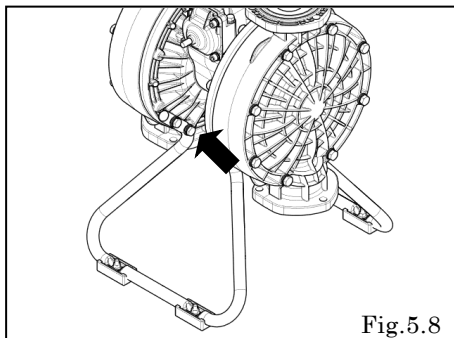

- For BPW & BVW, remove the 8 retainer bolts (4 bolts for NDP-40) to take out the stand body [Fig.5.8].

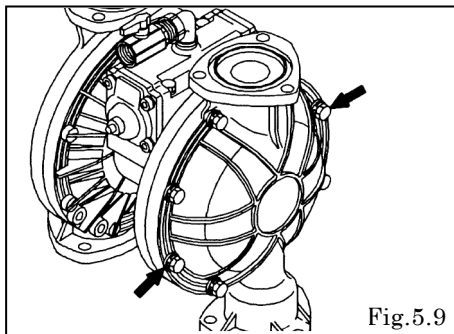

- Remove the balls and the valve seats (please refer to '4.1 Removal').
- Remove the 16 retainer bolts (24 bolts for NDP-80 and NDP-800) to take out the out-chambers. [Fig.5.9]

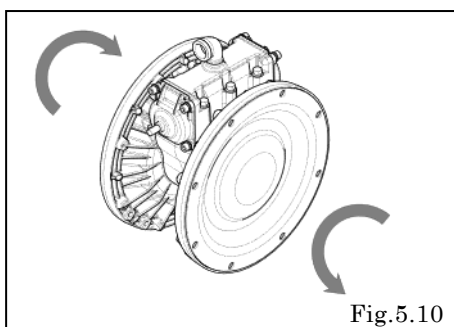

- Remove the diaphragms from both sides [Fig.5.10].
- When one of the diaphragms is removed, take out the center disk and cushion. Then remove the other diaphragm, the center disk, the cushion and the center rod from the main body. (NDP-80 and NDP-800 have no center disks and cushions).

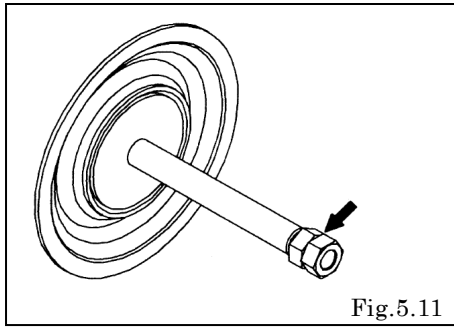

- Remove the other diaphragm by using a double nut, then take the diaphragm, the center disk and cushion out of the center rod [Fig.5.11].

<NOTE>

Be careful not to scratch or score the center rod.

5.2 Inspection

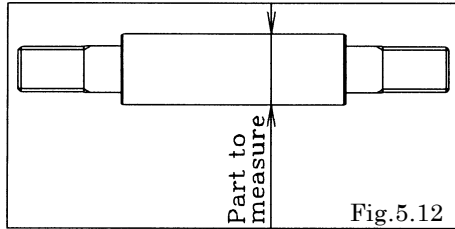

- Diaphragm

If the diaphragm is worn out or damaged, replace it. Never replace just one diaphragm.

Frequency of inspecting the diaphragms
(Transferring water at room temperature)

CR, NBR, EPDM	10,000,000 cycle
FKM	2,500,000 cycle
PTFE	3,000,000 cycle
TPEE, TPO	15,000,000 cycle
PTFE+EPDM	7,500,000 cycle

*The standard in our facility is 'Air supply pressure 0.5 MPa with no discharge pressure.

*It's recommended to conduct an inspection, if 3 months have passed since you start using the pump, or if the number of cycles reaches the above.

- Center rod [Fig.5.12]

If you find a scar on the sliding parts, please replace it for the new one.

Measure the diameter, and if it is outside the usable range, replace the rod.

Usable range of center rod

Ø 24.93 - Ø 25.00 mm

5.3 Installation

■ B□C, B□N, B□E, B□V, B□H, B□S, B□H/T types

For installation, see [Exploded View] on the separate sheet and install in the reverse order of disassembly.

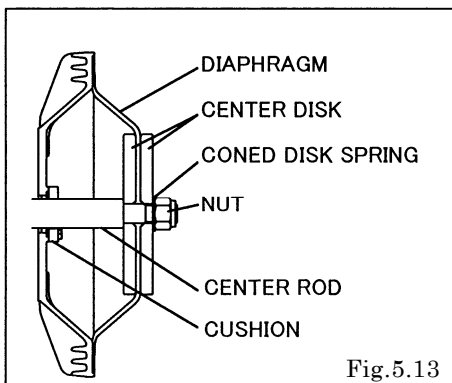

- Apply assembly grease to center rod, and insert it into the main body.
- Insert the cushion (except with the NDP-80 and NDP-800). (cf. Fig.5.13)
- Keep the marking "OUTSIDE" to liquid end for CR, NBR, EPDM, FKM diaphragms. Keep the convex side to the outside for TPEE, TPO diaphragms.
- Tighten the center disk using the Outer disk wrench (special tool: Part No.771868) for the BP□, BV□ types. Apply proper Thread locker to the thread of center disk. (No coned disk springs and nuts are needed.)
- For 500 type, apply proper Thread locker to the thread of center disk and then tighten the center disk. (No coned disk springs and nuts are needed.)

Tightening torque for center rod

BA□, BS□, BF□	60 N·m
BP□, BV□	50 N·m

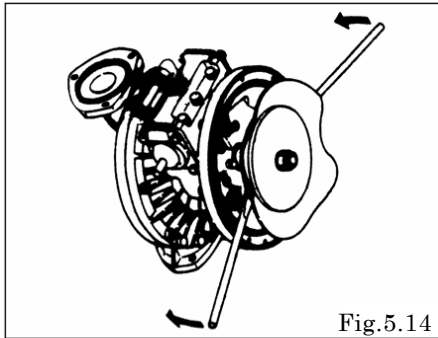

Fig. 5.14

- Draw the center disk to one side (exclude B□H, B□S, B□H/T type cf. Fig. 5.13). and install the out chamber. tighten the bolts temporarily.
- Grip the inside center disk using crowbars and draw it to the opposite side, then turn the diaphragm over. (exclude B□H, B□S, B□H/T type) [Fig. 5.14, 5.15]
- And install the out chamber. Tighten the bolts temporarily.
- After installation of the out chambers on both sides, place the pump on a flat surface and stand the pump upright for further assembly.

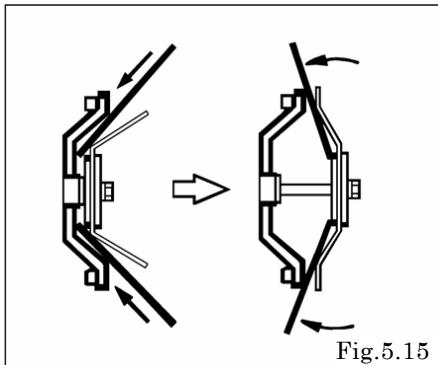

Fig. 5.15

Tightening torque for out chamber.

BA□, BS□, BF□	40 N·m
BP□, BV□	35 N·m

<NOTE>

- Make sure there is no dust on the seal surface in order to prevent seal damaged.
- Be careful not to damage the R portion of the air chamber using a crowbar, etc.
- Tighten the bolts gradually in a diagonal sequence with even torque. [Fig. 5.16].

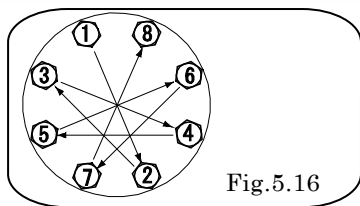

Fig. 5.16

■ B□T type

For installation, see [Exploded View] on the separate sheet and install in the reverse order of disassembly.

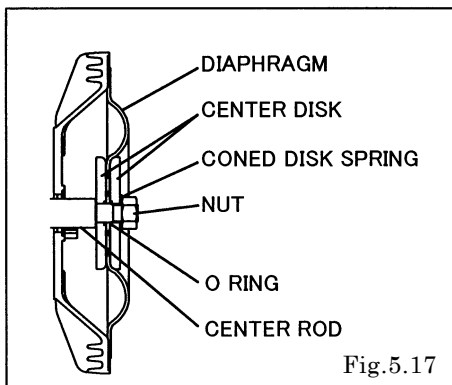

Fig. 5.17

- Apply assembly grease to center rod, and insert it into the main body.
- Keep the convex side to the outside (cf. Fig. 5.17).
- Put the O rings to both sides of the diaphragm. (cf. Fig. 5.17)
- Tighten the center disk using the Outer disk wrench (special tool: Part No. 771868) for the BPT, BVT type. Apply proper Thread locker to the thread of center disk. (No coned disk springs and nuts are needed.)

Tightening torque for center rod

BAT, BST, BFT	60 N·m
BPT, BVT	50 N·m

- Tighten the out chamber temporarily at first. After installation of the out chambers on both sides, place the pump on a flat surface and stand the pump upright for further assembly.

Tightening torque for out chamber

BAT, BST, BFT	40 N·m
BPT, BVT	35 N·m

<NOTE>

- Make sure there is no dust on the seal surface in order to prevent seal damaged.
- Replace the PTFE O ring by new one.
- Tighten the bolts gradually in a diagonal sequence with even torque. [Fig. 5.18].

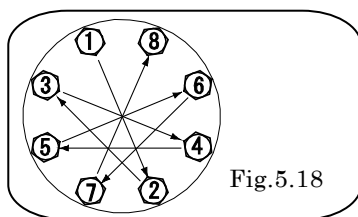
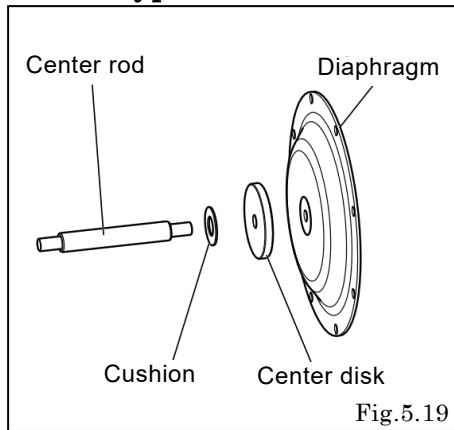

Fig. 5.18

■B□W type



- Install the cushion, the center disk, and then the diaphragm in this order to one side of the center rod (NDP-80 and NDP-800 have no center disk and cushion) [Fig.5.19].

<NOTE>

Tighten them by hand until they stop rotating.

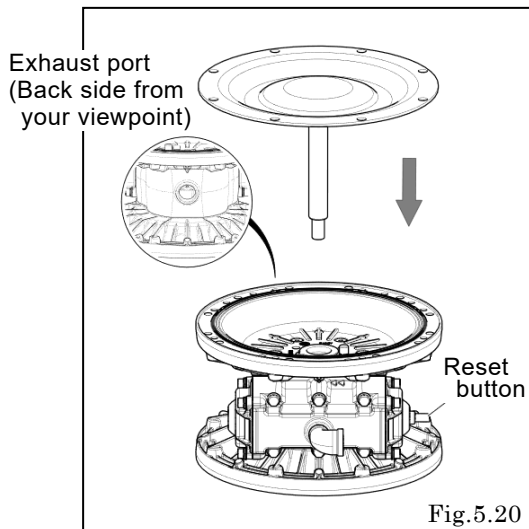

- Place the main body so that the exhaust port will be at the back side and the reset button will face to the right from your viewpoint.
- Apply grease to the center rod and the inside of the throat bearings before inserting the center rod into the main body [Fig.5.20].

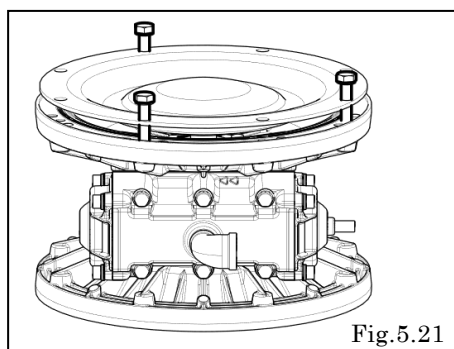

- Put three bolts through the holes on the diaphragm, and temporarily fasten them to the air-chamber [Fig.5.21].

<NOTE>

Those three bolts are to fix the positions of the holes on the air-chamber and the diaphragm. So tentatively tighten those bolts by rotating them by hand three to four times.

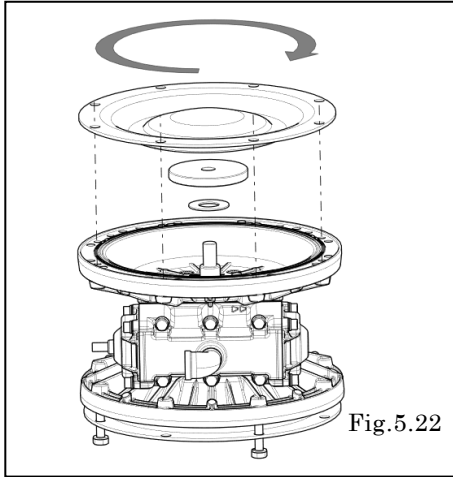

- Install the cushion, the center disk, and the diaphragm to the other side of the center rod (NDP-80 and NDP-800 have no center disk and cushions).
- Rotate the diaphragm clockwise by hand until it's tightened [Fig.5.22].

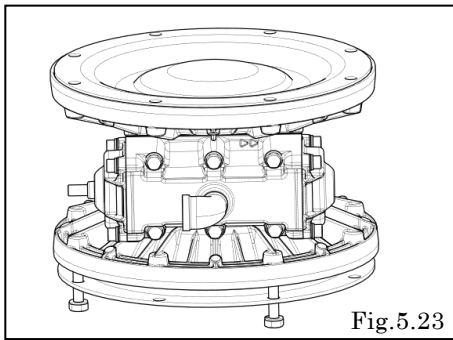

- When tightening the diaphragm at Fig. 5.20, the holes on the diaphragm should be at the same positions as the 8 (12 on the NDP-80 and NDP-800) screw holes on the air-chamber. Basically, those hole positions should be adjusted by rotating the diaphragm clockwise. If it is difficult, move the diaphragm counter-clockwise a little bit to adjust them [Fig.5.23]

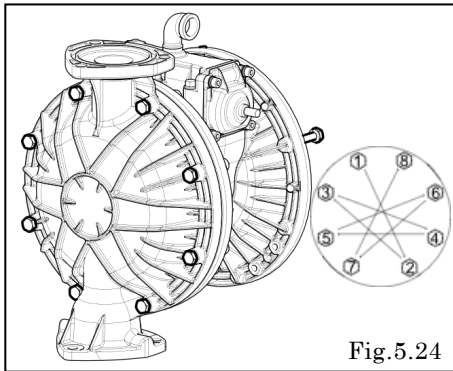

- Install the out-chamber to the side where the diaphragm has been put on, as mentioned in the above Fig.5.23. [Fig.5.24].



Tightening torque for out chamber

BA□, BS□, BF□	40 N·m
BP□, BV□	35 N·m

<NOTE>

- Fig.5.24 shows the standard positions of the out-chambers and the valve body assembly. But those positions can be freely changed, depending on how and where the pump will be installed.
- Tighten the bolts gradually in a diagonal sequence with even torque.

⚠ CAUTION

- 
 - Be careful not to get your finger stuck between the diaphragm and the out-chamber.
- 
 - Connect the air hose after confirming that the air valve and the air regulator are closed. The diaphragms will suddenly move when the air is suddenly supplied, which will cause serious injury.
- 
 - Try supplying the air with the pressure 0.1 MPa. If the diaphragm doesn't work, stop the air supply and check if there is anything wrong with how the pump is assembled.

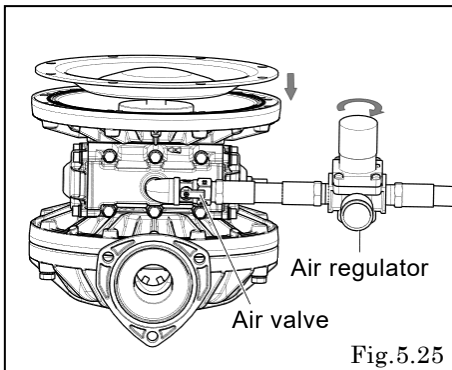

- Remove the bolts that were temporarily fastened at Fig. 5.21.
- Install the silencer to the exhaust port, and the air valve and regulator to the air supply port.
- Press the reset button and open the air valve.
- When gradually opening the air regulator and supplying the air with the pressure 0.1 MPa maximum, the diaphragm will move slowly. Adjust the regulator pressure to maintain the position of the diaphragm, so that the gap between the diaphragm and the main body will be minimal. [Fig. 5.25].

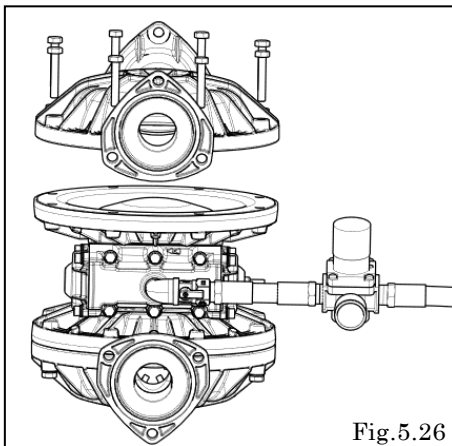

- Install the other out-chamber with the air being supplied [Fig. 5.26].

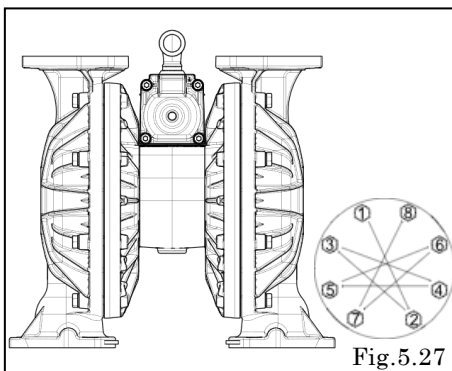

- Tighten the bolts by hand. Close the air regulator and air valve. Then remove the silencer.
- Ensure that the out-chambers on both sides are aligned parallel to each other. Adjust them if not.
- Tighten the bolts on the out-chambers (please refer to the previous chapter 'Tightening torque for out-chambers' [Fig. 5.27]).

<NOTE>

Tighten the bolts gradually in a diagonal sequence with even torque.

6. Throat bearing and Pilot valve assembly

6.1 Removal

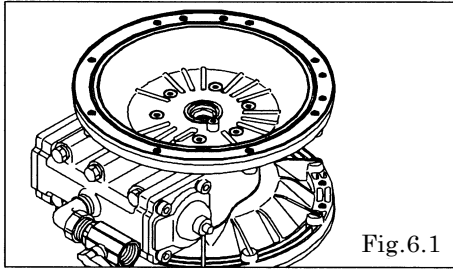

- Remove the diaphragm and center rod (see “5.1 Removal”).
- Remove the 12 retainer bolts from the air chamber, and remove the air chamber. [Fig.6.1]

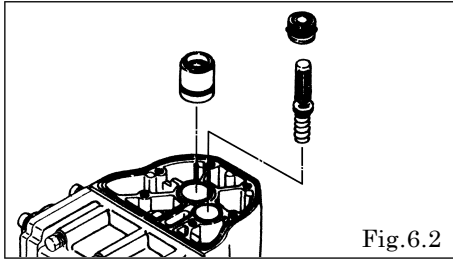

- Draw out the pilot valve, spring and valve seat. [Fig.6.2]
- Draw out the throat bearing. [Fig.6.2]

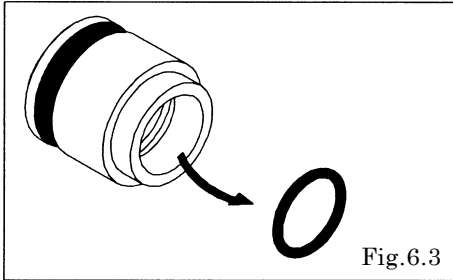

- Remove the packing from the throat bearing. [Fig.6.3]

6.2 Inspection

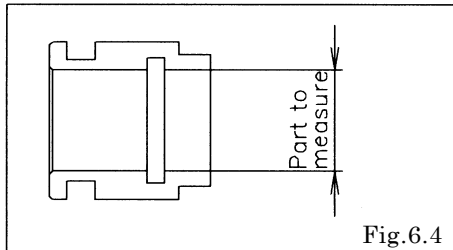

- Throat bearing [Fig.6.4]
Measure the inside diameter, and if it is outside the usable range, replace the throat bearing

Usable range of throat bearing

Ø 25.04 - Ø 25.15 mm

- O ring, Packing
If the O ring is worn out or cracked, replace it.
- Pilot valve
If the pilot valve is worn out or cracked, replace it.

6.3 Installation

For installation, see [Exploded View] on the separate sheet and install in the reverse order of disassembly.

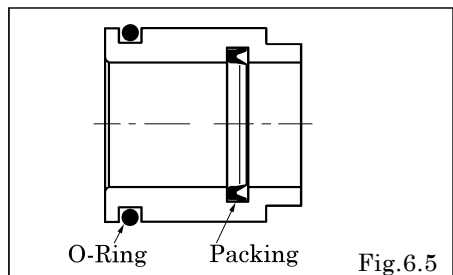

Tightening torque for air chamber retainer bolts

20 N·m

<NOTE>

- Make sure there is no dust on the seal surface and the seal is not damaged.
- Apply grease to packing.

7. C spool valve assembly

7.1 Removal

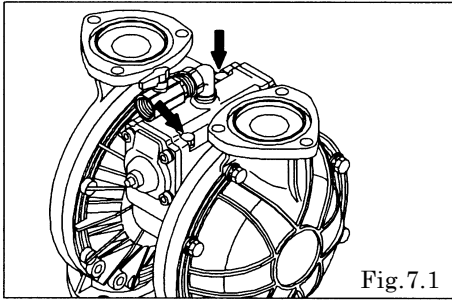

- Remove the out manifold (see “4.1 Removal”).
- Remove the 6 retainer bolts from the valve body, and remove the valve body. [Fig. 7.1]

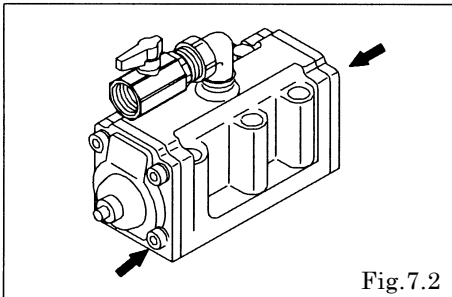

- Remove the 8 cap A and cap B retainer bolts, and remove cap A and cap B. [Fig. 7.2]

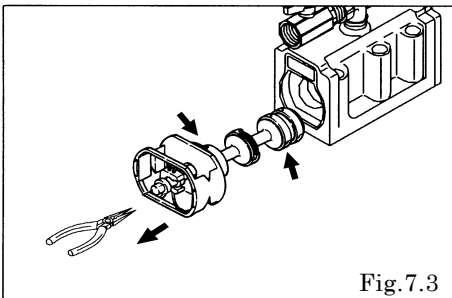

- Draw out the C spool valve assembly using the plyer, and remove the seal ring from the C spool valve assembly.
- Remove the spring stopper. [Fig. 7.3]

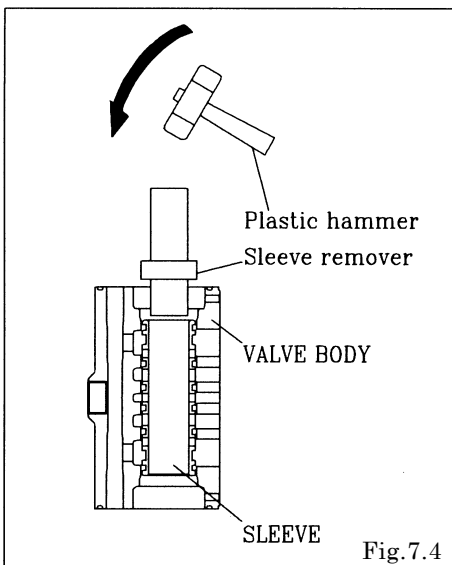

- Remove the sleeve using the sleeve remover (special tool: Part number 713180). [Fig. 7.4]

7.2 Inspection

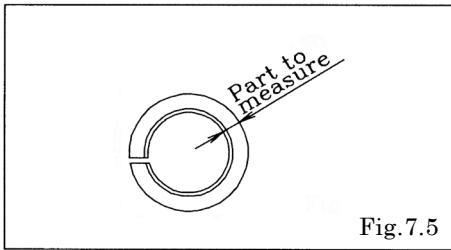

Fig.7.5

- C Spool Valve Assembly

- Seal ring [Fig.7.5]

Measure the inside thick diameter, and if it is outside the usable range, replace the C Spool Valve Assembly. If the seal ring is worn out or cracked, replace C Spool Valve Assembly.

Usable range of Seal ring

3.77 - 3.85 mm

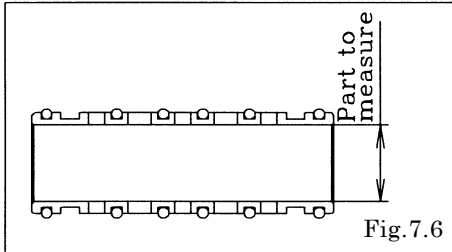

Fig.7.6

- Sleeve Assembly [Fig.7.6]

If you find a scar, replace it for the new one. Measure the inside diameter, and if it is outside the usable range, replace the c spool valve assembly.

Usable range of sleeve

Ø 33.15 - Ø 33.35 mm

- O ring

If the O ring is worn out or cracked, replace it.

<NOTE>

- C Spool Valve Assembly must be replaced as a complete set. Unable to replace individual component.

7.3 Installation

For installation, see [Exploded View] on the separate sheet and install in the reverse order of disassembly.

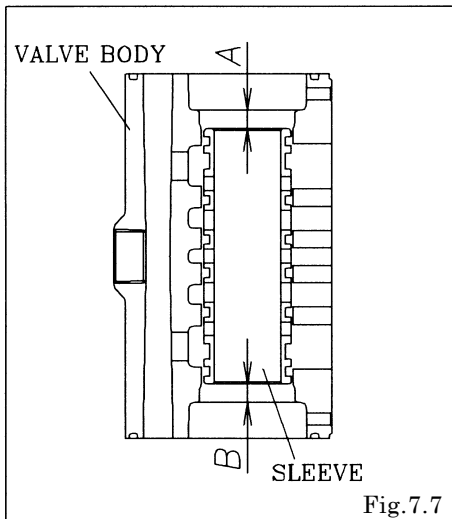

Fig.7.7

- Install the sleeve using the sleeve remover (special tool: Part No. 713180). At this point, apply assembly oil around the sleeve and O ring.
- Install the sleeve at the center of the valve body. (A = B)

Tightening torque for installation cap A, cap B

10 N·m

Tightening torque for valve body installation bolts

17 N·m

<NOTE>

- Make sure there is no dust on the seal surface and it is not damaged.

8. Retightening of Tie rods

■ Metal type

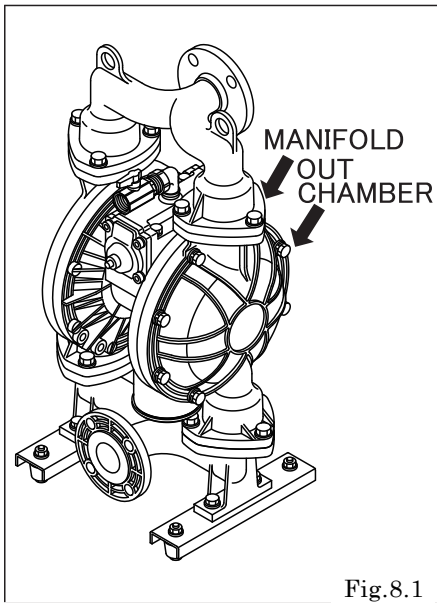

- All bolts should be retorqued:
 - (1) Right before start up.
 - (2) There are any leaks of material on daily inspecting a pump.

		Retain bolts for the out chamber.	Retain bolts for the manifold.
NDP-40	BA□	40 N·m	25 N·m
NDP-50	BS□		
NDP-80	BF□		
NDP-800	BF□		
NDP-500	BS□	40 N·m	20 N·m

<NOTE>

- Retighten the Out chamber and then the manifold in this order. [Fig.8.1]
- Tighten the bolts in the order shown. [Fig.8.2]

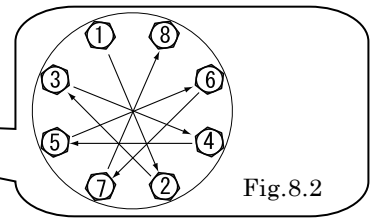

■ Plastic type

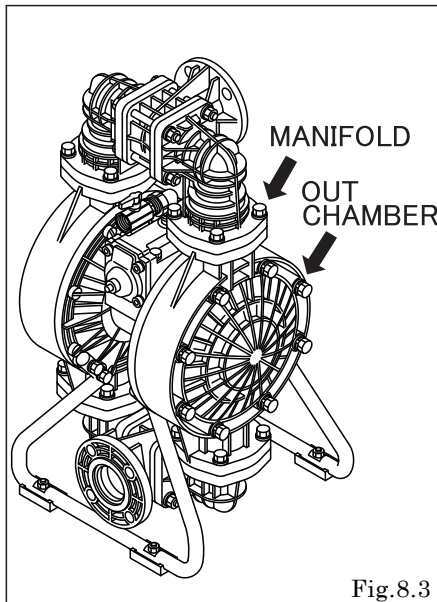

- All bolts should be retorqued:
 - (1) Right before start up.
 - (2) There are any leaks of material on daily inspecting a pump.

		Retain bolts for the out chamber.	Retain bolts for the manifold.
NDP-40	BP□	35 N·m	20 N·m
NDP-50			
NDP-80			
NDP-40	BV□		
NDP-50			

<NOTE>

- Retighten the Out chamber and then the manifold in this order. [Fig.8.3]
- Tighten the bolts in the order shown. [Fig.8.4]

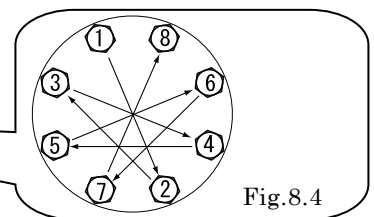

YAMADA CORPORATION

International Sales Department

1-1-3, Minami-Magome, Ota ku, Tokyo, 143-8504, Japan

PHONE : +81-(0)3-3777-0241

FAX : +81-(0)3-3777-0584

E-mail : intl@yamadacorp.co.jp

Web : www.yamadacorp.co.jp

YAMADA (THAILAND) CO., LTD

41/79 Moo 6, Bangcha-long, Bangplee, Sumutprakarn 10540, Thailand

PHONE : +66-(0)2-130-0990

FAX : +66-(0)2-130-0993

E-mail : sales@yamada-th.com