

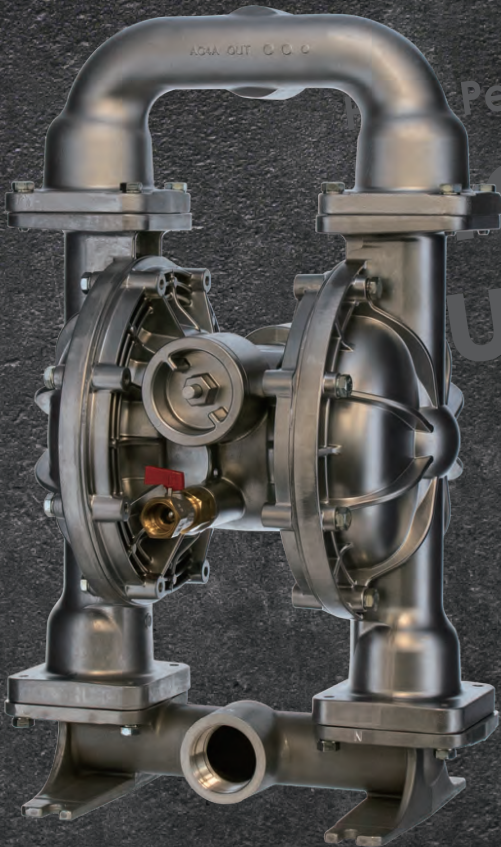

GLOBAL SERIES

Air-Powered Double Diaphragm Pumps



High Performance Air Operated
Diaphragm
Pumps



High Performance Air Operated
Diaphragm
Pumps

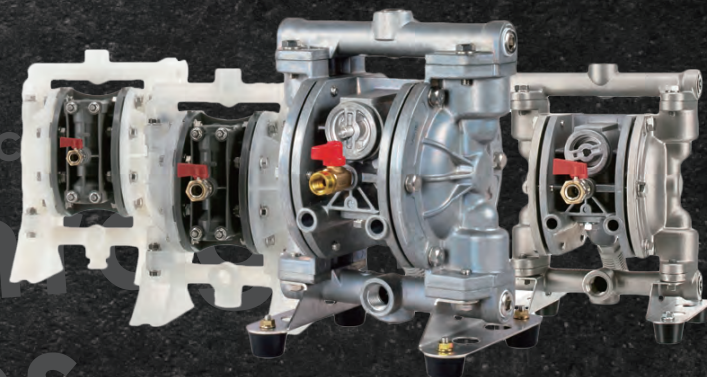

High Performance
Diaphragm
Pumps

Yamada Advantages

The Yamada Corporation has been a leading producer of industrial equipment since 1905, and of fluid handling products for over 65 years. As a leader in pneumatic pumping technology, Yamada is known in many industries worldwide for its innovative products, superior quality, and unmatched reliability. An impressive history of product design and engineered solutions establishes Yamada as forerunner in industrial pump technology.

Yamada's reputation for manufacturing top quality products, allied with continuing efforts in research and development, have created a strong foundation for market leadership. As an ISO 9001 certified corporation, stringent quality procedures are followed throughout the manufacturing process, including assembly procedures and product testing.

The Yamada Corporation is headquartered in **Tokyo** with manufacturing facilities located throughout Japan. Production facilities are located in **Arlington Heights, Illinois, USA**, servicing the Western Hemisphere; **The Netherlands**, providing support throughout Europe, Africa, and the Middle East; **Thailand**, covering the Southeast Asia; and **Shanghai**, covering the emerging Asian market. These offices are support centers for over 400 authorized fully stocking Yamada distributors worldwide.

Advantages and Characteristics

1. **Handle a wide variety of fluids with high solids content:** No close fitting or rotating parts so liquid with high solids content and/or particle size can be easily pumped.
2. **Self Priming:** The Yamada pump design (incorporating internal check valves) provides high suction lift even at dry start-up and with heavier fluids.
3. **Ability to run dry:** No close fitting or sliding parts are at risk—the pump can run dry without damage.
4. **Variable flow rate and discharge pressure:** Yamada pumps will run at any setting within their operating range simply by adjusting the air inlet pressure and system conditions. One pump can fit a broad spectrum of applications.
5. **Portable/Simple Installation:** Yamada pumps transport easily to the application site. Simply connect an air supply, attach fluid connections, and the pump is ready to perform. There are no complex controls to install or operate.
6. **Dead Head:** The discharge line can be closed with no damage or wear. The pump will simply slow down and stop.
7. **Shear sensitive:** The gentle nature and minimal parts contact with the liquid make Yamada pumps an excellent choice for shear sensitive fluids.
8. **Safe Operation:** Powered by compressed air, Yamada pumps are intrinsically safe.
9. **Submersible:** If external components are compatible, Yamada pumps can be submerged in liquids by simply running the exhaust line above the liquid level.
10. **Pumping efficiency remains constant:** There are no rotors, gears, or pistons, which wear over time and lead to the gradual decline in performance/flow rate.

For additional information on Yamada products and services, visit ap.yamadacorp.co.jp

Air-Operated Diaphragm Pump

Our Global Series was created to bring Yamada's time-tested and trusted technology to customers across the globe. Together with the Yamada field proven and trusted NDP Series, the Global Series expands the potential of Yamada's AODD pumps even further.

Air Switch Valve Technology

Yamada air switch valve technology is the heart of the air-powered double diaphragm pump and determines reliability.

S-Spool

● S-Spool (Step Spool) + New Center Rod to Prevent Stoppages during Operation

Minimizes the risk of stoppages, even during low-stroke operations.

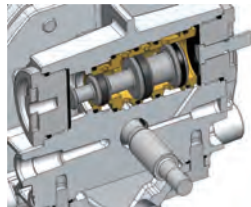

● Equipped with a Reset Button

Keep downtime to a minimum in the unlikely event of pump stoppage caused by air switch valve wear. (for metal body pumps only)



● Designed to Operate without Pilot Valve

Fewer parts means fewer potential points of failure.



● Oil Free

Does not require regular lubrication.

C-Spool

● C-shaped Spring to Prevent Stoppages during Operation

Ensures stable operation.



● Equipped with a Reset Button

Keep downtime to a minimum in the unlikely event of pump stoppage caused by air switch valve wear.



● Oil Free

Both the air switch valve and the pilot valve, which activates the air switch valve when the stroke limit is reached, feature an oil-free design. Does not require regular lubrication.

● Simple Replacements

There is no need to disassemble the pump when replacing it.



How to Determine the Model Type

G 15   00

1 Series Initial

2 Pump Size (Diameter)

- 15 1/2" (15 mm)
- 25 1" (25 mm)
- 50 2" (50 mm)

3 Wetted Parts Material of Main Body

- Ⓐ Aluminum (ADC12)
- Ⓔ Stainless steel (SCS14)
- Ⓟ Polypropylene (PP)
- Ⓥ Kynar® (PVDF)

4 Materials of Diaphragm, etc.

- Ⓝ Buna N (NBR)
- Ⓣ PTFE
- Ⓜ Hytrel® (TPEE)
- Ⓢ Santoprene® (TPO)

G15 Series

62L/min Maximum Flow Rate
1/2 inch Port Size

Metal Body Pumps



G15A□

Plastic Body Pumps



G15P□

FEATURES & BENEFITS

- Truly non-lubricated
- Stall-Free / S-Spool design
- Multiple port manifold
- Fewer wearing parts
- Ease of Repair - Quick teardown and Rebuild
- 30% less air consumption over competitor's pumps
- Critical reliability for On/Off cycling
- No pilot valve

APPLICATIONS:



Specifications



Port Size		1/2" (15A)
Liquid	Intake	Rc1/2 or NPT1/2
	Discharge	
Air	Supply	Rc1/4 or NPT1/4 includes ball valve
	Exhaust	Rc3/8 or NPT3/8 with silencer
Air Supply Pressure		0.2-0.7MPa
Maximum Discharge Pressure		0.7MPa
Discharge Volume Per Cycle		G15AN: 170mL, G15A□: 160mL G15S□: 150 mL, G15P□/G15V□: 190mL
Maximum Size Solid		1mm
Net Weight		G15A□: 5.4kg G15S□: 8.2kg G15P□: 2.6kg G15V□: 3.5kg
Body Material		Aluminum, Stainless Steel, Polypropylene, Kynar®
Diaphragm Material		Buna N, Santoprene®, Hytrel®, PTFE

Liquid temperature-pressure correlation chart

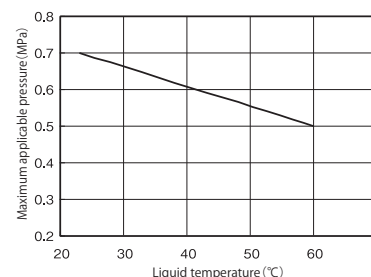

Plastic Body Pumps:

Air supply pressure of Plastic Body Pumps is depending on the liquid temperature. Be sure to check the Liquid temperature – Pressure Correlation Chart.



G15V□:

Purchaser shall not directly or indirectly, export, re-export transship or otherwise transfer this product in violation of any applicable export control laws and regulations promulgated and administered by the governments of the countries asserting jurisdiction over the parties or transaction.

Dimensions and Performance Curve

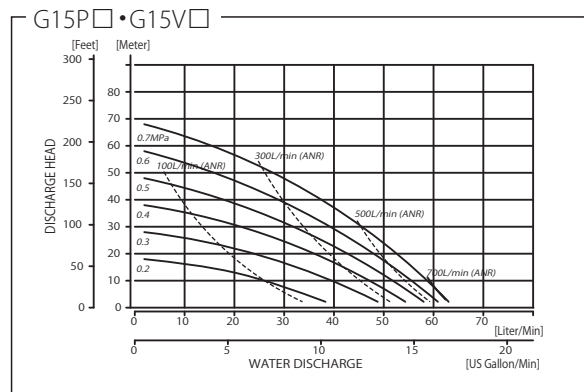
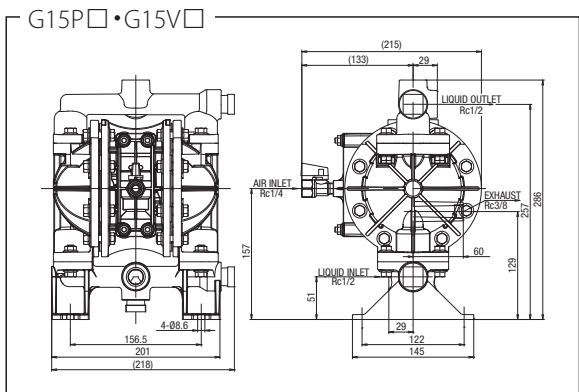
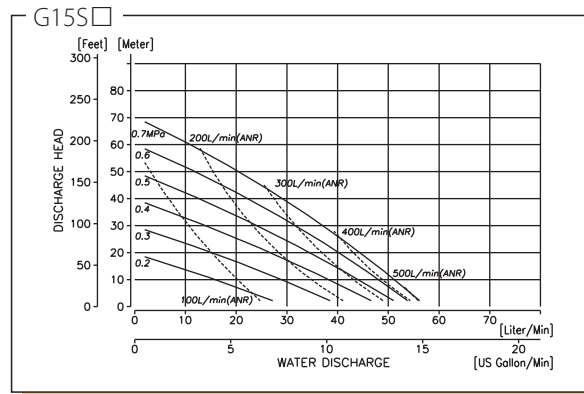
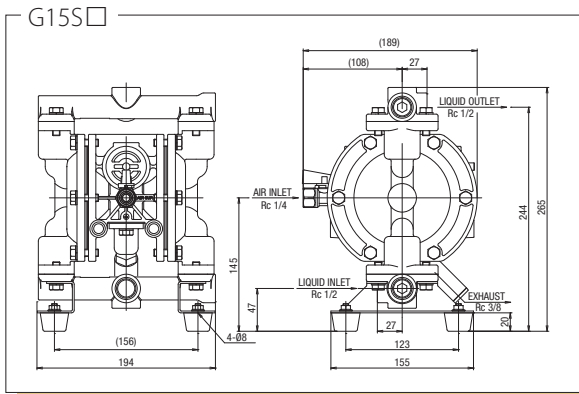
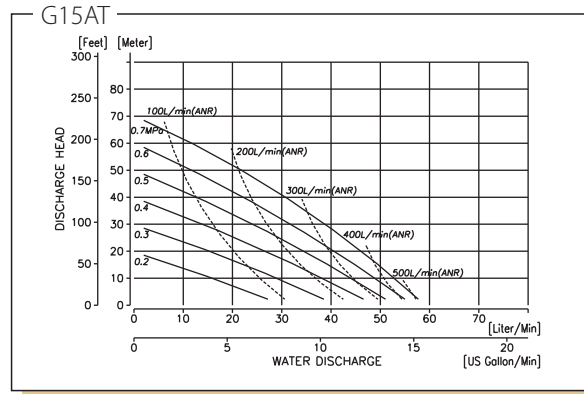
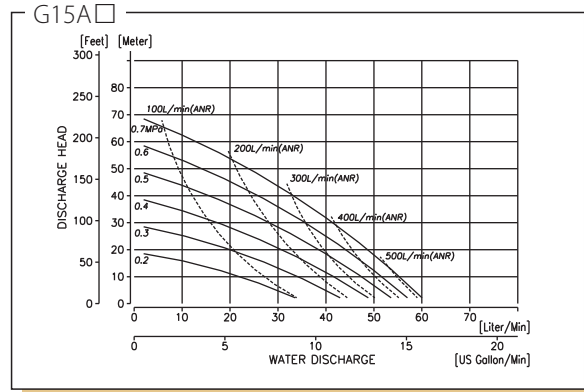
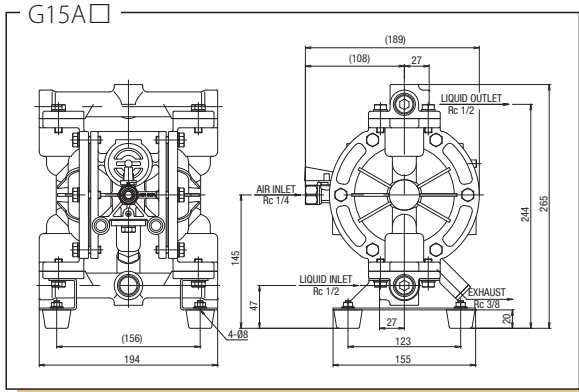

G25 Series

150L/min Maximum Flow Rate
1 inch Port Size

Metal Body Pumps

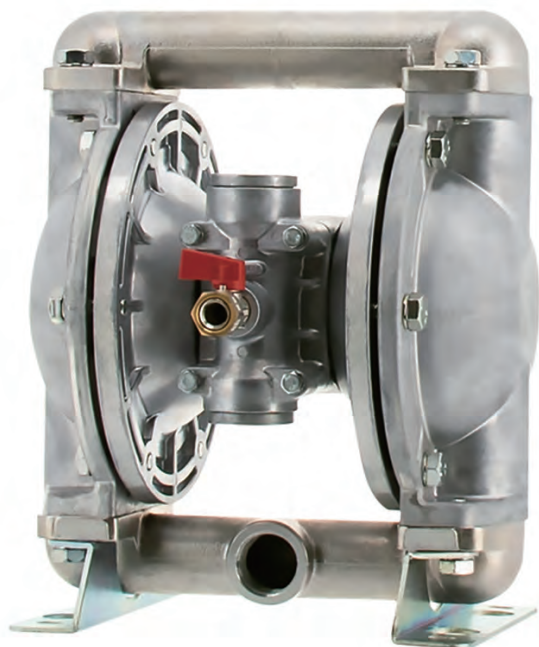

G25A□

FEATURES & BENEFITS

- Truly non-lubricated
- Stall-Free / S-Spool design
- Fewer wearing parts
- Ease of Repair - Quick teardown and Rebuild
- 20% less air consumption over competitor's pumps
- Piping interchangeability with leading brands

APPLICATIONS:

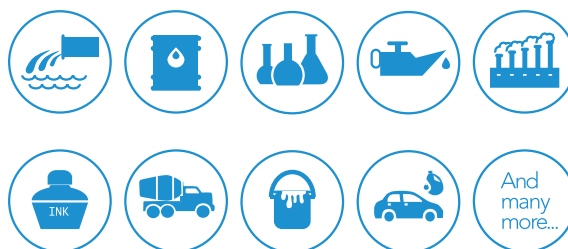

Specifications



Port Size		1" (25A)
Liquid	Intake	Rc1 or NPT1
	Discharge	
Air	Supply	Rc3/8 or NPT3/8 includes ball valve
	Exhaust	Rc3/4 or NPT3/4 with silencer
Air Supply Pressure		0.2-0.7MPa
Maximum Discharge Pressure		0.7MPa
Discharge Volume Per Cycle		G25A□: 600mL G25A□: 450mL
Maximum Size Solid		3mm
Net Weight		9.2kg
Body Material		Aluminum
Diaphragm Material		Buna N, Hytrel®, Santoprene®, PTFE

Dimensions and Performance Curve

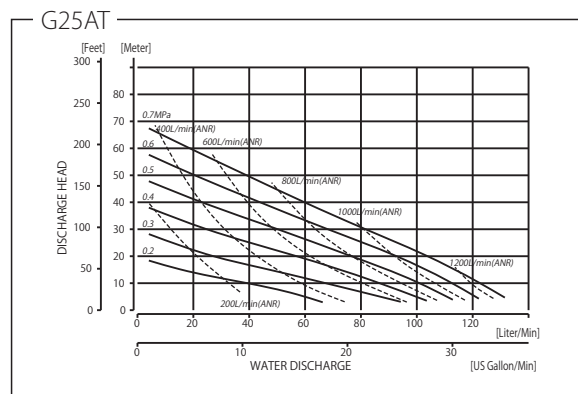
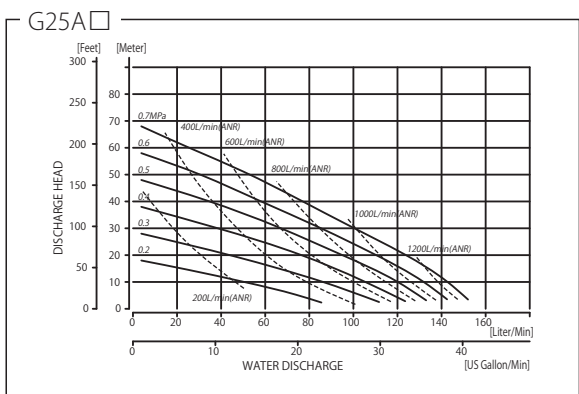
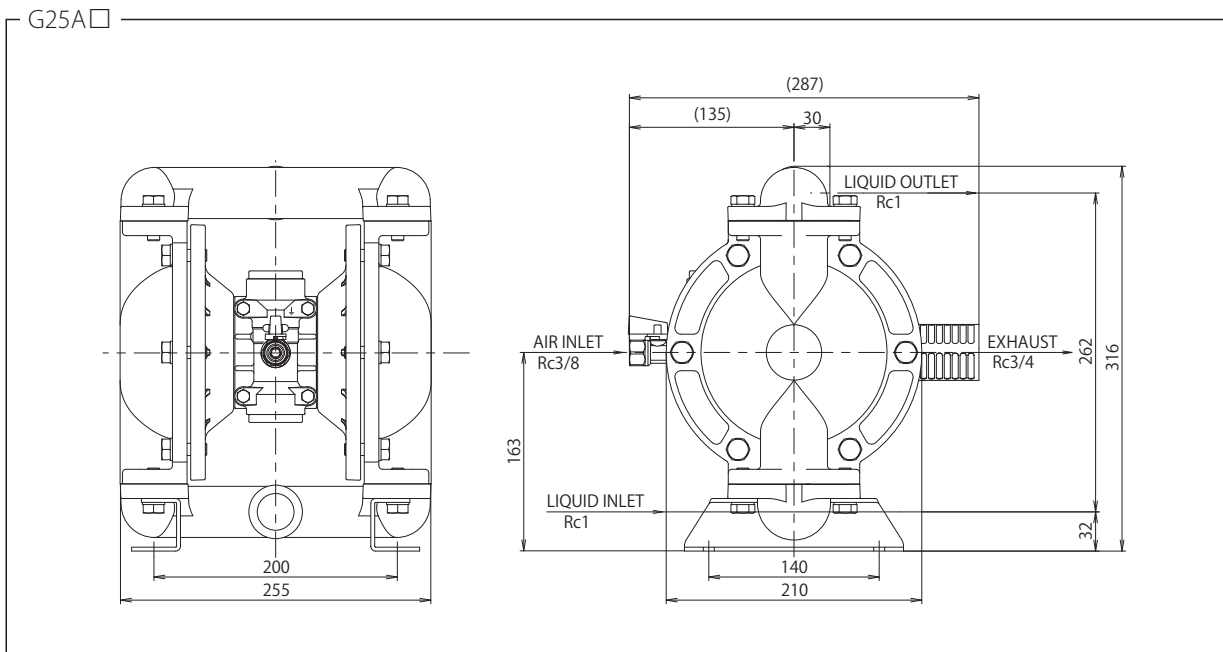

G50 Series

670L/min Maximum Flow Rate
2 inch Port Size

Metal Body Pumps

New!



G50A □

FEATURES & BENEFITS

- Piping interchangeability with leading brands
- The lightest 2" aluminum pump among competitive brands.
- The field proven C Spool technology borrowed from the NDP series
- Truly non-lubricated
- The fewest total parts and the least number of wearing parts
- Ease of Repair - Quick teardown and Rebuild

APPLICATIONS:

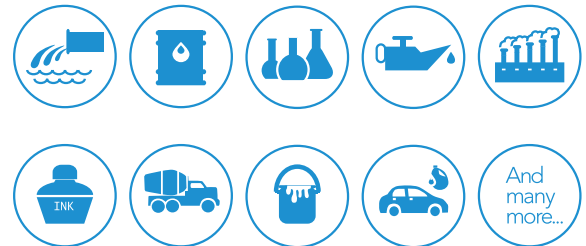

Specifications



Port Size		2" (50A)
Liquid	Intake	Rc2 or NPT2
	Discharge	
Air	Supply	Rc3/4 or NPT3/4
	Exhaust	Rc1 or NPT1
Air Supply Pressure		0.2-0.7MPa
Maximum Discharge Pressure		0.7MPa
Discharge Volume Per Cycle		2.4L
Maximum Size Solid		8mm
Net Weight		G50AN: 29kg G50AT: 30kg
Body Material		Aluminum
Diaphragm Material		Buna N, Hytrel®, Santoprene®, PTFE

Dimensions and Performance Curve

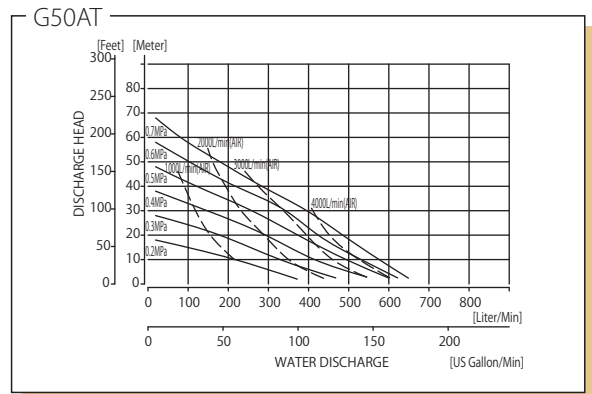
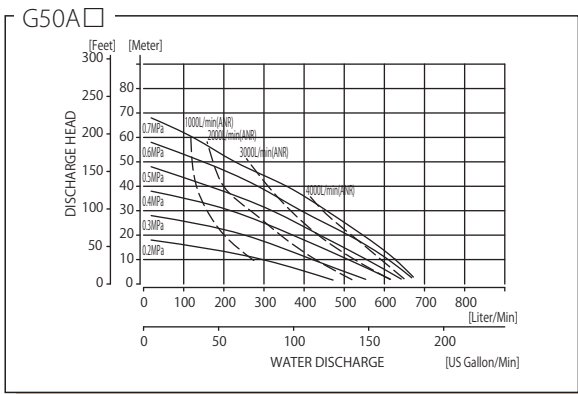
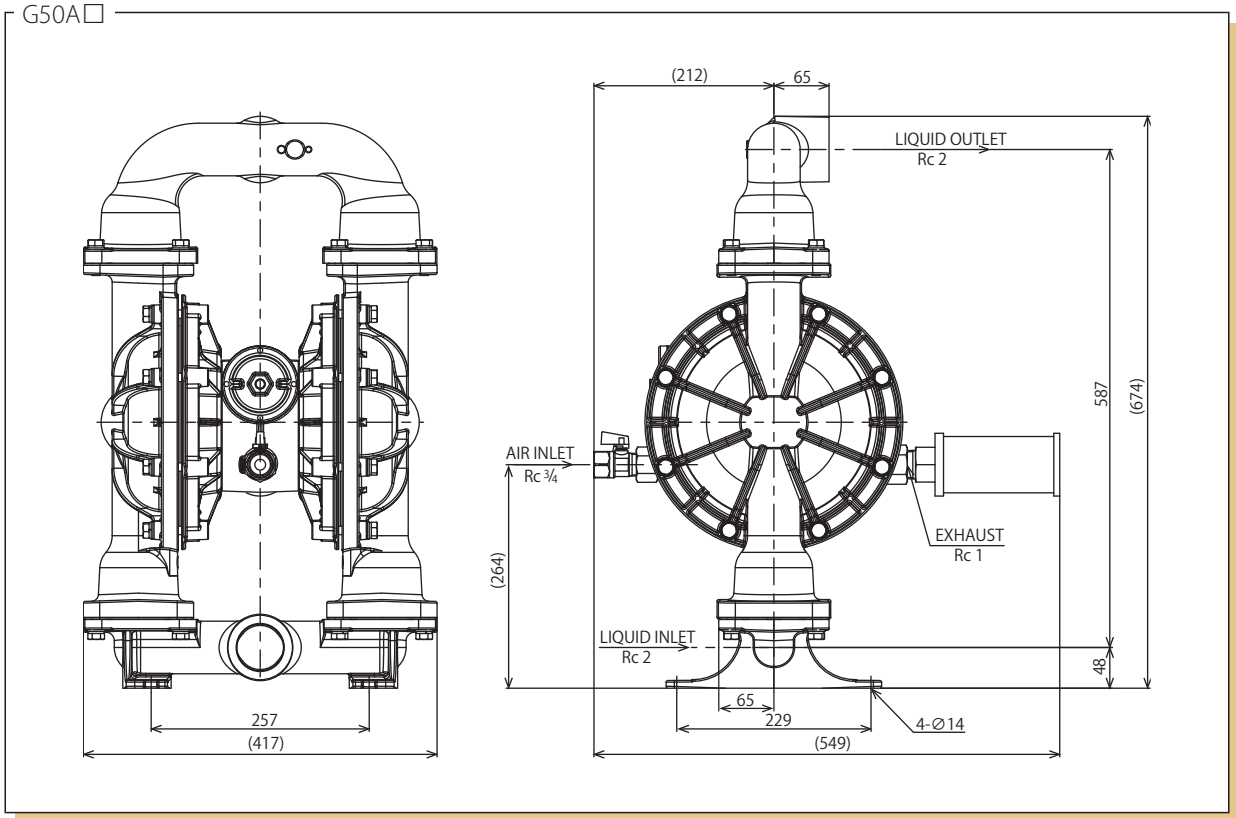

Accessories

Repair Parts Kit

Yamada offers complete repair parts kits for Global Series pumps.

- Air Side Kit and Liquid side Kit are available.
- Repair parts kit contains exactly what you need.
- You can save your time finding the necessary individual parts and avoid order errors.



Air Side Kit



Liquid Side Kit

Understanding Performance Curves

Understanding how to read a pump curve chart will help choose the right pump for a specific application.

Using Performance Curves

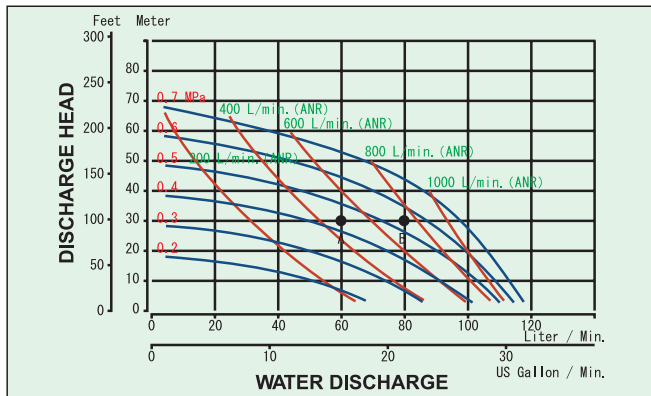

Precautions for pump selection

- * Select a pump with safety margin (1.5 times or higher) appropriate for the required conditions with taking effective use of a diaphragm and other expendables into consideration.
 - * The performance curve shown on the right indicates the data measured with fresh water (viscosity 1 mPa·s, specific gravity 1.0) by dip grazing with the shown devices. The amount of liquid discharged from the pump greatly varies depending on various factors such as the "viscosity, specific gravity and slurry concentration of liquid to be transferred," "suction lift," "discharge head" and "pneumatic transportation distance." If you are not sure which pump you should select, fill in the selection criterion of the "Inquiry Sheet" on the end of the document as much as possible, and contact us.
1. The solid lines plot the relation between the amount of the discharged liquid ("water discharge") and the discharge head when the corresponding pressure is given. First, decide which curve corresponds to the desired air pressure.
 2. For example, when the supplied air pressure at your site is 0.5 MPa, check the curve marked "0.5 MPa."
 3. When liquid to be transferred is fresh water (viscosity is 1 mPa·s and specific gravity is 1.0), the desired water discharge is 60 L/min, and the discharge head is 30 m, the corresponding axes intersect at Point A. This point is located below the 0.5-Mpa curve and satisfies the desired water discharge and discharge head with this pump (Example: NDP-20).
 4. If it is required that "the water discharge is 80 L/min, and the discharge head is 30 m," the intersection point is "B" above the 0.5-MPa curve and this indicates that this pump cannot satisfy your conditions. In such a case, we recommend that you select the larger one (NDP-25). With a suction lift of 12-ft, 4m pump rate decreases by approximately 20%. Valid for pumps 3/4" and larger; data varies with pump configuration.

Specified Suction Lift

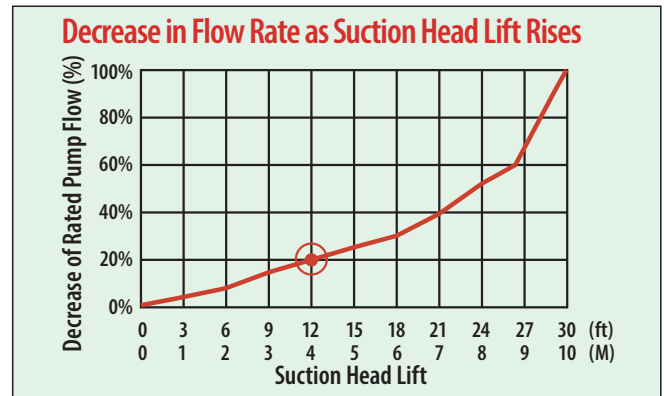

Viscous Liquids Performance Data

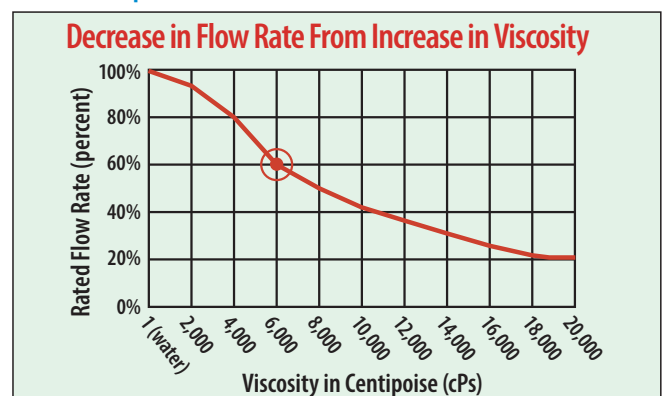

During the conveyance of a fluid with a viscosity of 6000 cPs, the pump rate decreases to 60% of its rated value (100% = water). Valid for 3/4" pumps & larger. Note: Please consult Yamada when both the pressure and temperature exceed 70 MPa and 180°C, respectively.

5. The dashed lines plot curves for air consumption as shown in the graph respectively. The point A, intersection point as a result of the condition "3" above (water discharge: 60 L/min, discharge head: 30 m) is located about in the middle between the 400L/min air consumption curve and the 600L/min air consumption curve. Therefore, the air consumption under this condition is approximately 500 L/min (ANR). Since the air consumption is calculated by converting to the barometric pressure, it does not vary depending on the used air pressure.

Corrosion Resistant Chart

Diaphragm Material		N: Buna N (NBR)	T: Teflon® (PTFE)	H: Hytrel® (TPEE)	S: Santoprene® (TPO)
Body Material	A: Aluminum (ADC12, AC4C-T6)	Lubricant, Kerosene, Wax, Cutting oil	Latex, Paint, Ink	Lubricant, heavy oil, brake oil, naphtha, kerosene, mold lubricant	Acetone, Bilge waste water
	S: Stainless steel (SCS14, SUS316)	L.P.G, Ethyl chloride, Sodium peroxide	Sulfuric acid (98%), Nitric acid (less than 25%), MEK, Acetone		
	P: Polypropylene (PP)	Whiskey, Sodium silicate, Methyl alcohol	Plating solution, Photograph developing liquid, Benzene, Hydrogen peroxide		
	V:Kynar® (PVDF)		Sodium hypochlorite		

✓ This table is for reference only, and the accuracy of the information it contains is not guaranteed. Pump model selection should be carried out by the end user based on operating conditions such as liquid concentration, temperature, and other factors, as well as information issued by the chemical manufacturer.

Installation Diagram

Ideal Installation for Air-Operated Double Diaphragm Pump

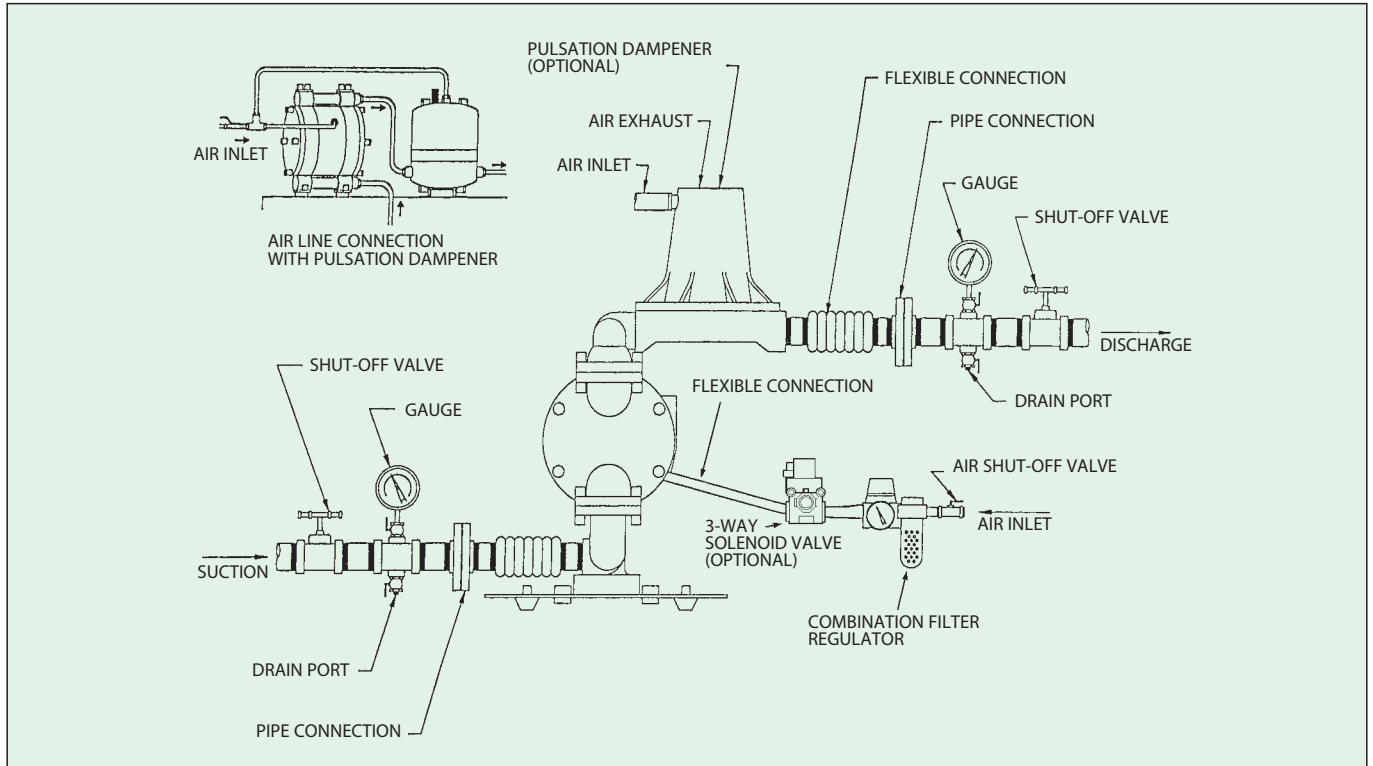



CAUTION WHEN SELECTING A PUMP

Yamada offers a large range of Air Operated Pumps to cater for many different kinds of materials and conditions. When selecting the most appropriate pump for a particular selection and installation please consult your local Yamada Pump Distributor or Yamada Corporation.

Your Local Distributor:

All product specifications and data are subject to change without notice.

Revised: Dec. 2024

YAMADA CORPORATION

International Sales Department

No.1-3, 1-Chome, Minami-Magome,
Ohta-ku, Tokyo 143-8504, Japan

Phone +81-(0)3-3777-0241

Fax +81-(0)3-3777-0584

E-mail: intl@yamadacorp.co.jp

Web: <https://ap.yamadacorp.co.jp/>