

High Performance Air Operated  
**Diaphragm Pumps**



# Yamada Advantages

**The Yamada Corporation** has been a leading producer of industrial equipment since 1905, and of fluid handling products for over 65 years. As a leader in pneumatic pumping technology, Yamada is known in many industries worldwide for its innovative products, superior quality, and unmatched reliability. An impressive history of product design and engineered solutions establishes Yamada as forerunner in industrial pump technology.

Yamada's reputation for manufacturing top quality products, allied with continuing efforts in research and development, have created a strong foundation for market leadership. As an ISO 9001 certified corporation, stringent quality procedures are followed throughout the manufacturing process, including assembly procedures and product testing.

The Yamada Corporation is headquartered in **Tokyo** with manufacturing facilities located throughout Japan. Production facilities are located in **Arlington Heights, Illinois, USA**, servicing the Western Hemisphere; **The Netherlands**, providing support throughout Europe, Africa, and the Middle East; **Thailand**, covering the Southeast Asia; and **Shanghai**, covering the emerging Asian market. These offices are support centers for over 400 authorized fully stocking Yamada distributors worldwide.

## Advantages and Characteristics

1. **Handle a wide variety of fluids with high solids content:** No close fitting or rotating parts so liquid with high solids content and/or particle size can be easily pumped.
2. **Self Priming:** The Yamada pump design (incorporating internal check valves) provides high suction lift even at dry start-up and with heavier fluids.
3. **Ability to run dry:** No close fitting or sliding parts are at risk—the pump can run dry without damage.
4. **Variable flow rate and discharge pressure:** Yamada pumps will run at any setting within their operating range simply by adjusting the air inlet pressure and system conditions. One pump can fit a broad spectrum of applications.
5. **Portable/Simple Installation:** Yamada pumps transport easily to the application site. Simply connect an air supply, attach fluid connections, and the pump is ready to perform. There are no complex controls to install or operate.
6. **Dead Head:** The discharge line can be closed with no damage or wear. The pump will simply slow down and stop.
7. **Shear sensitive:** The gentle nature and minimal parts contact with the liquid make Yamada pumps an excellent choice for shear sensitive fluids.
8. **Safe Operation:** Powered by compressed air, Yamada pumps are intrinsically safe.
9. **Submersible:** If external components are compatible, Yamada pumps can be submerged in liquids by simply running the exhaust line above the liquid level.
10. **Pumping efficiency remains constant:** There are no rotors, gears, or pistons, which wear over time and lead to the gradual decline in performance/flow rate.

For additional information on Yamada products and services, visit [ap.yamadacorp.co.jp](http://ap.yamadacorp.co.jp)



## CONTENTS

Model Indicator .....	5
Fair Guideline of Pump size and Flow rate. .6	
NDP-5 Series .....	7
DP-10 Series.....	9
NDP-15 Series .....	11
NDP-20 Series .....	13
NDP-P20 Series .....	15
NDP-25 Series .....	17
NDP-P25 Series.....	19
NDP-40 Series .....	21
NDP-50/500 Series.....	24
NDP-P50 Series.....	27
NDP-80 Series .....	29
NDP-32 Series .....	32
Specialty Models .....	33
Accessories.....	36
Pulsation Dampeners.....	39
Corrosion Resistant Chart/Installation Diagram	41
Market .....	42



# *Engineered to Perform. Designed for Long Life.*

## **Rugged, Bolted Construction**

All pumps feature bolted construction, which eliminates leak paths and simplifies assembly with actual torque values. This style is superior to clamp band retainer designs that bend or warp, thus causing misalignment and general assembly issues, possibly leading to more unnecessary repairs.

## **Outside-Accessible Air Valve**

Inspection or maintenance of every Yamada air valve may be performed without removing the pump from service.

## **Maintenance Indicator**

Reset button indicates when maintenance is due.

## **Unified Air Valve Concept**

Common-size air valve assemblies reduce parts confusion.

## **Pilot Valve**

Unique to the Yamada design is an individual modular pilot valve that actuates the air valve. It is depressed slightly by the inner center disk creating a pressure drop at one end of the air valve, allowing shifting to occur. It is maintenance free with no cumbersome snap rings or lubricated dynamic o-rings to replace or repair.

## **Optimal Stroke Length**

Extensive research has led to the development of an optimal stroke length that maximizes diaphragm life and performance while minimizing downtime and maintenance costs.



# Yamada Air Valve Technology

Yamada air valve technology is the heart of the air-powered double diaphragm pump and determines reliability. Yamada holds several patents on its field proven valve and enjoys a superior reputation throughout the industry.

## Unified Air Valve Concept

Yamada offers two common-size air valve assemblies (shown at right) fitting seven series of pumps, further reducing reassembly confusion and parts inventory. Other air-powered double diaphragm pump manufacturers offer multiple air valve designs and revisions in an effort to address ongoing pump reliability problems. Multiple designs and revisions typically create maintenance rebuild issues, parts confusion, and obsolete inventory. *Whether your pumps are functioning continuously or intermittently - at high or low pressure - using dirty or clean air - Yamada offers **one field proven design**.*

## Truly Non-Lubricated Air Valve

The patented Yamada air valve on all NDP series pumps never requires lubrication or pre-packing. The advanced design eliminates the need for external lubrication, which can lead to pumpage contamination and maintenance headaches.

***Yamada is proud to be the originator and still industry leader of non-lubricated air valve technology for air-powered double diaphragm pumps.***

Many other pump manufacturers claim to offer a non-lubricated air valve. These valves are pre-packed with grease and are not truly lube free. Depending upon the design, their air valves will require full time lubrication for continuous operation even requiring an inline lubricator be installed oftentimes, depending on the quality of the air running the pump.

## Component Replaceable

All Yamada air valves are designed with maintenance in mind and can be replaced quickly and efficiently without taking the pump out of service, reducing downtime.

Many competitor air valves can't be repaired and instead require complete replacement of the valve assembly and housing, further increasing the cost of ownership.

Simply remove four bolts and valve cap from the Yamada pump and slide the assembled air valve into the housing unit.

↓ Air Valve fits pump models  
NDP-20, NDP-25, NDP-32



Common-size Air Valve assemblies reduce parts confusion.

← air valve fits pump models NDP-40, NDP-50/500, NDP-80, and the Flap Valve Diaphragm pump.

## Non-Stalling

A patented non-centering, spring-assisted shifter is incorporated into every NDP Series pump, ensuring a positive shift every time.



The 304 stainless steel C-springs provide exceptional durability and longevity and are tested to last over **300 million cycles!**

The spring assist also aides in long dead head applications for reliable startup.

For additional information on Yamada products and services, visit [ap.yamadacorp.co.jp](http://ap.yamadacorp.co.jp)

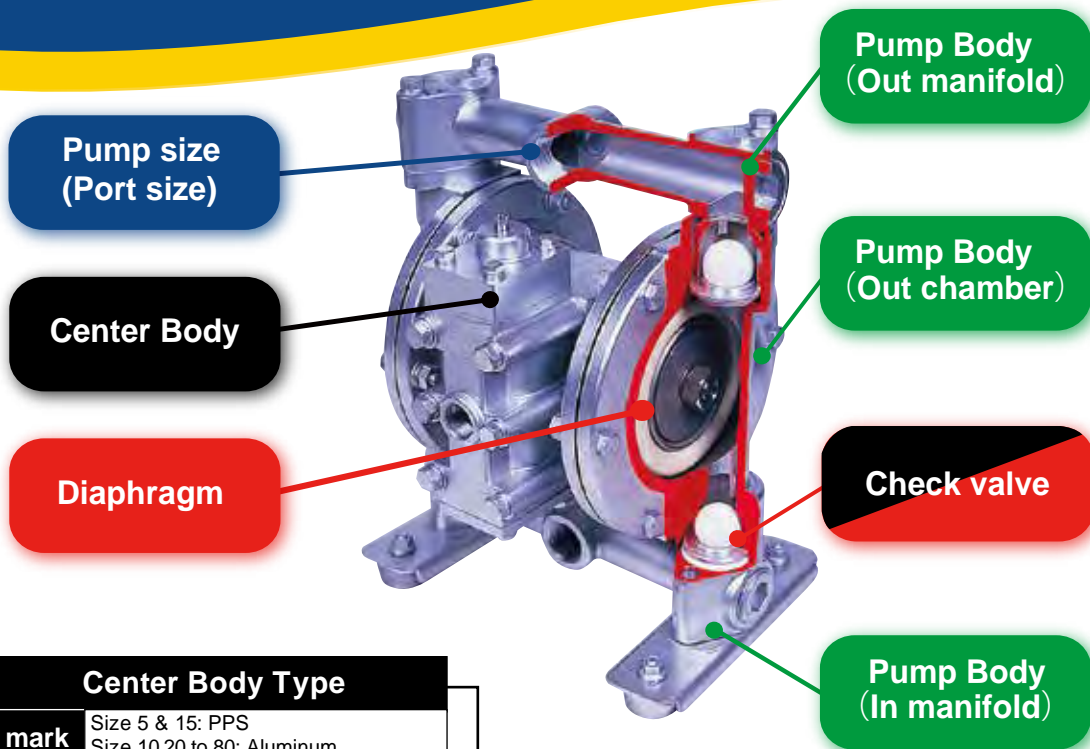
# Model Indicator

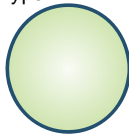

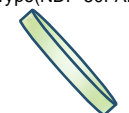
Check Valve	
B	Ball Type 
	Flat Type(PTFE for size 5&15) 
F	Flap Type(NDP-50FAN) 

Center Body Type	
No mark	Size 5 & 15: PPS Size 10,20 to 80: Aluminum
P	Polypropylene (Size 20 & 25 & 50)
H	Aluminum Mechanical Switch (Size 40, 50/500 & 80)

NDP-       

Pump Size	Port Type	Port Type	
		Rc thread / JIS flange	NPT thread / ANSI flange
5	Port size 1/4" (5mm)	Rc thread	NPT
10	Port size 3/8" (10mm)	Rc thread	NPT
15	Port size 1/2" (15mm)	Rc thread	NPT
20	Port size 3/4" (20mm)	Metal Body: Rc thread Plastic Body: JIS/DIN/ANSI flange, Rc thread	NPT
25	Port size 1" (25mm)	Metal Body: Rc thread Plastic Body: JIS/DIN flange, Rc thread	Metal Body: NPT Plastic Body: ANSI flange, NPT
32	Intake port size 1-1/2" (40mm), Discharge port size 1-1/4" (32mm)	Rc thread	NPT
40	Port size 1-1/2", (40mm)	JIS/DIN flange (Cast Iron Body: Rc thread)	ANSI flange (Cast Iron Body: NPT)
50/500	Port size 2", (50mm)	JIS/DIN/ANSI flange (Cast Iron Body: Rc thread)	ANSI flange (Cast Iron Body: NPT)
80	Port size 3", (80mm)	JIS/DIN/ANSI flange (Cast Iron Body: Rc thread)	ANSI flange (Cast Iron Body: NPT)

Pump Body Material	Liquid Temp Range	Characteristic
A Aluminum (ADC-12/AC4C-T6)	0 ~ 100°C	Good for oil and solvent. Not good for chemical, corrosive and abrasive
S Stainless Steel (SCS14/SUS316)	0 ~ 100°C	Hard and rust resistant. Good for corrosive and abrasive liquid
F Cast Iron (FC250/S45C)	0 ~ 100°C	Hard but easy to rust. Good for Iron oxide, sludge, etc.
P Polypropylene (PPG)	0 ~ 60°C	A tough flexible synthetic thermoplastic materials
V Kynar® (PVDF)	0 ~ 60°C	Good tensile and compressive strength and high impact strength
D Groundable Acetal (POM)	0 ~ 60°C	Excellent mechanical and high-temperature properties
T PTFE	0 ~ 100°C	A synthetic fluoropolymer of tetrafluoroethylene that is characteristically resistant to heat, acid oxidizing agents and to alkalis

Diaphragm/Check Valve Material	Liquid Temp Range	Characteristic
C Neoprene (CR)	0 ~ 70°C	A tough, synthetic rubber that is resistant to the effects of oils, solvents, heat, and weather
N Buna N (NBR)	0 ~ 70°C	An oil-resistant synthetic rubber that is resistant to oil, fuel, and other chemicals
E EPDM	0 ~ 80°C	A type of synthetic rubber that is resistant to heat, ozone and weather, polar substances and steam
H Hytrel® (TPEE)	0 ~ 100°C	A thermoplastic polyester elastomer that gives the flexibility of rubbers, the strength of plastics, and the processibility of thermoplastics
S Santoprene® (TPO)	0 ~ 100°C	A flexible and durable elastomer that has environmental aging resistance, electrical properties
V Viton® (FKM)	0 ~ 100°C	A fluoropolymer elastomer that has oil, heat and chemical resistance
T PTFE	0 ~ 100°C	A synthetic fluoropolymer of tetrafluoroethylene that that is characteristically resistant to heat, acid oxidizing agents and to alkalis
W PTFE+EPDM	0 ~ 90°C	Yamada offers a unique unified PTFE diaphragm with a bonded rubber backer and an outer disk integrated into the diaphragm.

# Fair Guideline of Pump size and Flow rate

Operation with the maximum cycle shorten the pump lifetime.

To optimize pump performance and lifetime, please select pump in reference to this guideline.

## Recommended Flow Rate by Pump Size

	L/min			
NDP-5	5		50	100
DP-10	10			
NDP-15		20		
NDP-20			60	
NDP-25			90	
NDP-40		200	250	500
NDP-50/500			320 (NDP-50)	380 (NDP-500)
NDP-80			450	

## Using Performance Curves

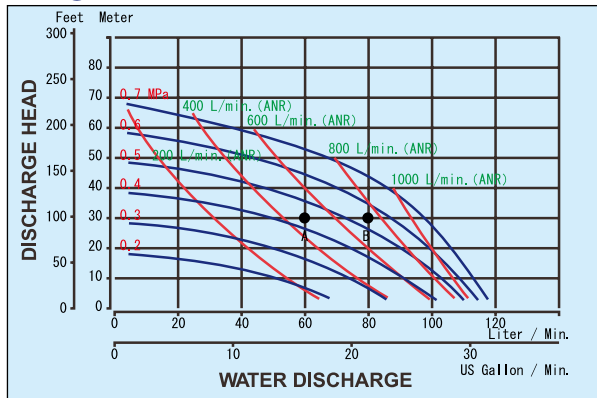

### Precautions for pump selection

\* Select a pump with safety margin (1.5 times or higher) appropriate for the required conditions with taking effective use of a diaphragm and other expendables into consideration.

\* The performance curve shown on the right indicates the data measured with fresh water (viscosity 1 mPa·s, specific gravity 1.0) by dip grazing with the shown devices. The amount of liquid discharged from the pump greatly varies depending on various factors such as the "viscosity, specific gravity and slurry concentration of liquid to be transferred," "suction lift," "discharge head" and "pneumatic transportation distance." If you are not sure which pump you should select, fill in the selection criterion of the "Inquiry Sheet" on the end of the document as much as possible, and contact us.

- The solid lines plot the relation between the amount of the discharged liquid ("water discharge") and the discharge head when the corresponding pressure is given. First, decide which curve corresponds to the desired air pressure.
- For example, when the supplied air pressure at your site is 0.5 MPa, check the curve marked "0.5 MPa."
- When liquid to be transferred is fresh water (viscosity is 1 mPa·s and specific gravity is 1.0), the desired water discharge is 60 L/min, and the discharge head is 30 m, the corresponding axes intersect at Point A. This point is located below the 0.5-Mpa curve and satisfies the desired water discharge and discharge head with this pump (Example: NDP-20).
- If it is required that "the water discharge is 80 L/min, and the discharge head is 30 m," the intersection point is "B" above the 0.5-MPa curve and this indicates that this pump cannot satisfy your conditions. In such a case, we recommend that you select the larger one (NDP-25).

## Specified Suction Lift

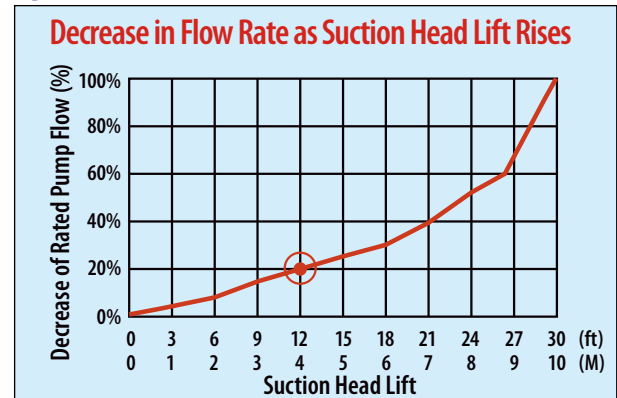

With a suction lift of 12-ft, 4m pump rate decreases by approximately 20%. Valid for pumps 3/4" and larger; data varies with pump configuration.

## Viscous Liquids Performance Data

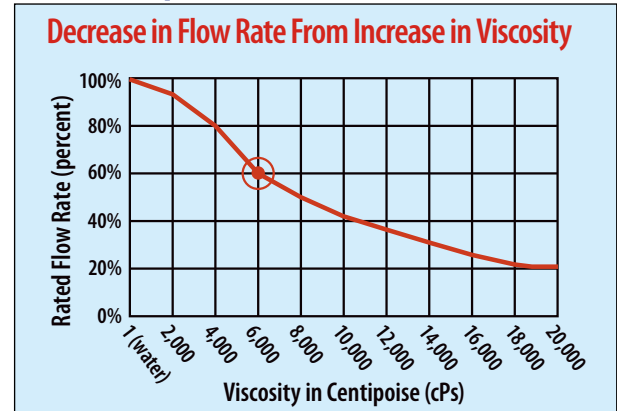

During the conveyance of a fluid with a viscosity of 6000 cPs, the pump rate decreases to 60% of its rated value (100% = water). Valid for 3/4" pumps & larger. Note: Please consult Yamada when both the pressure and temperature exceed 70 MPa and 180°C, respectively.

- The dashed lines plot curves for air consumption as shown in the graph respectively. The point A, intersection point as a result of the condition "3." above (water discharge: 60 L/min, discharge head: 30 m) is located about in the middle between the 400L/min air consumption curve and the 600L/min air consumption curve. Therefore, the air consumption under this condition is approximately 500 L/min (ANR). Since the air consumption is calculated by converting to the barometric pressure, it does not vary depending on the used air pressure.

# NDP-5 Series

11L/min Maximum Flow Rate  
1/4 inch Port Size

## Metal Body Pumps

## Plastic Body Pumps



NDP-5FST



NDP-5FPT



NDP-5FVT

## Specifications

Port Size		1/4" (6A)
Liquid	Intake	Rc1/4 or NPT1/4
	Discharge	
Air	Supply	Rc1/4 or NPT1/4 includes ball valve
	Exhaust	Rc3/8 or NPT3/8 w/ internal silencer*
Air Supply Pressure		0.2-0.7MPa
Maximum Discharge Pressure		0.7MPa
Discharge Volume Per Cycle		20mL
Maximum Size Solid		N/A
Net Weight		NDP-5FAT: 1.6kg NDP-5FST: 2.7kg NDP-5FPT: 1.3kg NDP-5FVT: 1.7kg
Body Material		Aluminum, Stainless Steel, Polypropylene, Kynar®
Diaphragm Material		PTFE

Liquid temperature-pressure correlation chart

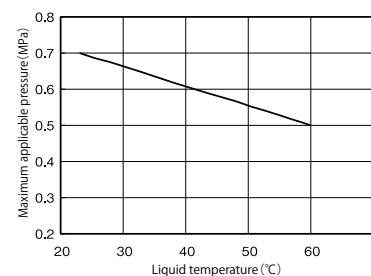

\*Silencer is internal type. Exhaust port has Rc3/8 or NPT3/8 thread.



# Dimensions and Performance Curve

NDP-5FAT, FST

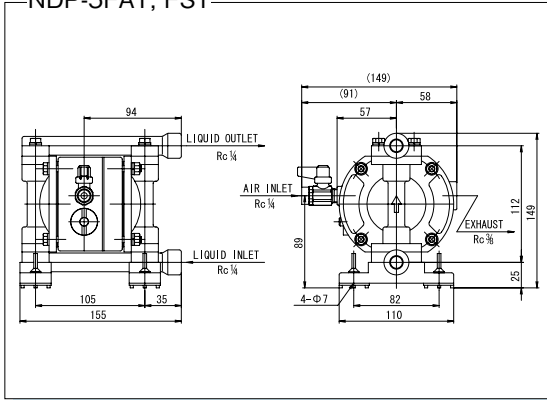

NDP-5FAT, FST

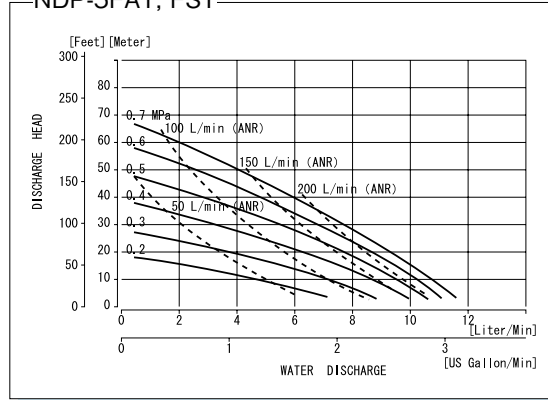

NDP-5FPT, FVT

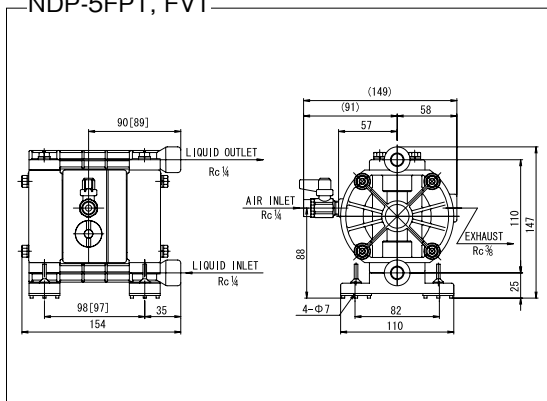

NDP-5FPT, FVT

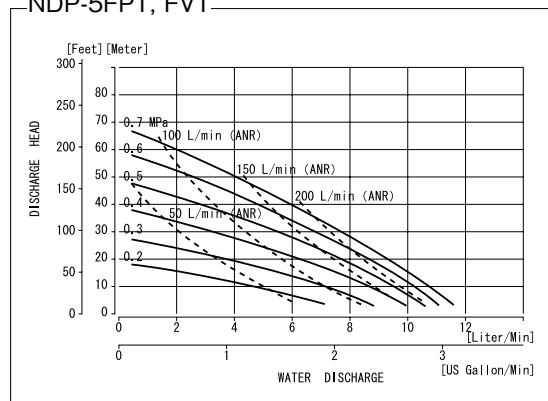

# DP-10 Series

20L/min Maximum Flow Rate  
3/8 inch Port Size

## Metal Body Pumps



## Plastic Body Pumps

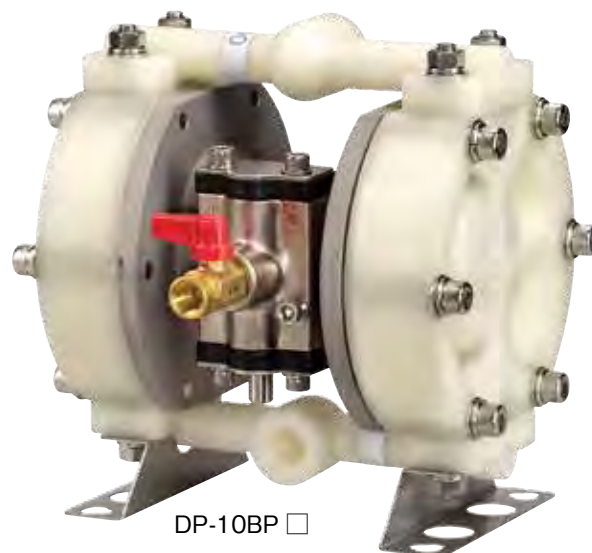

## Specifications

Port Size		3/8" (10A)
Liquid	Intake	Rc3/8 or NPT3/8
	Discharge	
Air	Supply	Rc1/4 or NPT1/4 includes ball valve
	Exhaust	Rc3/8 or NPT3/8 w/ silencer
Air Supply Pressure		0.2-0.7MPa
Maximum Discharge Pressure		0.7MPa
Discharge Volume Per Cycle		50mL
Maximum Size Solid		1mm
Net Weight		DP-10BA□: 3.5kg DP-10BS□: 5.2kg DP-10BP□: 3.0kg
Body Material		Aluminum, Stainless Steel, Polypropylene
Diaphragm Material		Neoprene, Buna N, PTFE, Hytel®, Santoprene®

Liquid temperature-pressure correlation chart

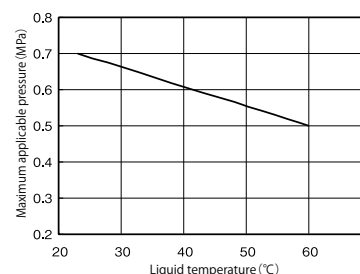

# Dimensions and Performance Curve

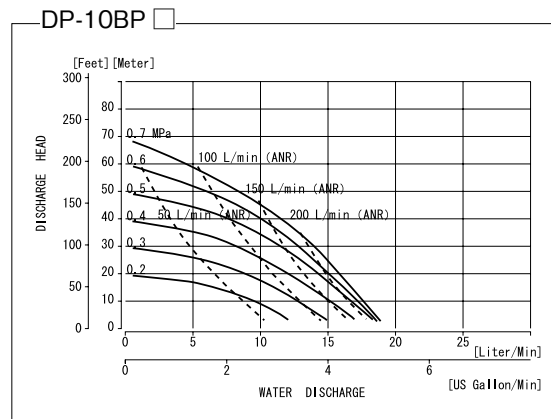
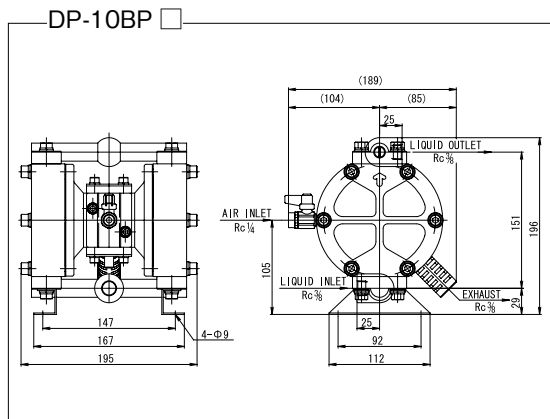
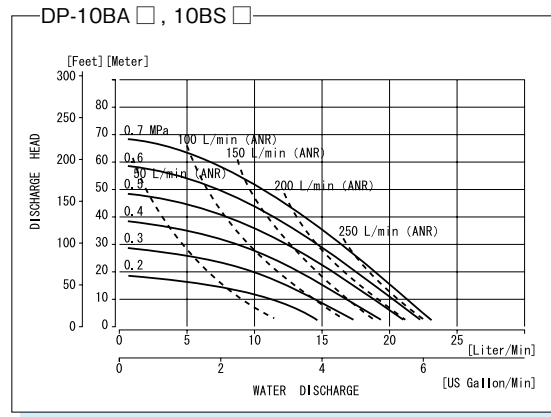
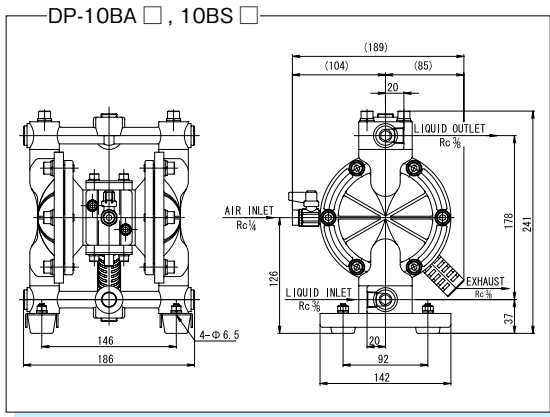

# NDP-15 Series

50L/min Maximum Flow Rate  
1/2 inch Port Size

## Metal Body Pumps



NDP-15BA □



NDP-15BS □

## Plastic Body Pumps



NDP-15FP □ ,BP □



NDP-15FVT

## Specifications

Port Size		1/2" (15A)
Liquid	Intake	Rc1/2 or NPT1/2
	Discharge	
Air	Supply	Rc1/4 or NPT1/4 includes ball valve
	Exhaust	Rc3/8 or NPT3/8 w/ internal silencer*
Air Supply Pressure		0.2-0.7MPa
Maximum Discharge Pressure		0.7MPa
Discharge Volume Per Cycle		70mL
Maximum Size Solid		1mm
Net Weight		NDP-15BA□ : 4.1kg NDP-15BS□ : 6.3kg NDP-15FP□ : 3.5kg NDP-15FVT : 4.3kg
Body Material		Aluminum, Stainless Steel, Polypropylene, Kynar®
Diaphragm Material		Neoprene, Buna N, PTFE, Hytrel®, Santoprene®

Liquid temperature-pressure correlation chart

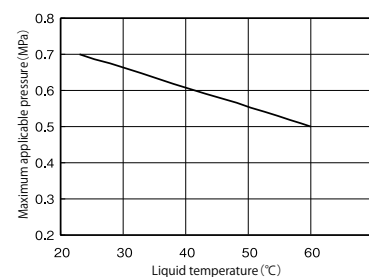

\*Silencer is internal type. Exhaust port has Rc3/8 or NPT3/8 thread.

# Dimensions and Performance Curve

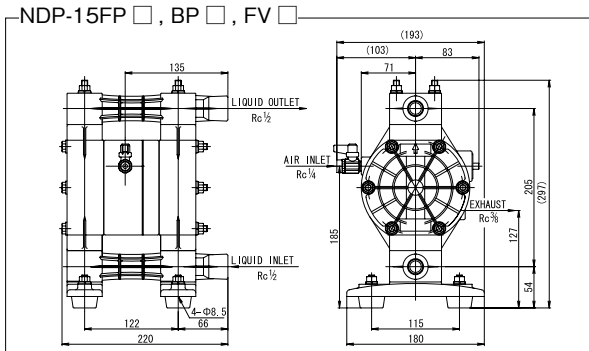
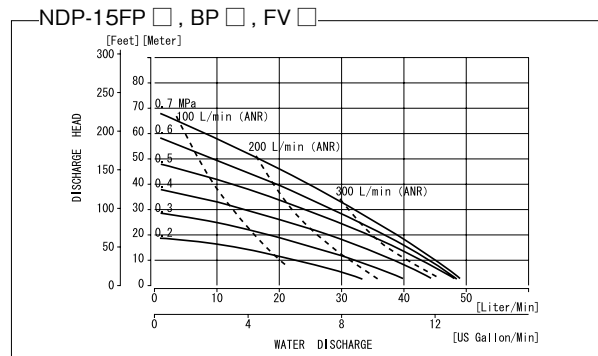
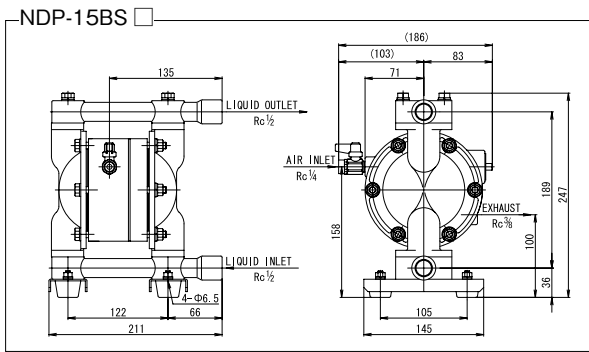
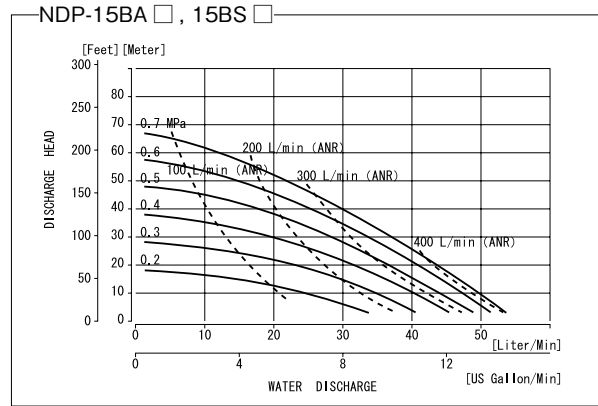
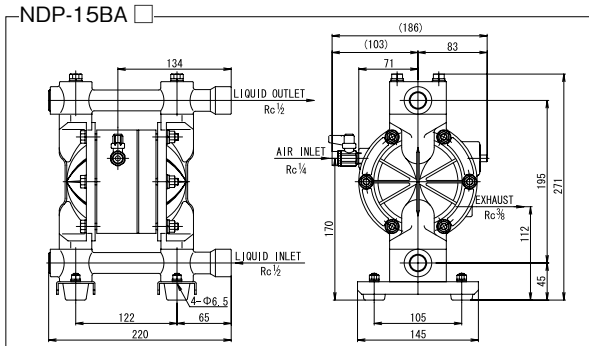

# NDP-20 Series

110L/min Maximum Flow Rate  
3/4 inch Port Size

## Metal Body Pumps



NDP-20BA □

## Plastic Body Pumps

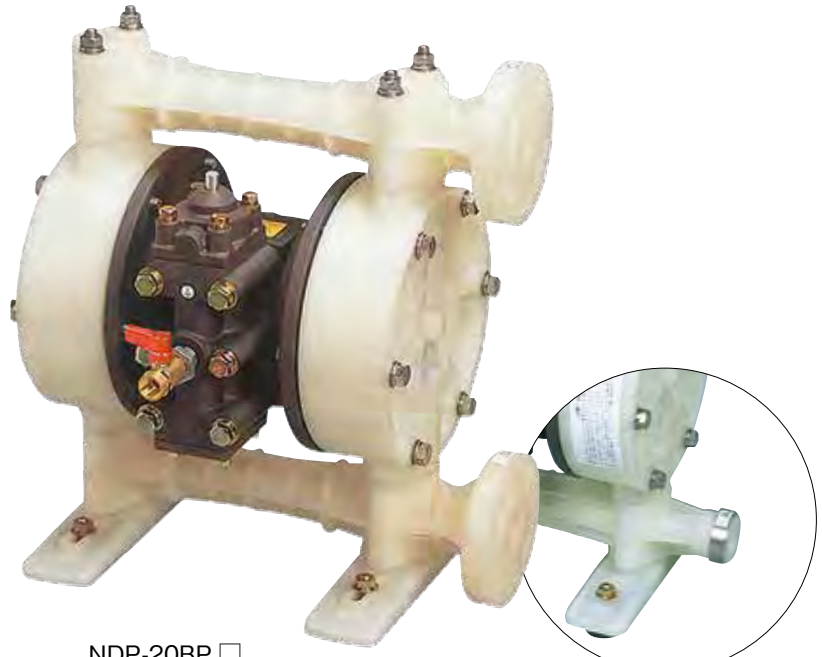

NDP-20BP □  
(Flange type)

(RC type)

## Specifications

Port Size		3/4" (20A)
Liquid	Intake	Metal Body: Rc3/4 or NPT3/4
	Discharge	Plastic Body: JIS/DIN/ANSI Compatible Flange, Rc3/4 or NPT3/4
Air	Supply	Rc1/4 or NPT1/4 includes ball valve
	Exhaust	Rc3/4 or NPT3/4 w/ silencer
Air Supply Pressure		0.2-0.7MPa
Maximum Discharge Pressure		0.7MPa
Discharge Volume Per Cycle		Rubber diaphragm: 350mL PTFE diaphragm: 240mL
Maximum Size Solid		2mm
Net Weight		NDP-20BA□: 9.0kg NDP-20BS□: 14.0kg NDP-20BP□: 8.0kg
Body Material		Aluminum, Stainless Steel, Polypropylene
Diaphragm Material		Neoprene, Buna N, EPDM, Viton®, PTFE, Hytrel®, Santoprene®

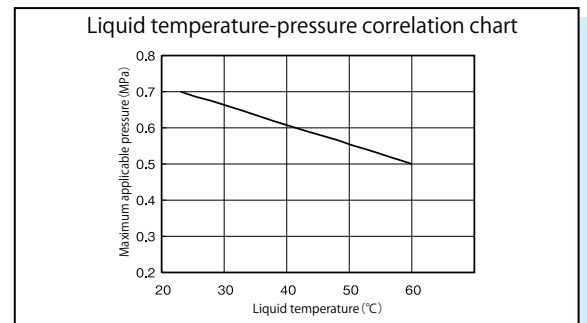

# Dimensions and Performance Curve

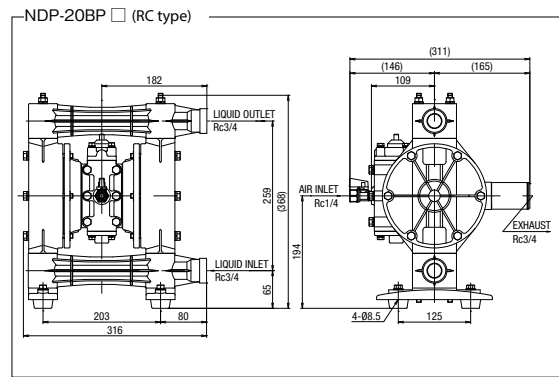
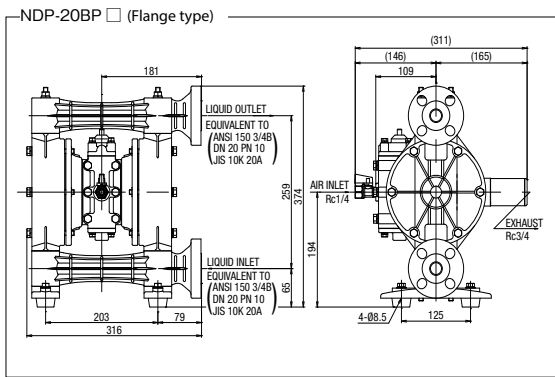
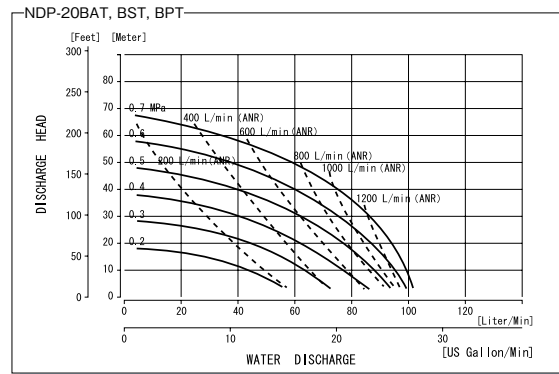
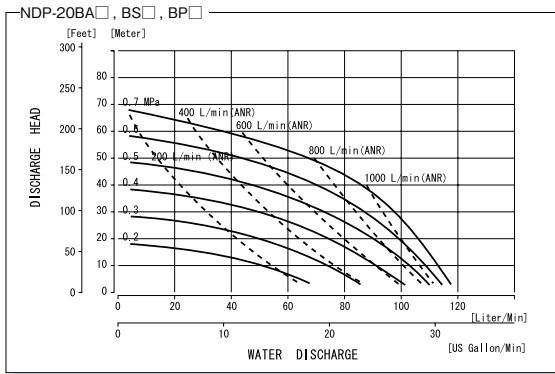
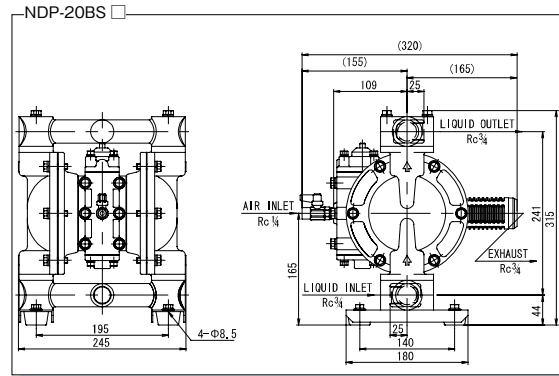
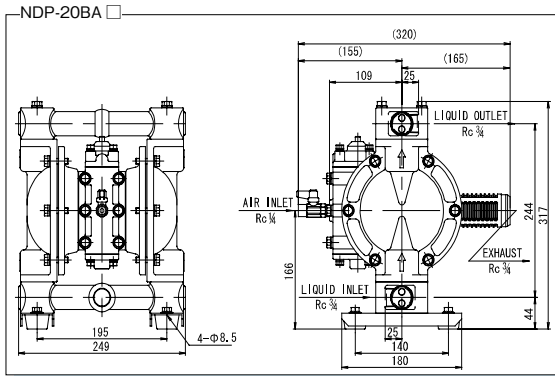

# NDP-P20 Series

110L/min Maximum Flow Rate  
3/4 inch Port Size

## Metal Body Pumps



NDP-P20BA □

## Plastic Body Pumps

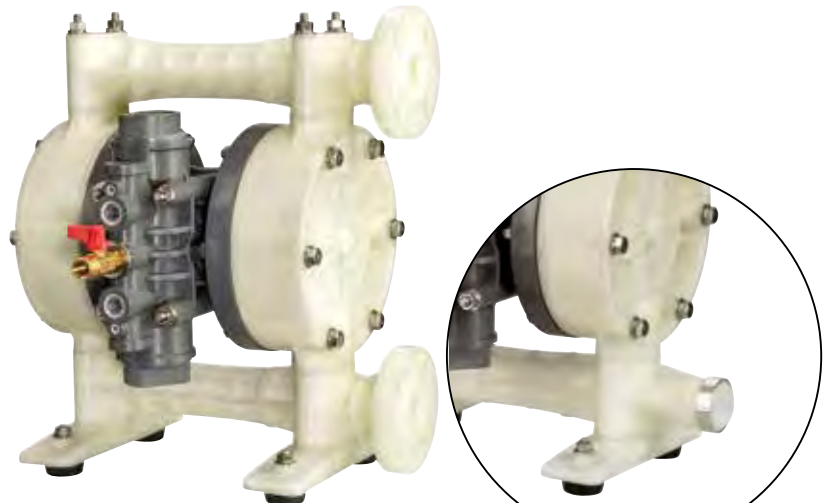

NDP-P20BP □ -FL  
(Flange type)

(Rc type)



NDP-P20BTT

## Specifications

Port Size		3/4" (20A)
Liquid	Intake	Metal Body: Rc3/4 or NPT3/4
	Discharge	Plastic Body: JIS/DIN/ANSI Compatible Flange, Rc3/4 or NPT3/4
Air	Supply	BTT: JIS Flange
	Exhaust	Rc1/4 or NPT1/4 includes ball valve Rc3/4 or NPT3/4 w/ silencer
Air Supply Pressure		0.2-0.7MPa (0.2-0.5MPa for P20BTT)
Maximum Discharge Pressure		0.7MPa (0.5MPa for P20BTT)
Discharge Volume Per Cycle		Rubber diaphragm: 350mL PTFE diaphragm: 240mL (290ml for P20BTT)
Maximum Size Solid		2mm
Net Weight		NDP-P20BA□: 7.5kg NDP-P20BS□: 12.5kg NDP-P20BP□: 7.0kg NDP-P20BTT: 20.0kg
Body Material		Aluminum, Stainless Steel, Polypropylene, PTFE
Diaphragm Material		Neoprene, Buna N, EPDM, Viton®, PTFE, Hytrel®, Santoprene®

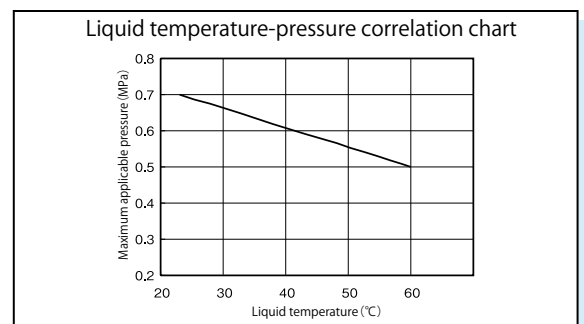



# Dimensions and Performance Curve

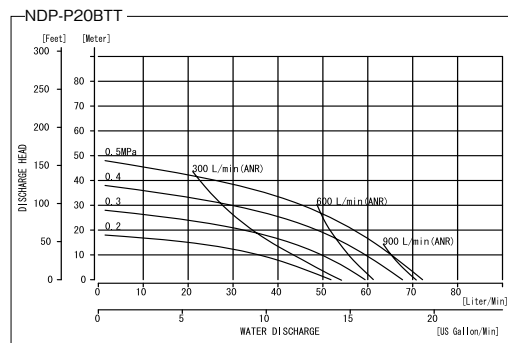
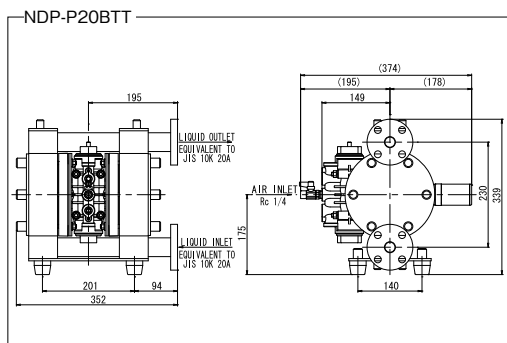
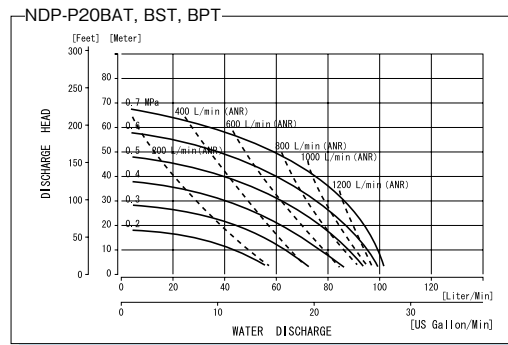
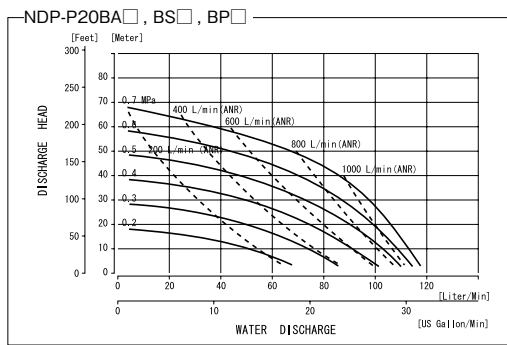
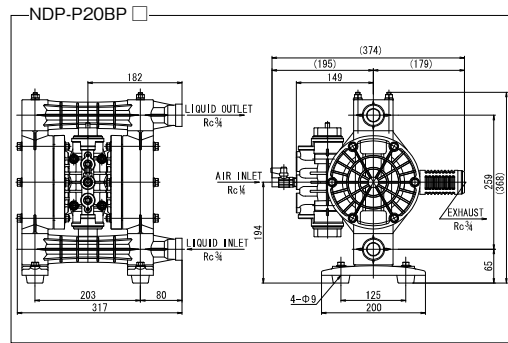
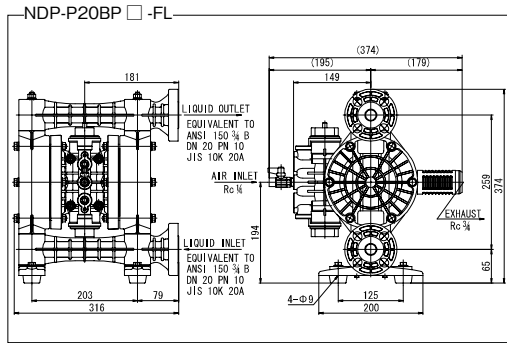
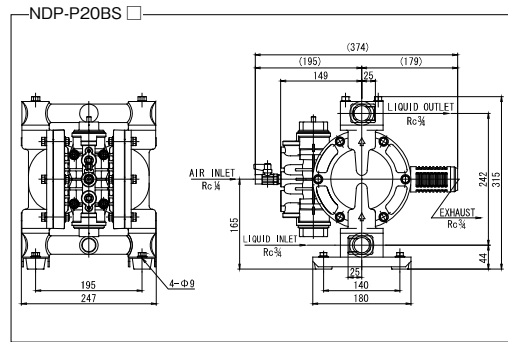
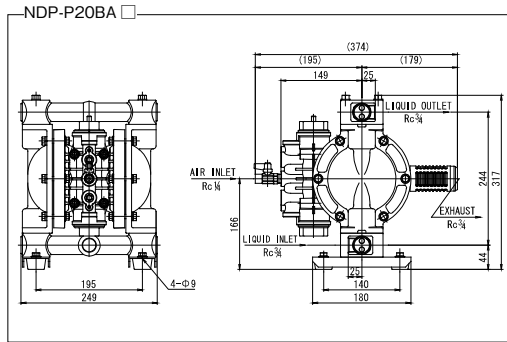

# NDP-25 Series

160L/min Maximum Flow Rate  
1 inch Port Size

## Metal Body Pumps



NDP-25BA □

## Plastic Body Pumps



NDP-25BP □ -FL  
(Flange type)



(Rc type)



NDP-25BV □ -FL  
(Flange type)



(Rc type)

## Specifications

Port Size	1" (25A)	
Liquid	Intake	Metal Body: Rc1 or NPT1
	Discharge	Plastic Body: JIS/DIN Compatible Flange, ANSI Flange, Rc1 or NPT1
Air	Supply	Rc3/8 or NPT3/8 includes ball valve
	Exhaust	Rc3/4 or NPT3/4 w/ silencer
Air Supply Pressure	0.2-0.7MPa	
Maximum Discharge Pressure	0.7MPa	
Discharge Volume Per Cycle	Rubber diaphragm: 600mL PTFE diaphragm: 500mL	
Maximum Size Solid	3mm	
Net Weight	NDP-25BA□: 13.0kg NDP-25BS□: 20.0kg NDP-25BF□: 20.0kg NDP-25BP□: 11.0kg NDP-25BV□: 13.5kg	
Body Material	Aluminum, Stainless Steel, Cast Iron, Polypropylene, Kynar®	
Diaphragm Material	Neoprene, Buna N, EPDM, Viton®, PTFE, Hytrel®, Santoprene®	

Liquid temperature-pressure correlation chart

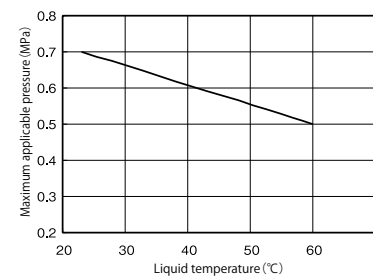

# Dimensions and Performance Curve

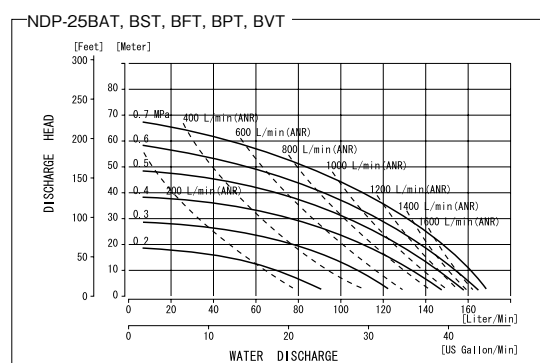
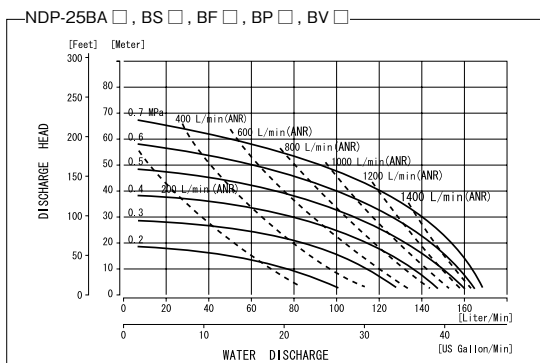
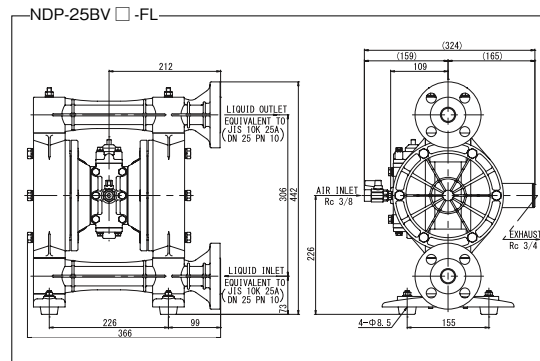
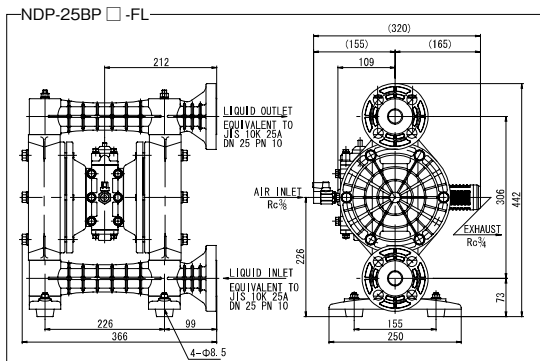
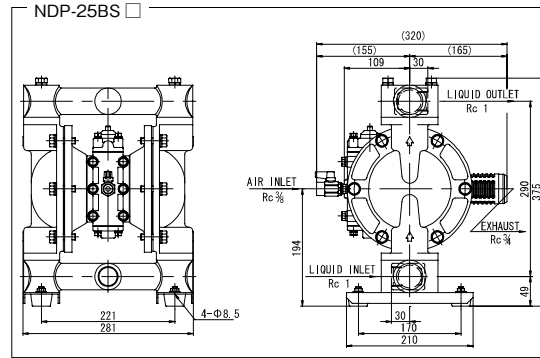
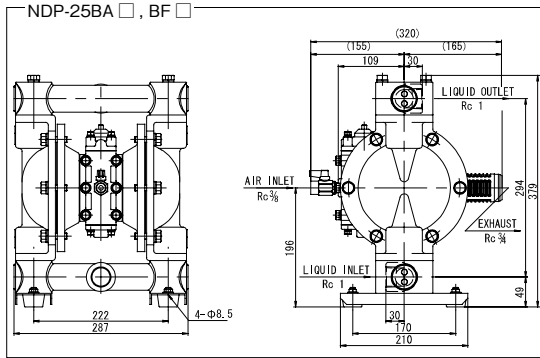

# NDP-P25 Series

160L/min Maximum Flow Rate  
1 inch Port Size

## Metal Body Pumps



NDP-P25BA □, BS □

## Plastic Body Pumps



NDP-P25BP □ -FL



NDP-P25BV □ -FL

## Specifications

Port Size		1" (25A)
Liquid	Intake	Metal Body: Rc1 or NPT1 Plastic Body: JIS/DIN Compatible Flange, ANSI Flange, Rc1 or NPT1
	Discharge	BTT: JIS Flange
Air	Supply	Rc3/8 or NPT3/8 includes ball valve
	Exhaust	Rc3/4 or NPT3/4 w/ silencer
Air Supply Pressure		0.2-0.7MPa (0.2-0.5MPa for P25BTT)
Maximum Discharge Pressure		0.7MPa (0.5MPa for P25BTT)
Discharge Volume Per Cycle		Rubber diaphragm: 600mL PTFE diaphragm: 500mL
Maximum Size Solid		3mm
Net Weight		NDP-P25BA□: 11.0kg NDP-P25BS□: 18.0kg NDP-P25BP□: 9.5kg NDP-P25BV□: 12.0kg NDP-P25BTT: 33.0kg
Body Material		Aluminum, Stainless Steel, Polypropylene, Kynar®, PTFE
Diaphragm Material		Neoprene, Buna N, EPDM, Viton®, PTFE, Hytrel®, Santoprene®

Liquid temperature-pressure correlation chart

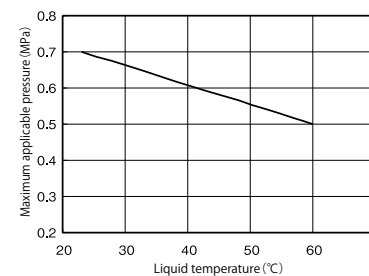

# Dimensions and Performance Curve

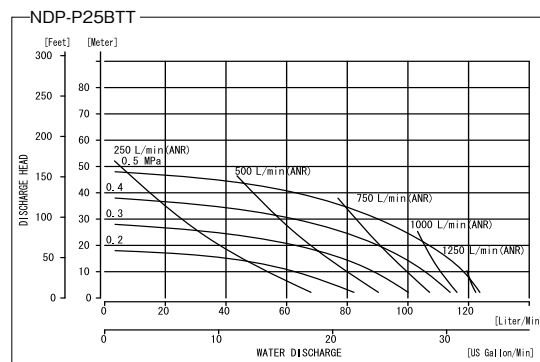
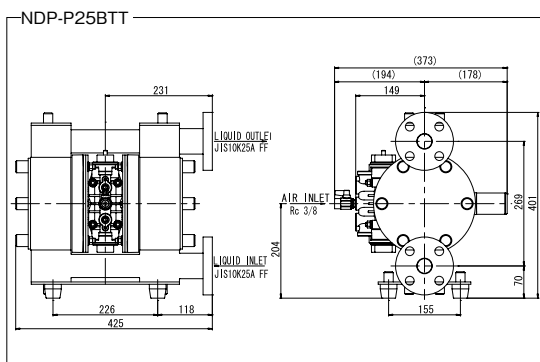
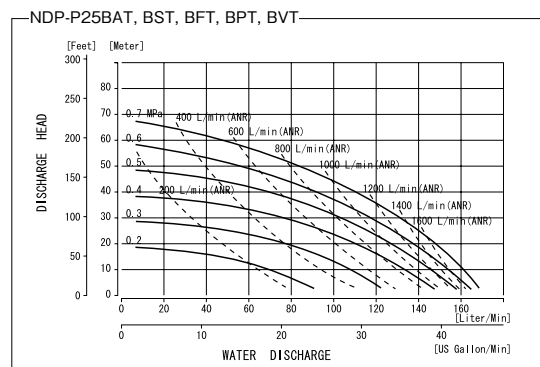
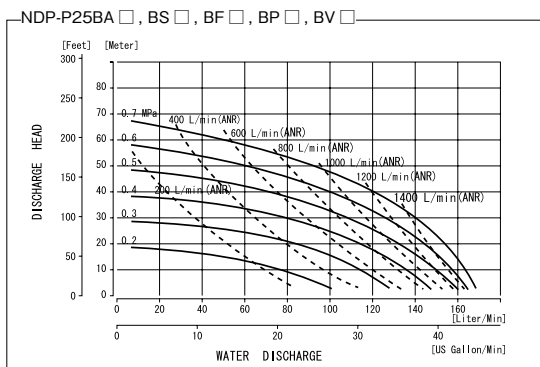
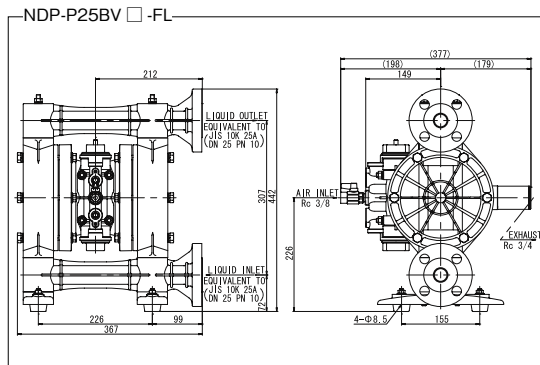
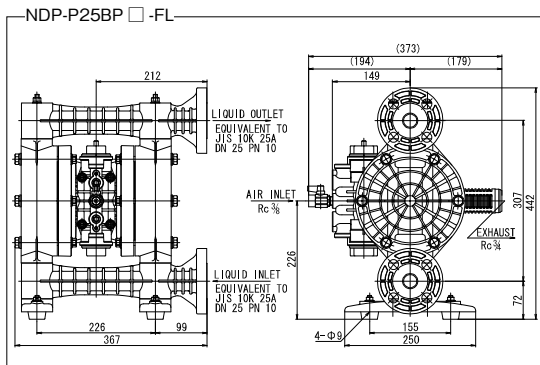
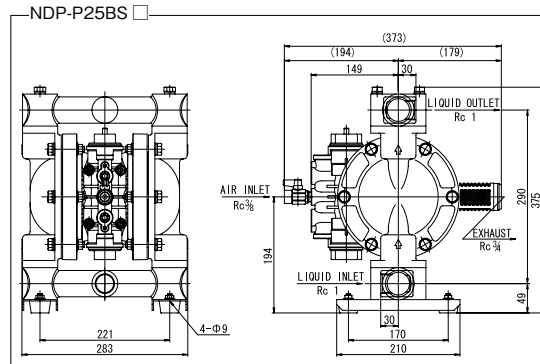
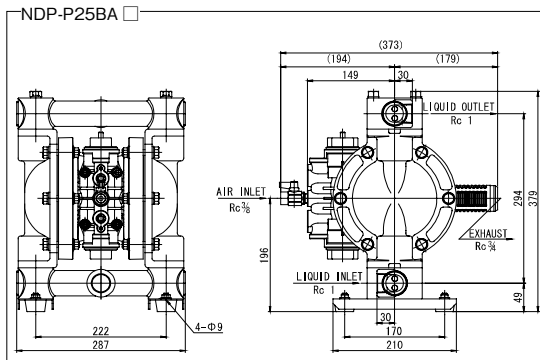

# NDP-40 Series

350L/min Maximum Flow Rate  
1-1/2 inch Port Size

## Metal Body Pumps



NDP-40BS □



NDP-40BF □

## Plastic Body Pumps



NDP-40BP □



NDP-40BV □

## Specifications

Port Size		1-1/2" (40A)
Liquid	Intake	BA □ : JIS/DIN Compatible Flange or ANSI Flange w/ NPTF BS □ : JIS/DIN Compatible Flange or ANSI Flange
	Discharge	BF □ : Rc1-1/2 or NPTF1-1/2 BP □ : JIS/DIN Compatible Flange or ANSI Flange BV □ : JIS/DIN Compatible Flange or ANSI Flange
Air	Supply	Rc1/2 or NPT1/2 includes ball valve
	Exhaust	Rc1 or NPT1 w/ silencer
Air Supply Pressure		0.2-0.7MPa
Maximum Discharge Pressure		0.7MPa
Discharge Volume Per Cycle		Rubber diaphragm: 2.4L (2.5L for 40BP □ and 40BV □) PTFE diaphragm: 1.4L (1.3L for 40BPT and 40BVT) PTFE+EPDM diaphragm: 1.4L
Maximum Size Solid		7mm
Net Weight		NDP-40BA □: 27.0kg NDP-40BAT: 26.5kg NDP-40BAW: 26.5kg NDP-40BS □: 42.8kg NDP-40BST: 41.5kg NDP-40BSW: 41.5kg NDP-40BF □: 47.2kg NDP-40BFT: 46.0kg NDP-40BFW: 46.0kg NDP-40BP □: 27.2kg NDP-40BPW: 26.2kg NDP-40BV □: 32.2kg NDP-40BVW: 31.2kg
Body Material		Aluminum, Stainless Steel, Cast Iron, Polypropylene, Kynar®
Diaphragm Material		Neoprene, Buna N, EPDM, Viton®, PTFE, Hytrel®, Santoprene®, PTFE+EPDM

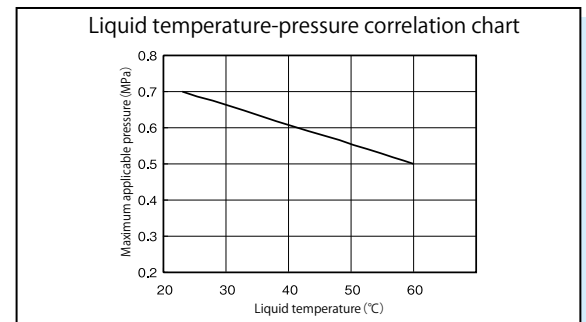

# Dimensions and Performance Curve

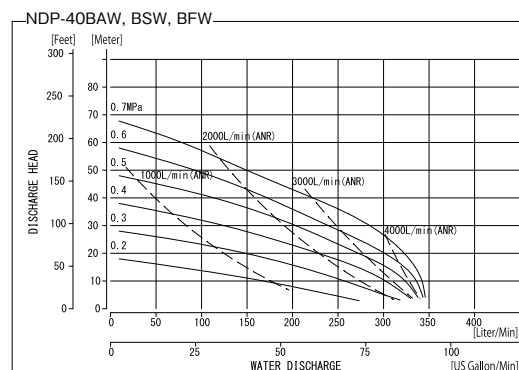
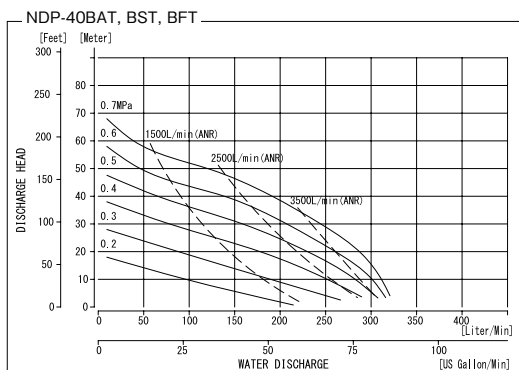
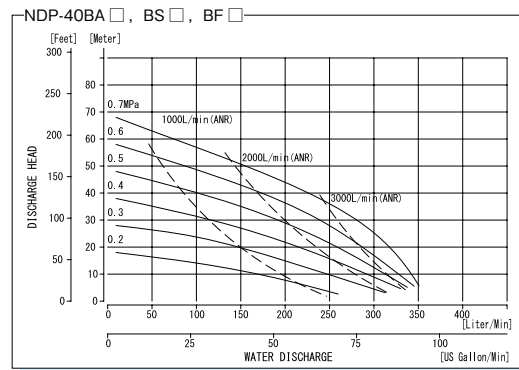
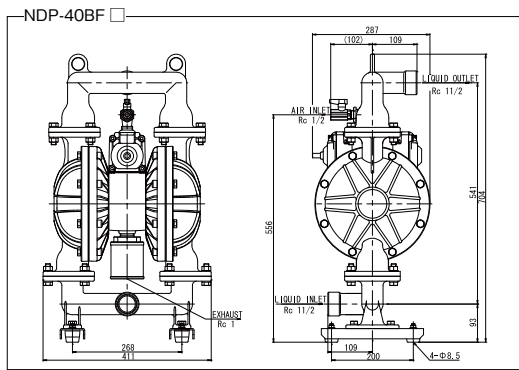
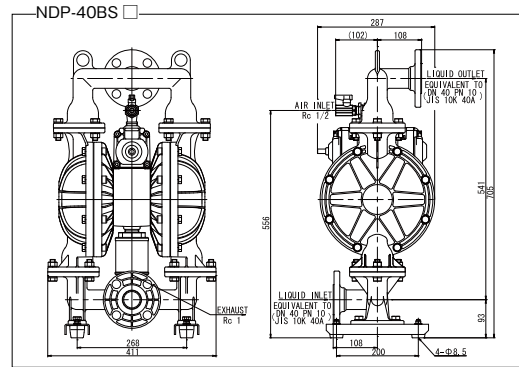
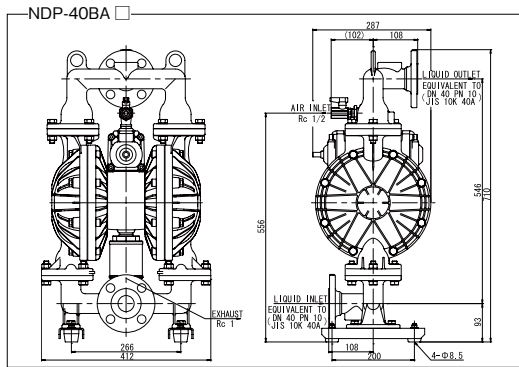

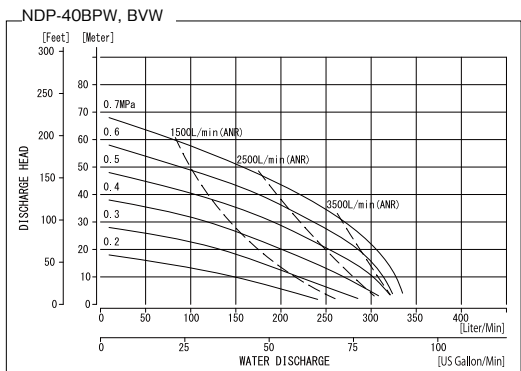
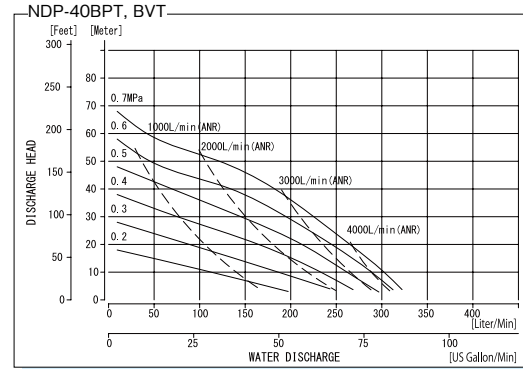
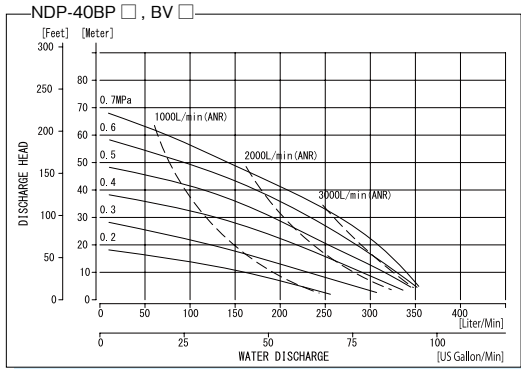
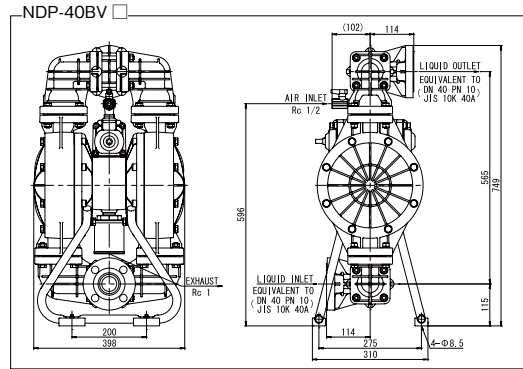
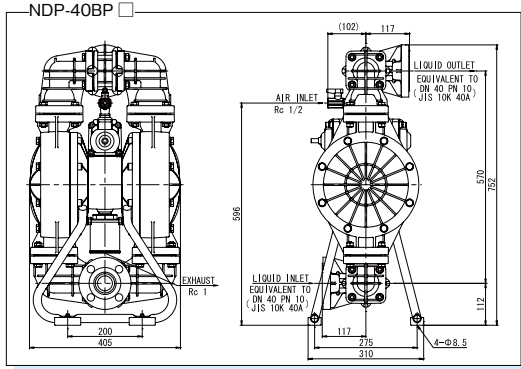



# NDP-50/500 Series 780L/min Maximum Flow Rate 2 inch Port Size

## Metal Body Pumps

## Plastic Body Pumps



NDP-500BS □



NDP-50BA □



NDP-50BP □



NDP-50BV □

## Specifications

Port Size		2" (50A)
Liquid	Intake	BA □ : JIS/DIN Compatible Flange or ANSI Flange w/ NPTF BS □ : JIS/DIN/ANSI Compatible Flange or ANSI Flange BF □ : Rc2 or NPTF2
	Discharge	BP □ : JIS/DIN/ANSI Compatible Flange or ANSI Flange BV □ : JIS/DIN Compatible Flange or ANSI Flange
Air	Supply	Rc3/4 or NPT3/4 includes ball valve
	Exhaust	Rc1 or NPT1 w/ silencer
Air Supply Pressure		0.2-0.7MPa
Maximum Discharge Pressure		0.7MPa
Discharge Volume Per Cycle		Rubber diaphragm: 4.3L PTFE diaphragm: 2.5L (2.4L for 500BST/ 2.1L for 50BPT and 50BVT) PTFE+EPDM diaphragm: 1.8L (2.0L for 500BSW, 50BPW, and 50BVW)
Maximum Size Solid		8mm
Net Weight		NDP-50BA □: 34.5kg NDP-50BAT: 32.5kg NDP-50BAW: 33.5kg NDP-50BS □: 62.0kg NDP-50BST: 58.5kg NDP-50BSW: 59.5kg NDP-50BF □: 65.0kg NDP-50BFT: 61.5kg NDP-50BFW: 62.5kg NDP-50BP □: 35.0kg NDP-50BV □: 41.0kg NDP-500BS □: 60.0kg NDP-500BST: 57.8kg NDP-500BSW: 57.4kg
Body Material		Aluminum, Stainless Steel, Cast Iron, Polypropylene, Kynar®
Diaphragm Material		Neoprene, Buna N, EPDM, Viton®, PTFE, Hytrel®, Santoprene®, PTFE+EPDM

Liquid temperature-pressure correlation chart

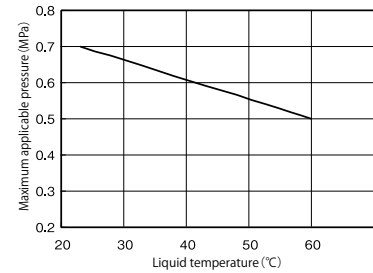

# Dimensions and Performance Curve

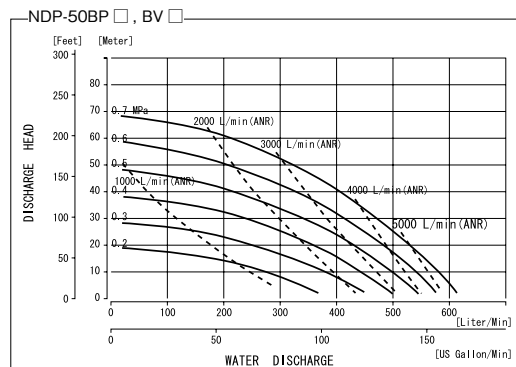
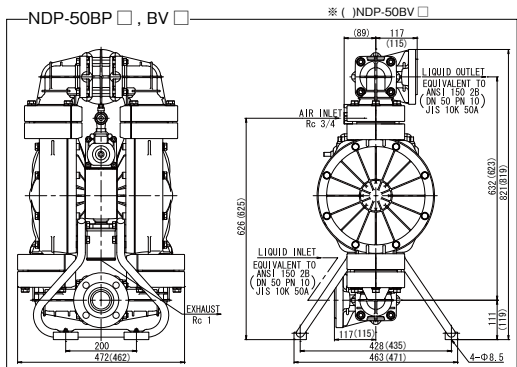
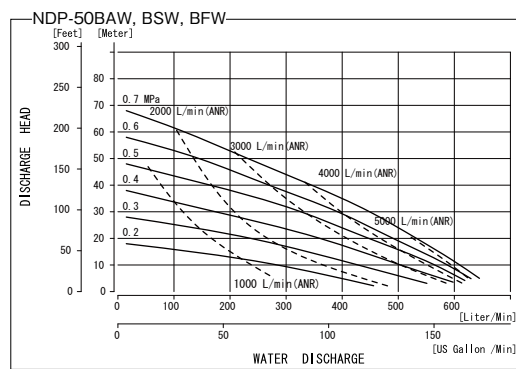
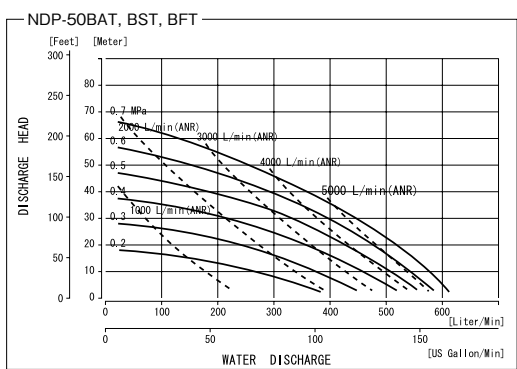
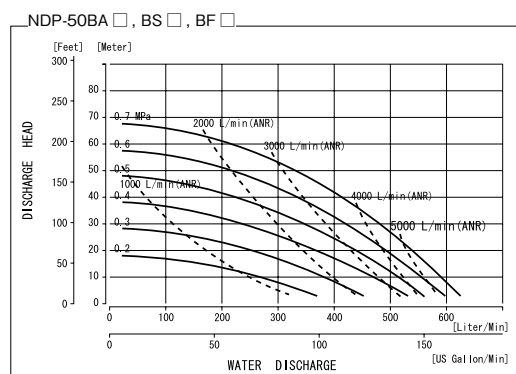
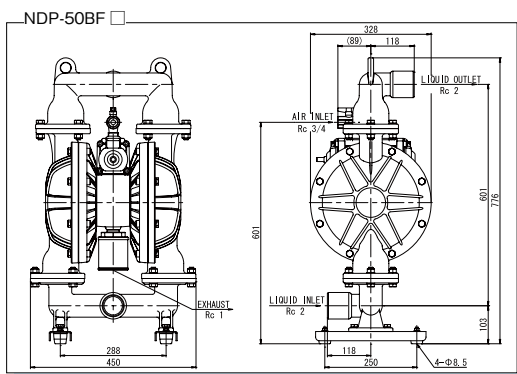
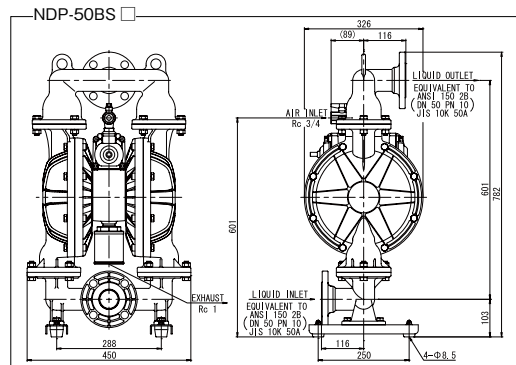
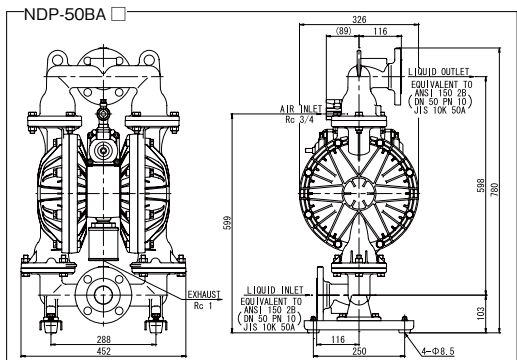

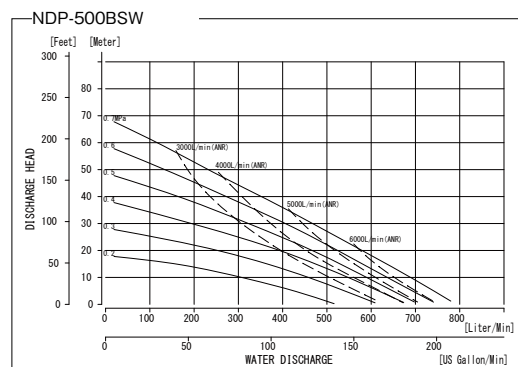
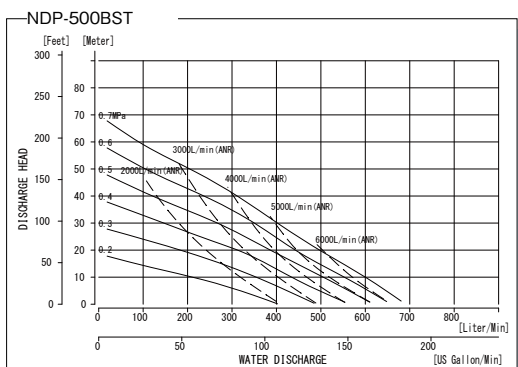
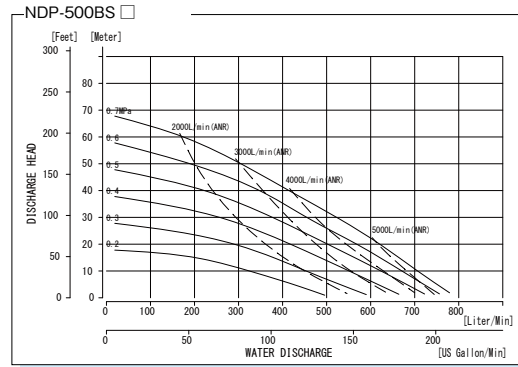
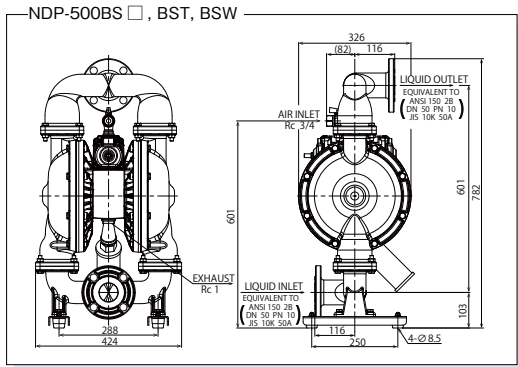
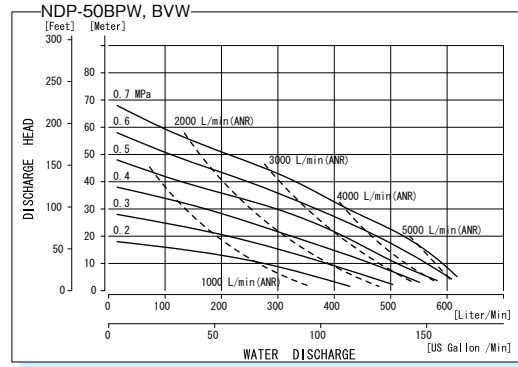
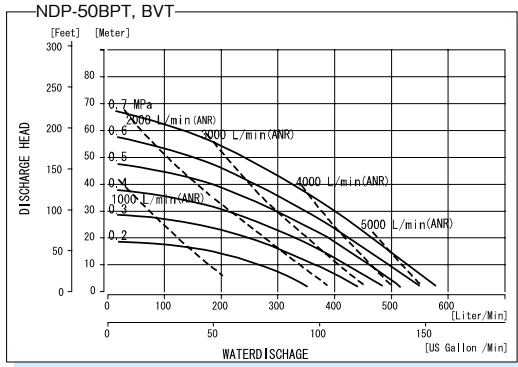

# NDP-P50 Series

600L/min Maximum Flow Rate  
2 inch Port Size

## Plastic Body Pumps



NDP-P50BP □



NDP-P50BV □

## Specifications

Port Size		2" (50A)
Liquid	Intake	BP□ : JIS/DIN/ANSI Compatible Flange or ANSI Flange
	Discharge	BV□ : JIS/DIN Compatible Flange or ANSI Flange
Air	Supply	Rc3/4 or NPT3/4 includes ball valve
	Exhaust	Rc1 or NPT1 w/ silencer
Air Supply Pressure		0.2-0.7MPa
Maximum Discharge Pressure		0.7MPa
Discharge Volume Per Cycle		Rubber diaphragm: 4.1L PTFE diaphragm: 2.3L PTFE+EPDM diaphragm: 1.6L
Maximum Size Solid		8mm
Net Weight		NDP-P50BP□: 37.0kg NDP-P50BPW: 34.0kg NDP-P50BV□: 43.0kg NDP-P50BVW: 40.0kg
Body Material		Polypropylene, Kynar®
Diaphragm Material		Neoprene, Buna N, EPDM, Viton®, PTFE, Hytrel®, Santoprene®, PTFE+EPDM

Liquid temperature-pressure correlation chart

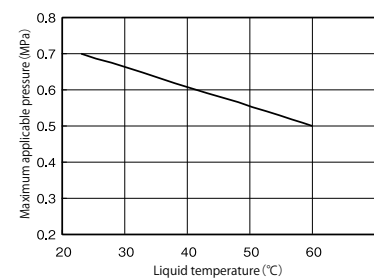

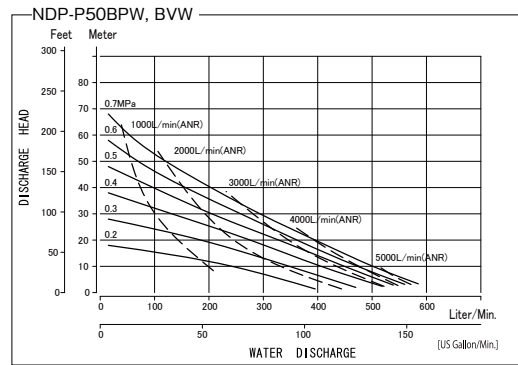
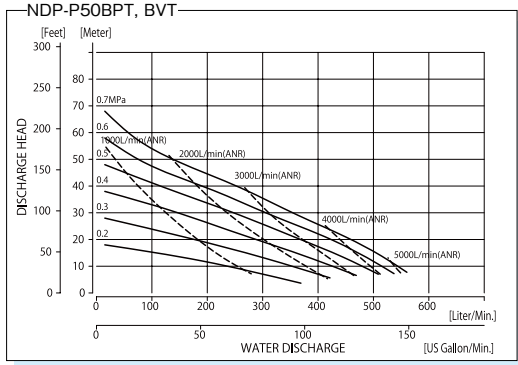
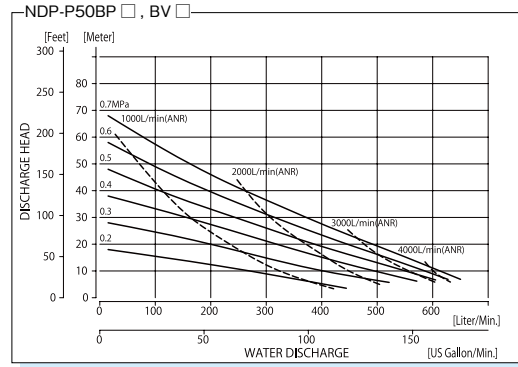
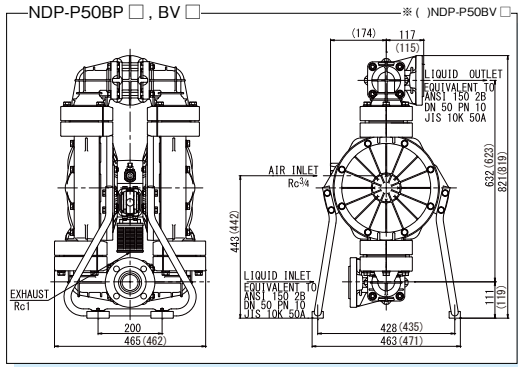

# NDP-80 Series

800L/min Maximum Flow Rate  
3 inch Port Size

## Metal Body Pumps



NDP-80BA □



NDP-80BP □

## Specifications

Port Size		3" (80A)
Liquid	Intake	BA □ : JIS/DIN/ANSI Compatible Flange or ANSI Flange w/ NPTF
	Discharge	BS □ : JIS/DIN/ANSI Compatible Flange or ANSI Flange BF □ : Rc3 or NPT3 BP □ : JIS/DIN/ANSI Compatible Flange or ANSI Flange
Air	Supply	Rc3/4 or NPT3/4 includes ball valve
	Exhaust	Rc1 or NPT1 w/ silencer
Air Supply Pressure		0.2-0.7MPa
Maximum Discharge Pressure		0.7MPa
Discharge Volume Per Cycle		Rubber diaphragm: 8.7L (8.5L for 80BP □) PTFE diaphragm: 3.5L (3.8L for 80BPT) PTFE+EPDM diaphragm: 5.4L (5.0L for 80BPW)
Maximum Size Solid		10mm
Net Weight		NDP-80BA □: 62.0kg NDP-80BAT: 58.5kg NDP-80BAW: 61.0kg NDP-80BS □: 109.0kg NDP-80BST: 101.5kg NDP-80BSW: 104.0kg NDP-80BF □: 109.5kg NDP-80BFT: 101.5kg NDP-80BFW: 104.0kg NDP-80BP □: 65.5kg NDP-80BPT: 61.5kg NDP-80BPW: 67.5kg
Body Material		Aluminum, Stainless Steel, Cast Iron, Polypropylene
Diaphragm Material		Neoprene, Buna N, EPDM, Viton®, PTFE, Hytrel®, Santoprene®, PTFE+EPDM

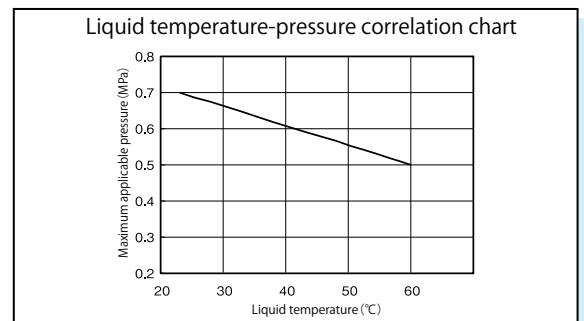

# Dimensions and Performance Curve

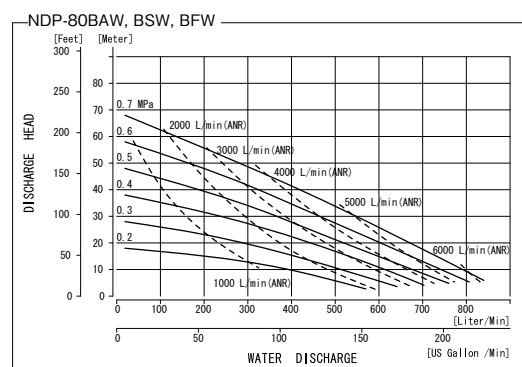
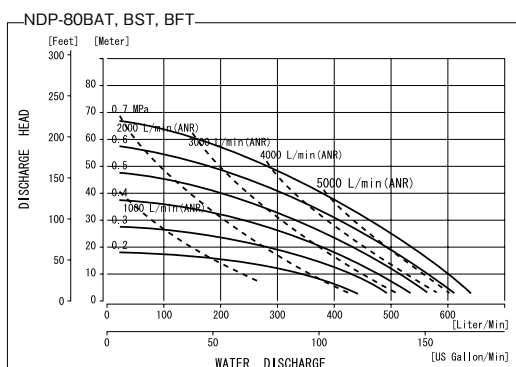
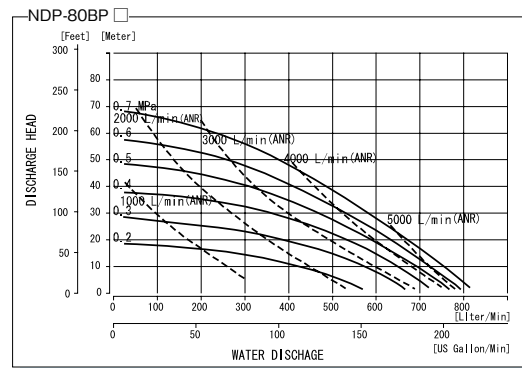
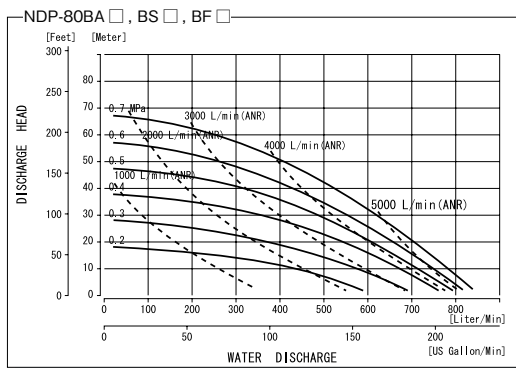
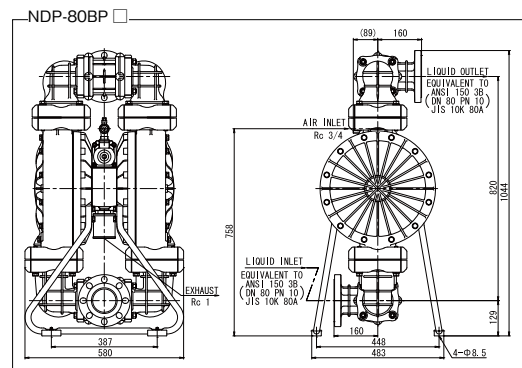
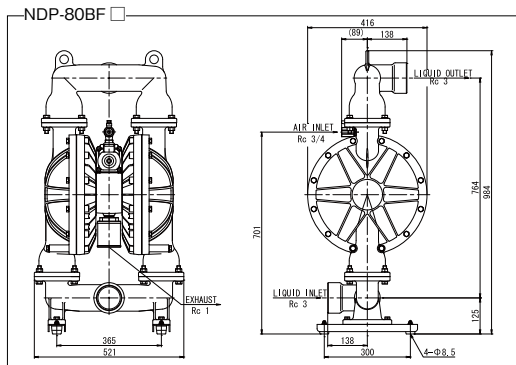
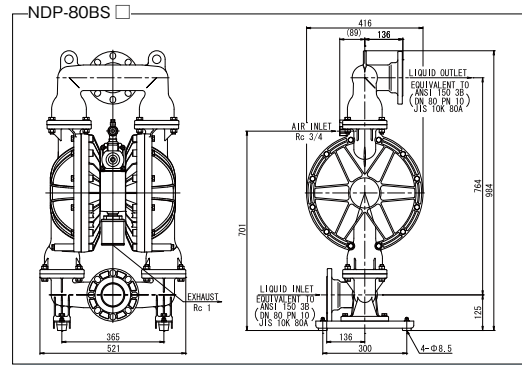
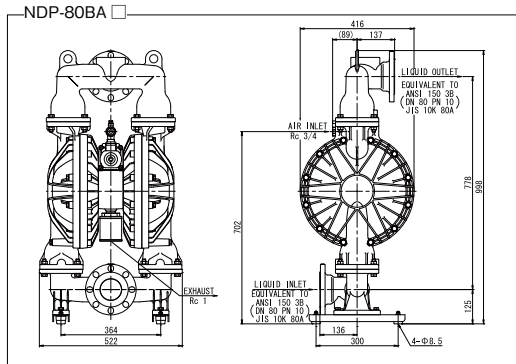

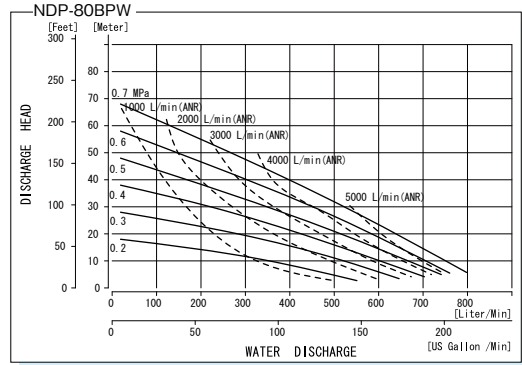
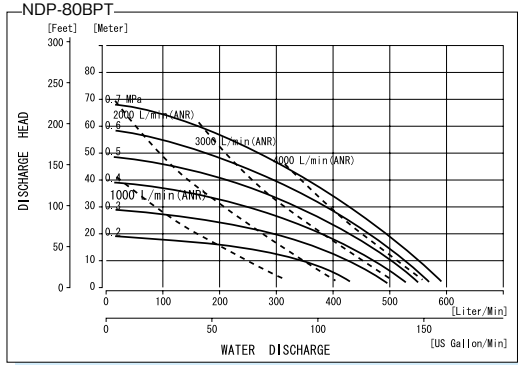



# NDP-32 Series

190L/min Maximum Flow Rate  
1-1/2" Intake, 1-1/4" Discharge

## Metal Body Pumps



NDP-32BA □

## Specifications

Port Size		IN 1-1/2"(40A), OUT 1-1/4"(32A)
Liquid	Intake	Rc1-1/2 or NPT1-1/2
	Discharge	
Air	Supply	Rc3/8 or NPT3/8 includes ball valve
	Exhaust	Rc3/4 or NPT3/4 w/ silencer
Air Supply Pressure		0.2-0.7MPa
Maximum Discharge Pressure		0.7MPa
Discharge Volume Per Cycle		Rubber diaphragm: 670mL PTFE diaphragm: 560mL
Maximum Size Solid		3mm
Net Weight		12.0kg
Body Material		Aluminum
Diaphragm Material		Buna N, PTFE

## Dimensions and Performance Curve

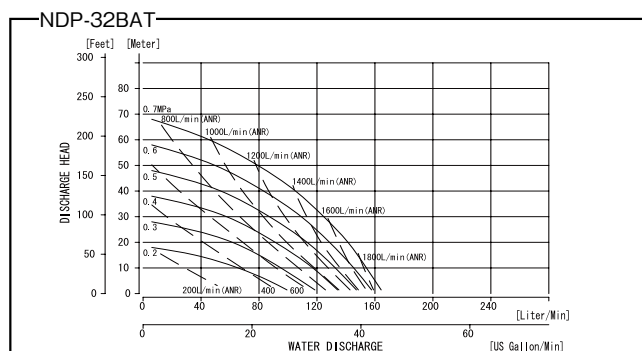
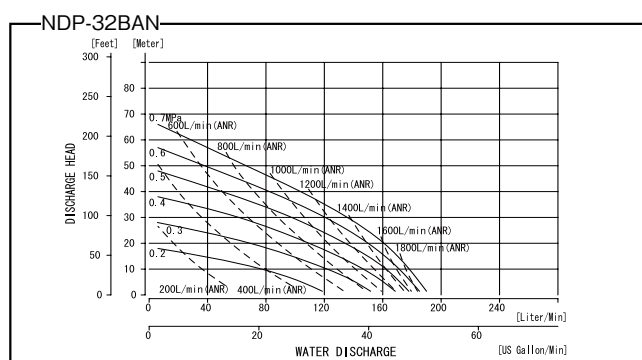
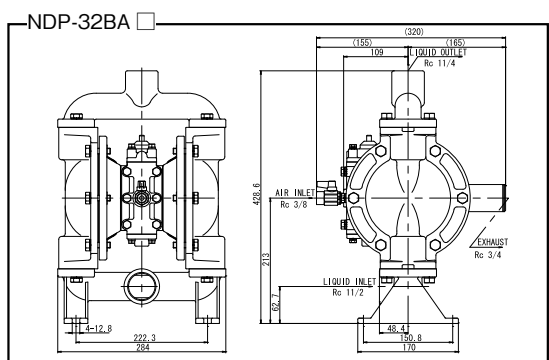

# Specialty Pumps

## Flap Valve Diaphragm Pump NDP-50FAN

The Flap Valve Diaphragm Pump NDP-50FAN is designed to pump fluids containing solids up to 30mm in diameter.

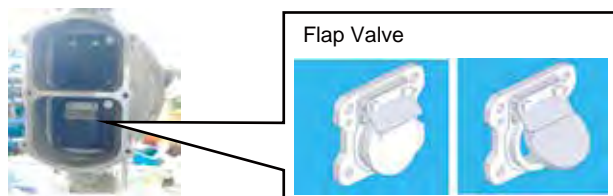

### Example Applications

- ✓ Muddy water containing soil and sand.
- ✓ Solid food waste.

### Performance Curve

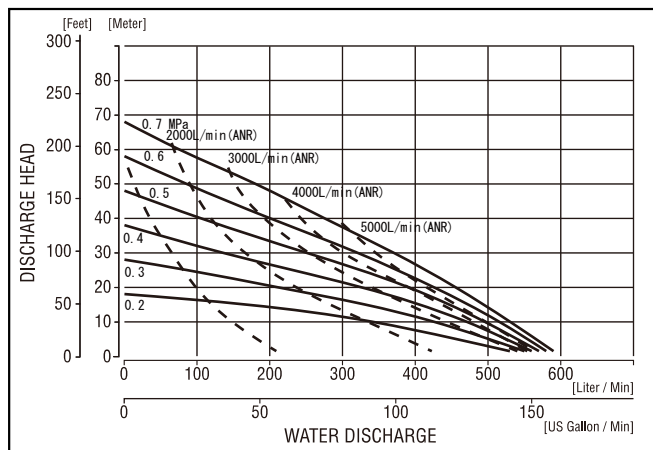

## F-Series High Purity Pumps

Extensively field proven, Yamada F-Series clean room manufactured pumps are specifically designed for the safe and efficient transfer of ultra high-purity process chemistries. They provide maximum corrosion resistance, ultra high-purity levels and low particle generation.

Pumps includes 100% machined virgin PTFE diaphragms, liquid chambers and manifolds.

Clean Room Manufactured  
1/4 inch to 1 inch Port Size



✓ For additional information, please request the High Purity Pumps catalog or visit [www.yamadacorp.co.jp/global](http://www.yamadacorp.co.jp/global)

## H-Series (Mechanical Switching Type)

Mechanical Switch Pump is designed for use in process type applications, including filter press, high pressure, extended deadheading, long runs of discharge pipe, and where air consumption is critical.



Mechanically-actuated air motor based on the diaphragm movement.

### Features

- ✓ *Stable stroke even at a very low speed operation!!*
- ✓ *The highest discharge pressure ever (maximum 0.85MPa)!!*
- ✓ *Expansion of operating pressure range*
- ✓ *Energy saving due to the reduced loss of the drive air!!*

### Available sizes

40, 50/500, and 80

### Available materials

Casing: Aluminum, Stainless Steel, Cast Iron, and PPG  
Diaphragms: CR, NBR, EPDM, FKM, PTFE, TPEE, and TPO

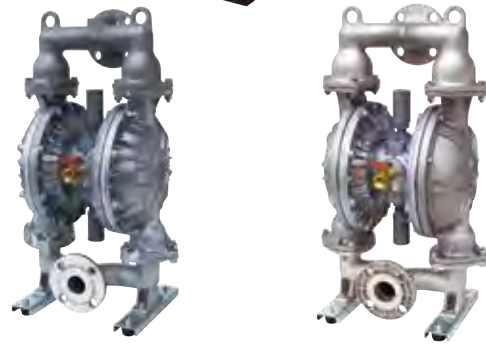

## E-Series (Electric-Switching Type)

Electric-Switching pumps are built-in high-frequency transmission proximity sensor in the pump.

### Available sizes

20, 25, 40, 50/500, and 80

### Available materials

Casing: Aluminum, Stainless Steel, Cast Iron\* and PPG  
\*Cast iron is available only for 40, 50, and 80.  
Diaphragms: CR, NBR, EPDM, FKM, PTFE, TPEE, and TPO



### Remarks

- ✓ *This series is NOT explosion-proof.*
- ✓ *A solenoid valve and PLC, which are required to operate the pump, can be supplied as an option.*

A proximity sensor is installed in the pump, and the pump operation is controlled by a solenoid valve.

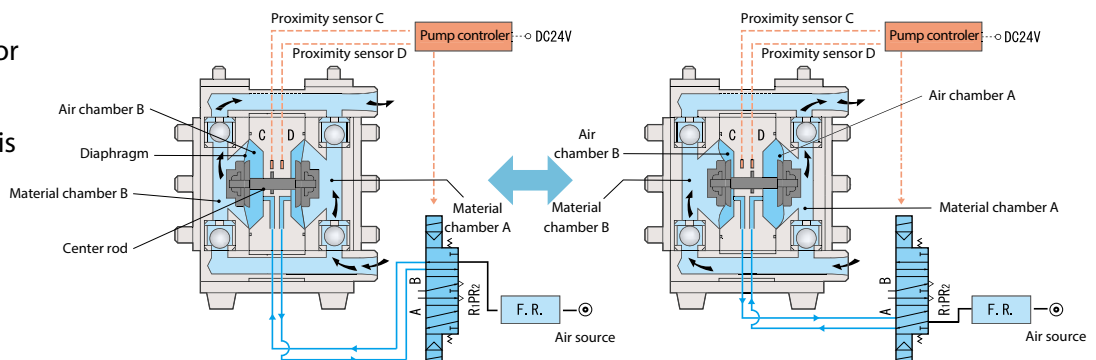

## Drum Pumps

Fit to 200L Drum  
3/8 inch and 3/4 inch Port Size



### Specifications

Model		DP-10	NDP-20
Port Size		3/8" (10A)	3/4" (20A)
Liquid	Intake	Ø17.3 O.D.	Ø34.0 O.D.
	Discharge	Rc3/8	Rc3/4
Air	Supply	Rc1/4 incl. ball valve	Rc1/4 incl. ball valve
	Exhaust	Rc3/8 incl. silencer	Rc3/4 incl. silencer
Air Supply Pressure		0.2-0.7MPa	0.2-0.7MPa
Maximum Discharge Pressure		0.7MPa	0.7MPa
Discharge Volume Per Cycle		50mL	BA□:350mL BAT:240mL
Maximum Size Solid		1mm	2mm
Net Weight		BA□:4.5kg BS□:6.2kg	10.7kg
Accessories		713237 Suction Pipe (SUS304) 803665 Bung Adapter (ADC12)	709406 Suction Pipe (SGP) 803667 Bung Adapter (SS400)

✓ Please refer to DP-10 and NDP-20 Series technical information for additional performance data.

### Dimensions

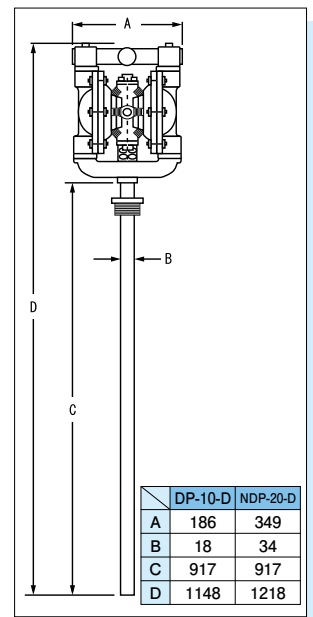

### Model Chart

	Body Material	Diaphragm Material			
		Neoprene (CR)	Buna N (NBR)	PTFE	Hytre <sup>®</sup> (TPEE)
DP-10	Aluminum (ADC12)	DP-10BAC-D (852918)	DP-10BAN-D (852919)	DP-10BAT-D (852920)	DP-10BAH-D (852934)
	Stainless Steel (SCS14/SUS316)	DP-10BSC-D (852921)	DP-10BSN-D (852922)	DP-10BST-D (852923)	DP-10BSH-D (852935)
NDP-20	Aluminum (ADC12)	NDP-20BAC-D (851397)	NDP-20BAN-D (851396)	NDP-20BAT-D (851398)	NDP-20BAH-D (852827)

## Powder Pumps

For dry powder transfer  
1 inch to 3 inch Port Size



Yamada Powder Pumps are designed to move bulk powders more effectively throughout your process vs. other unsafe and labor intensive means. These heavy duty pumps will consistently transfer fine-grained, low-bulk density dry powders in a dust-free operation.

✓ For additional information, please request the Powder Pumps catalog or visit [www.yamadacorp.co.jp/global](http://www.yamadacorp.co.jp/global)

# Accessories

## Filter/Regulators

Model No.	Model	Fits Pump
1500DP	AC20B-02G-B	NDP-5, DP-10, NDP-15
1500DP	AC25B-02G-B	NDP-20/P20
1500DP	AC30B-03G-B	NDP-25/P25, 32
1500DP	AC40B-04G-B	NDP-40/H40
1500DP	AC50B-06G-B	NDP-50/500/H50/H500/P50 NDP-80/H80



## Companion Flange

JIS, DIN, ANSI and Ferrule Flanges made of SUS304 or SUS316 or PP



## Pneumatic Cycle Counter

Pneumatic 8-digit mechanical type counter

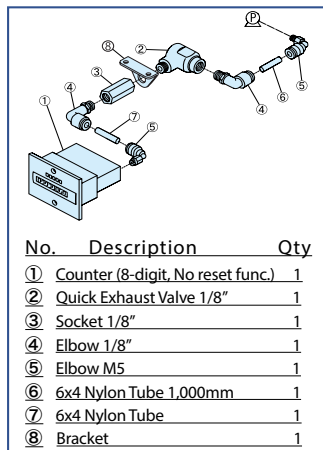

- ✓ Pump Mounting Bracket is available upon request
- ✓ No count up in dry run
- ✓ No reset function
- ✓ Modification on the center body is required for installation

Model No.	Model	Fits Pump
803413	NMC-ANS	DP-10, NDP-15 ~ 80
804847	NMC-ANH	NDP-H Series

\*Except NDP-P20,P25

No.	Description	Qty
①	Counter (8-digit, No reset func.)	1
②	Quick Exhaust Valve 1/8"	1
③	Socket 1/8"	1
④	Elbow 1/8"	1
⑤	Elbow M5	1
⑥	6x4 Nylon Tube 1,000mm	1
⑦	6x4 Nylon Tube	1
⑧	Bracket	1

## Raised Pump Bracket

Raised Pump Bracket is available on request

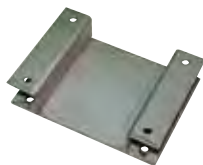

## Dry-Run Detector

The Yamada ESV-06/DRD-100 detects increases in air volume due to loss of prime or dry-running, and automatically shuts down the pump to prevent excess cycling and increased diaphragm wear.



Model No.	Model	Supply Air Press	Usable Gas	Air Inlet	Air Outlet
854006	ESV-06	0.2-0.99MPa	Air / Nitrogen	Rc3/4	Rc3/4
854008	DRD-100			NPT3/4	NPT3/4

# Diaphragm Leak Detector

For NDP-40, 50/500 and 80 series, install the street elbow between muffler and exhaust port.

PT thread: 634050, NPT thread: 685716 (Sold separately)

For the DP-F series, install the Sensor Mounting Kit between the sensor and the body.

the Sensor Mounting Kit: 804042 (Sold separately)



Model No.	Model	Fits Pump	Power Supply
805139	DMS-24TN	Except NDP-5 to15	DC24V

Model No.	Model Description
685968	24V AC Adapter
685969	Extension sensor cord 5M
685016	Gasket
771622	Union

# High-Low Level Controller

This unit is used to control the high and low levels of liquid being pumped into or out of a container.

This device is driven by compressed air and is therefore suitable for use in highly explosive environments.

The system is also designed to work in many harsh environments, e.g. areas with high temperature, high humidity or even areas where there are high electromagnetic fields.

It can handle any liquid with a viscosity of less than 1000cps.



1. Liquid is pumped to raise the level in the tank.

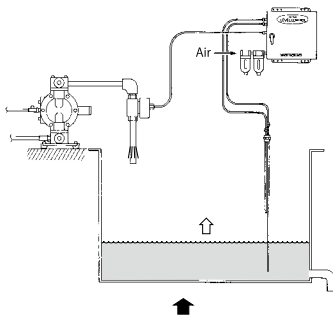

2. When the liquid reaches the upper preset limit the controller stops the supply of air to the pump to shut off the flow of liquid.

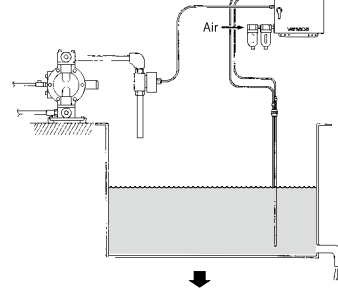

2. When the liquid level reaches the lower preset level the air supply will be started to resume the flow of liquid from the pump.

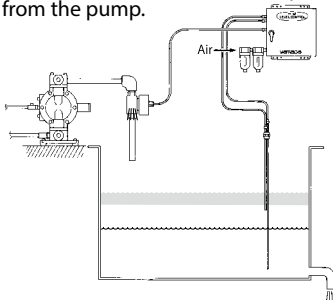

3. The liquid level becomes lower.

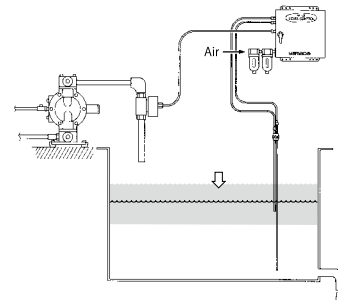

Model No.	Model	Supply Air Press.	Output Air Flow	Viscosity Limit	Weight
480005	SA-4150	0.3-0.7MPa	Max 300L/min	1Pa·s or less	6kg

## Anti-Stall Device

Retrofit-able kit that pneumatically activates the air valve instantly starting pump operation

*\*Please use with dedicated sleeve*

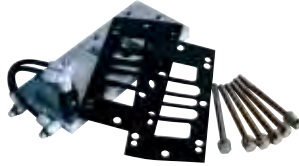

Model No.	Model	Fits Pump
804066	SVT-225	NDP-20,25,32
804065	SVT-458	NDP-40,50/500,80

### Dedicated Sleeve

Model No.	Model
804739	Sleeve for SVT225
804740	Sleeve for SVT458



## Suction Tube Kit for Drum

This Suction Tube kit fits to the 200L drum. Pump is recommended to be mounted at the height of 1M from floor level.

Material	Model No.	Model	Fits Pump	Hose	Connection	Accessories	Remark
Carbon steel	850126	SCK-200D	Size 20	Oil hose 3/4"x2M	R3/4" with Rc1-1/2 socket	Drum bung adapter (ADC12)	Please prepare suitable connector separately.
	851004	SCK-200D-HV	Size 25,40	Oil hose 1"x2M	R1" with Rc1-1/2 socket	Drum bung adapter (ADC12)	
SUS 304	803407	STU-20-20	Size 20	Not included	Rc3/4	Drum bung adapter (SUS304)	Please prepare suitable hose and connector separately.
	803405	STU-25-25	Size 25		Rc1		
	803406	STU-40-40	Size 40		Rc1-1/2		

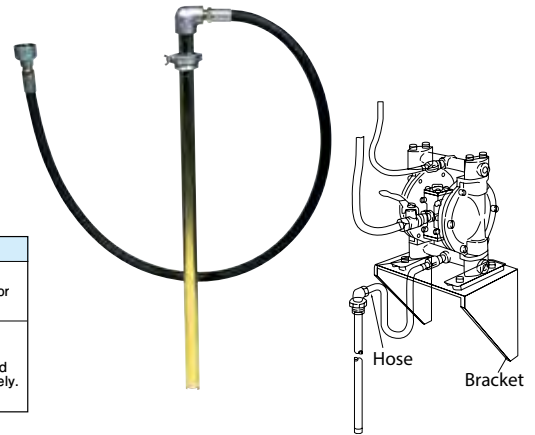

## Repair Parts Kit

Yamada offers complete repair parts kits for NDP Series pumps.

- Air Side Kit and Liquid side Kit are available.
- Repair parts kit contains exactly what you need.
- You can save your time finding the necessary individual parts and avoid order errors.



Air Side Kit



Liquid Side Kit



Packaged Repair Parts Kit

# Pulsation Dampeners

3/8", 1", 1-1/2" and 2" Port Size

Yamada AD Pulsation Dampeners incorporate a flow-through design which keeps solids in suspension, maintaining dampener effectiveness.



## Installation Diagram

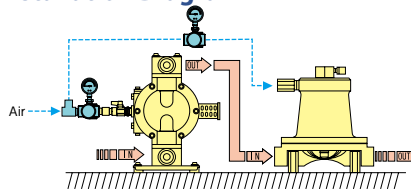

1. Dampener should be installed within 1M of the pump
2. Adjustment of supply air pressure increases the effectiveness
3. Dampener will consume air depending on condition of the pulse
4. Pre-adjustments are required prior to operation
5. Dampener will work best with at least 0.1MPa of backpressure

## AD-10 Series (fit to NDP-5, DP-10 and NDP-15)

### Specifications

Port Size		3/8" (10A)
Liquid	Intake	Rc3/8 or NPT3/8
	Discharge	Rc3/8 or NPT3/8
Air	Supply	Rc1/4 or NPT1/4
	Exhaust	Rc1/8 w/ silencer
Air Supply Pressure		0.2 - 0.7MPa
Maximum Discharge Pressure		0.7MPa
Net Weight		AD-10A □ : 2.1kg AD-10S □ : 3.0kg AD-10P □ : 2.1kg

⚠ Air supply pressure of Plastic Body Pumps is depending on the liquid temperature. Be sure to check the Liquid temperature - Pressure Correlation Chart.

### Model Chart

Body Material	Connection Liquid/Air	Diaphragm Material				
		Neoprene (CR)	Buna N (NBR)	PTFE	Hytral® (TPEE)	Santoprene® (TPO)
Aluminum (ADC12)	Rc/Rc	AD-10AC (851792)	AD-10AN (851791)	AD-10AT (851796)	AD-10AH (851782)	AD-10AS (853316)
	NPT/NPT	AD-10AC (853313)	AD-10AN (853314)	AD-10AT (853320)	AD-10AH (853321)	AD-10AS (853317)
Stainless Steel (SCS14/SUS316)	Rc/Rc	AD-10SC (851795)	AD-10SN (851794)	AD-10ST (851757)	AD-10SH (851763)	AD-10SS (853322)
	NPT/NPT	AD-10SC (853318)	AD-10SN (853319)	AD-10ST (853325)	AD-10SH (853326)	AD-10SS (853327)
Polypropylene (PPG)	Rc/Rc	AD-10PC (854045)	AD-10PN (853324)	AD-10PT (854046)	AD-10PH (853326)	AD-10PS (854047)
	NPT/NPT	AD-10PC (853323)	AD-10PN (853324)	AD-10PT (853325)	AD-10PH (853326)	AD-10PS (853327)

## AD-25 Series (fit to NDP-20/P20, NDP-25/P25 and NDP-32)

### Specifications

Port Size		1" (25A)
Liquid	Intake	Rc1 or NPT1
	Discharge	Rc1 or NPT1
Air	Supply	Rc1/4 or NPT1/4
	Exhaust	Rc1/8 w/ silencer
Air Supply Pressure		0.2 - 0.7MPa
Maximum Discharge Pressure		0.7MPa
Net Weight		AD-25A □ : 5.8kg AD-25S □ : 8.2kg AD-25F □ : 8.2kg AD-25P □ : 5.5kg AD-25V □ : 6.3kg

⚠ Air supply pressure of Plastic Body Pumps is depending on the liquid temperature. Be sure to check the Liquid temperature - Pressure Correlation Chart.

### Model Chart

Body Material	Connection Liquid/Air	Diaphragm Material						
		Neoprene (CR)	Buna N (NBR)	EPDM	Viton® (FKM)	PTFE	Hytral® (TPEE)	Santoprene® (TPO)
Aluminum (ADC12)	Rc/Rc	AD-25AC (851778)	AD-25AN (851797)	AD-25AE (851798)	AD-25AV (851799)	AD-25AT (851758)	AD-25AH (851760)	AD-25AS (853334)
	NPT/NPT	AD-25AC (853328)	AD-25AN (853329)	AD-25AE (853330)	AD-25AV (853331)	AD-25AT (853332)	AD-25AH (853333)	AD-25AS (853334)
Stainless Steel (SCS14/SUS316)	Rc/Rc	AD-25SC (851786)	AD-25SN (851802)	AD-25SE (851804)	AD-25SV (851805)	AD-25ST (851759)	AD-25SH (851761)	AD-25SS (853341)
	NPT/NPT	AD-25SC (853335)	AD-25SN (853336)	AD-25SE (853337)	AD-25SV (853338)	AD-25ST (853339)	AD-25SH (853340)	AD-25SS (853341)
Cast Iron (S45C)	Rc/Rc	AD-25FC (851800)	AD-25FN (851801)	AD-25FE (851802)	AD-25FV (851803)	AD-25FT (851765)	AD-25FH (851764)	AD-25FS (853355)
	NPT/NPT	AD-25FC (853349)	AD-25FN (853350)	AD-25FE (853351)	AD-25FV (853352)	AD-25FT (853353)	AD-25FH (853354)	AD-25FS (853355)
Polypropylene (PPG)	Rc/Rc	AD-25PC (851971)	AD-25PN (853342)	AD-25PE (853343)	AD-25PV (853344)	AD-25PT (851972)	AD-25PH (851970)	AD-25PS (853348)
	NPT/NPT	AD-25PC (853342)	AD-25PN (853343)	AD-25PE (853344)	AD-25PV (853345)	AD-25PT (853346)	AD-25PH (853347)	AD-25PS (853348)
Kynar® (PVDF)	Rc/Rc	-----	-----	AD-25VE* (854972)	AD-25VV* (854973)	AD-25VT* (854975)	AD-25VH* (854976)	AD-25VS* (854977)
	NPT/NPT	-----	-----	AD-25VE* (854973)	AD-25VV* (854974)	AD-25VT* (854975)	AD-25VH* (854976)	AD-25VS* (854977)

⚠ \* Purchaser shall not directly or indirectly, export, re-export transship or otherwise transfer this product in violation of any applicable export control laws and regulations promulgated and administered by the governments of the countries asserting jurisdiction over the parties or transaction.

## AD-40 Series (fit to NDP-40/H40)

### Specifications

Port Size		1-1/2" (40A)
Liquid	Intake	Rc1-1/2 or NPT1-1/2
	Discharge	Rc1-1/2 or NPT1-1/2
Air	Supply	Rc1/4 or NPT1/4
	Exhaust	Rc1/8 w/ silencer
Air Supply Pressure		0.2 - 0.7MPa
Maximum Discharge Pressure		0.7MPa
Net Weight		AD-40A □ : 10.4kg AD-40S □ : 15.9kg AD-40F □ : 15.2kg AD-40P □ : 11.2kg

⚠ Air supply pressure of Plastic Body Pumps is depending on the liquid temperature. Be sure to check the Liquid temperature - Pressure Correlation Chart.

### Model Chart

Body Material	Connection Liquid/Air	Diaphragm Material						
		Neoprene (CR)	Buna N (NBR)	EPDM	Viton® (FKM)	PTFE	Hytral® (TPEE)	Santoprene® (TPO)
Aluminum (ADC12)	Rc/Rc	AD-40AC (852966)	AD-40AN (852967)	AD-40AE (852968)	AD-40AV (852969)	AD-40AT (852970)	AD-40AH (852971)	AD-40AS (852972)
	NPT/NPT	AD-40AC (853361)	AD-40AN (853362)	AD-40AE (853363)	AD-40AV (853364)	AD-40AT (853365)	AD-40AH (853366)	AD-40AS (853367)
Stainless Steel (SCS14/SUS316)	Rc/Rc	AD-40SC (853001)	AD-40SN (852974)	AD-40SE (852975)	AD-40SV (852976)	AD-40ST (852977)	AD-40SH (852978)	AD-40SS (852979)
	NPT/NPT	AD-40SC (853368)	AD-40SN (853369)	AD-40SE (853370)	AD-40SV (853371)	AD-40ST (853372)	AD-40SH (853373)	AD-40SS (853374)
Cast Iron (S45C)	Rc/Rc	AD-40FC (852987)	AD-40FN (852988)	AD-40FE (852989)	AD-40FV (852990)	AD-40FT (852991)	AD-40FH (852992)	AD-40FS (852993)
	NPT/NPT	AD-40FC (853382)	AD-40FN (853383)	AD-40FE (853384)	AD-40FV (853385)	AD-40FT (853386)	AD-40FH (853387)	AD-40FS (853388)
Polypropylene (PPG)	Rc/Rc	AD-40PC (852980)	AD-40PN (852981)	AD-40PE (852982)	AD-40PV (852983)	AD-40PT (852984)	AD-40PH (852985)	AD-40PS (852986)
	NPT/NPT	AD-40PC (853375)	AD-40PN (853376)	AD-40PE (853377)	AD-40PV (853378)	AD-40PT (853379)	AD-40PH (853380)	AD-40PS (853381)
Kynar® (PVDF)	Rc/Rc	-----	-----	-----	-----	AD-40VT* (1500AD)	-----	-----
	NPT/NPT	-----	-----	-----	-----	AD-40VT* (1500AD)	-----	-----

⚠ \* Purchaser shall not directly or indirectly, export, re-export transship or otherwise transfer this product in violation of any applicable export control laws and regulations promulgated and administered by the governments of the countries asserting jurisdiction over the parties or transaction.

## AD-50 Series (fit to NDP-50/H50 and NDP-500/H500)

### Specifications

Port Size		2" (50A)
Liquid	Intake	Rc2 or NPT2
	Discharge	Rc2 or NPT2
Air	Supply	Rc1/4 or NPT1/4
	Exhaust	Rc1/8 w/ silencer
Air Supply Pressure		0.2 - 0.7MPa
Maximum Discharge Pressure		0.7MPa
Net Weight		AD-50A □ : 16.6kg AD-50S □ : 25.0kg AD-50F □ : 24.0kg AD-50P □ : 16.2kg AD-50V □ : 19.4kg

⚠ Air supply pressure of Plastic Body Pumps is depending on the liquid temperature. Be sure to check the Liquid temperature - Pressure Correlation Chart.

### Model Chart

Body Material	Connection Liquid/Air	Diaphragm Material						
		Neoprene (CR)	Buna N (NBR)	EPDM	Viton® (FKM)	PTFE	Hytral® (TPEE)	Santoprene® (TPO)
Aluminum (ADC12)	Rc/Rc	AD-50AC (852994)	AD-50AN (852995)	AD-50AE (852996)	AD-50AV (852997)	AD-50AT (852998)	AD-50AH (852999)	AD-50AS (853000)
	NPT/NPT	AD-50AC (853389)	AD-50AN (853390)	AD-50AE (853391)	AD-50AV (853392)	AD-50AT (853393)	AD-50AH (853394)	AD-50AS (853395)
Stainless Steel (SCS14/SUS316)	Rc/Rc	AD-50SC (853002)	AD-50SN (853003)	AD-50SE (853004)	AD-50SV (853005)	AD-50ST (853006)	AD-50SH (853007)	AD-50SS (853008)
	NPT/NPT	AD-50SC (853396)	AD-50SN (853397)	AD-50SE (853398)	AD-50SV (853399)	AD-50ST (853400)	AD-50SH (853401)	AD-50SS (853402)
Cast Iron (S45C)	Rc/Rc	AD-50FC (853014)	AD-50FN (853015)	AD-50FE (853016)	AD-50FV (853017)	AD-50FT (853018)	AD-50FH (853019)	AD-50FS (853020)
	NPT/NPT	AD-50FC (853410)	AD-50FN (853411)	AD-50FE (853412)	AD-50FV (853413)	AD-50FT (853414)	AD-50FH (853415)	AD-50FS (853416)
Polypropylene (PPG)	Rc/Rc	AD-50PC (853008)	AD-50PN (853009)	AD-50PE (853010)	AD-50PV (853011)	AD-50PT (853012)	AD-50PH (853013)	AD-50PS (853014)
	NPT/NPT	AD-50PC (853403)	AD-50PN (853404)	AD-50PE (853405)	AD-50PV (853406)	AD-50PT (853407)	AD-50PH (853408)	AD-50PS (853409)
Kynar® (PVDF)	Rc/Rc	-----	-----	AD-50VE* (853417)	AD-50VV* (853418)	AD-50VT* (1500AD)	AD-50VH* (853419)	AD-50VS* (853420)
	NPT/NPT	-----	-----	AD-50VE* (853418)	AD-50VV* (853419)	AD-50VT* (1500AD)	AD-50VH* (853420)	AD-50VS* (853421)

⚠ \* Purchaser shall not directly or indirectly, export, re-export transship or otherwise transfer this product in violation of any applicable export control laws and regulations promulgated and administered by the governments of the countries asserting jurisdiction over the parties or transaction.



## Without Pulsation Dampeners

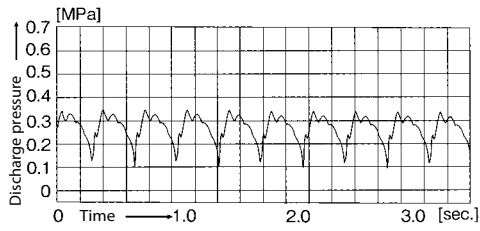

## With Pulsation Dampeners

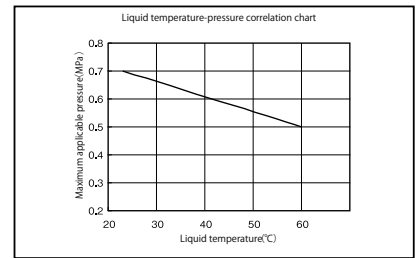
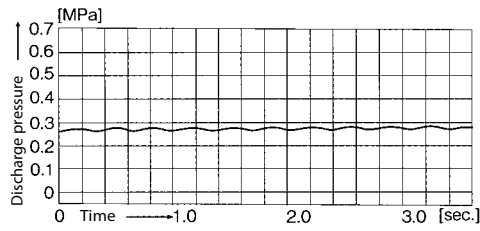

## Dimensions

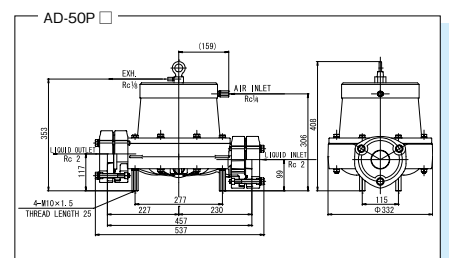
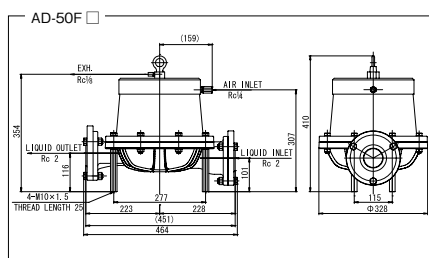
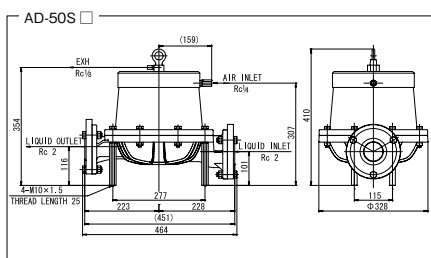
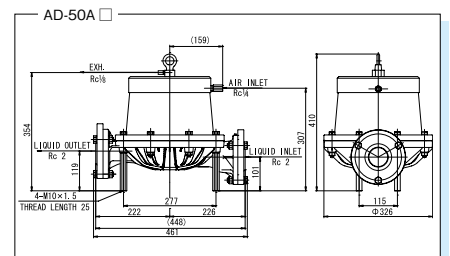
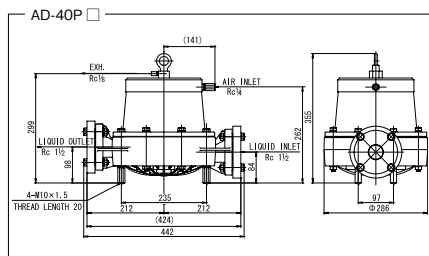
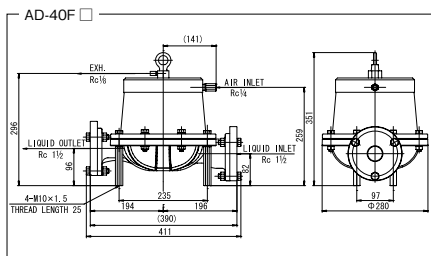
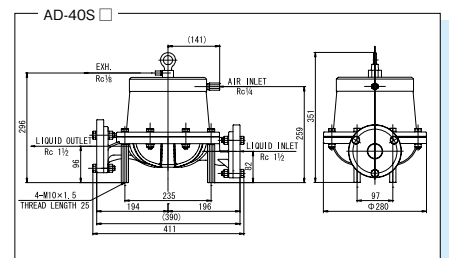
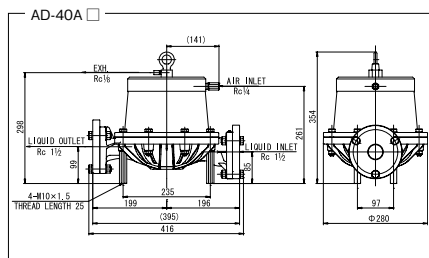
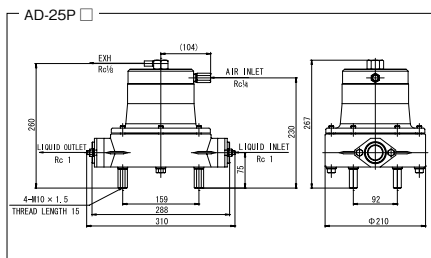
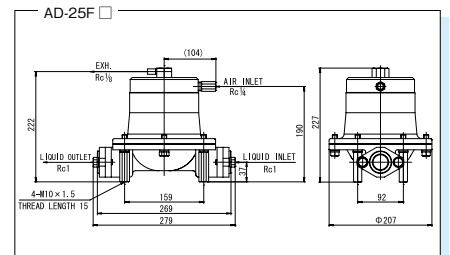
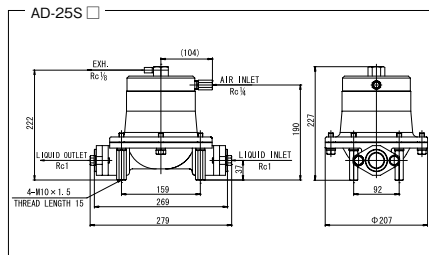
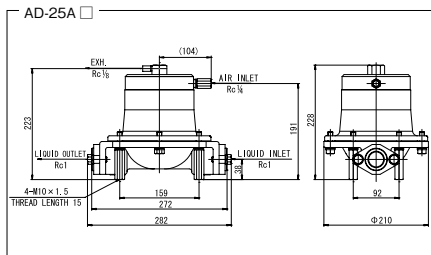
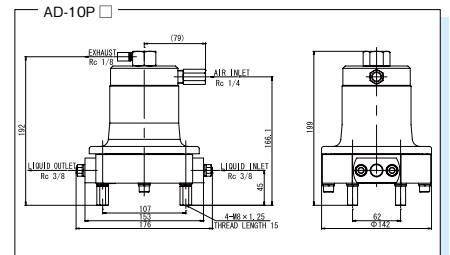
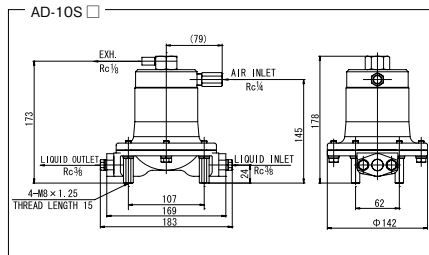
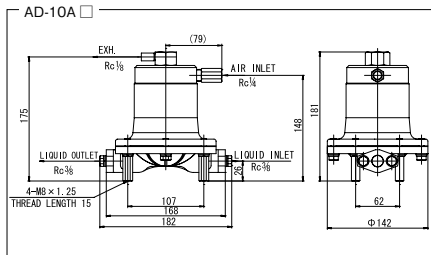

# Corrosion Resistant Chart / Installation Diagram

Diaphragm Material	C: Neoprene (CR)	N: Buna N (NBR)	E: Nordel™ (EPDM)	V: Viton® (FKM)	T: Teflon® (PTFE)	H: Hytrel® (TPEE)	S: Santoprene® (TPO)
<b>A: Aluminum</b> (ADC12 AC4C-T6)	Glaze Bilge waste water	Lubricant Kerosene Wax Cutting oil	Acetone solution	Ethylene alcohol Xylene Jet fuel	Latex Paint Ink	Lubricant, heavy oil, brake oil, naphtha, kerosene, mold lubricant	Acetone Bilge waste water
<b>S: Stainless steel</b> (SCS14 SUS316)	Ammonia water Slack lime	L.P.G Ethyl chloride Sodium peroxide	Coal slurry CMP	Methylene chloride Lactic acid Trichloroethylene	Sulfuric acid (98%) Nitric acid (less than 25%) MEK Acetone		
<b>F: Cast iron</b> (FC250 S45C)	Kaolin liquid Ferrite slurry Active sludge Sewage water						
<b>P: Polypropylene</b> (PPG)	Ferrous chloride Glaze	Whiskey Sodium silicate Methyl alcohol	Sulfuric acid (less than 20%)	Ethyl alcohol Perchloroethylene	Plating solution Photograph developing liquid Benzene Hydrogen peroxide		
<b>V: Kynar®</b> (PVDF)					Sodium hypochlorite		
<b>D: Groundable Acetal</b> (POM)	Methyl alcohol Sodium sulfate Ammonium sulfate	Ethyl alcohol Methyl alcohol Ammonium nitrate	Acetaldehyde Butylnitryl Chromic acid	Copper sulfate (II) Sodium sulfate Barium sulfate	Ammonium nitrate Barium sulfate Dimethyl ether	Ethyl alcohol Ammonium chloride Calcium chloride	Acetone Ammonia water Butyl acetate

✓ This table is for reference only, and the accuracy of the information it contains is not guaranteed. Pump model selection should be carried out by the end user based on operating conditions such as liquid concentration, temperature, and other factors, as well as information issued by the chemical manufacturer.

## Ideal Installation for Air-Operated Double Diaphragm Pump

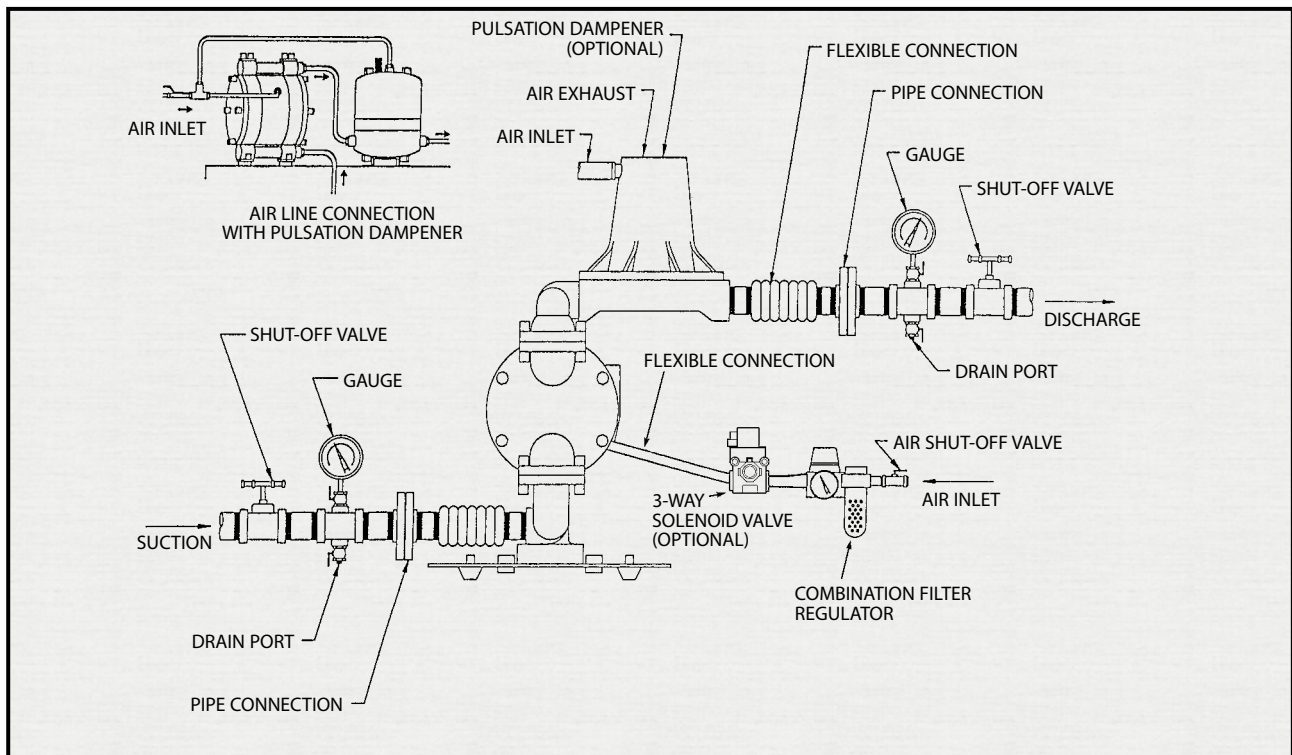

# Markets



## General Industry and Wastewater Treatment

<b>APPLICATIONS</b>	For circulation and spraying of mold-release agents, factory wastewater, and pumping of waste oil.
<b>TRANSFER FLUID</b>	Mold-release agent, hydraulic oil/cutting oil, coolant liquid, waste oil, Sewage
<b>INTRODUCTION REASONS</b>	Circulation and spraying of mold-release agent can be stopped at the end. Can be used even if sludge or sludge is mixed in the liquid.



## Chemical Industry

<b>APPLICATIONS</b>	Transfer of flammable liquids in explosion-proof area
<b>TRANSFER FLUID</b>	Chemicals, additives, solvents
<b>INTRODUCTION REASONS</b>	Air-powered. Safe and secure for use in factories where explosion-proof protection is required. Can be easily transported by trolley, etc., and highly versatile.



## Painting and Printing

<b>APPLICATIONS</b>	As a coating pump for supplying paint to roll coaters, coating exterior wall materials, etc.
<b>TRANSFER FLUID</b>	Paints, varnishes, lacquers, titanium dioxide, latex, low viscosity inks such as flexographic and gravure, solvents
<b>INTRODUCTION REASONS</b>	Easy to adjust discharge volume, highly portable, easy disassembly and cleaning, allowing easy change of paint colors. Cutting off the flow at the end point achieves simplification of equipment.



## Energy Industry

<b>APPLICATIONS</b>	Drainage from power plants, waste liquid collection during piping and tank cleaning, fuel transfer in explosion-proof area
<b>TRANSFER FLUID</b>	Rainwater, seawater, cleaning fluids, heavy oil, naphtha, solvents
<b>INTRODUCTION REASONS</b>	Air-powered. Safe and secure for use in factories where explosion-proof protection is required. Can be easily transported by trolley, etc., and highly versatile.



## Coal Mine

<b>APPLICATIONS</b>	Transferring liquids mixed with sediment, wastewater, and oil
<b>TRANSFER FLUID</b>	Sludge, fuel oil, oil
<b>INTRODUCTION REASONS</b>	Can transfer even liquids mixed with sediment, and is used in mining and shale oil extraction. High maintainability.



## Ceramic

<b>APPLICATIONS</b>	Transfer of clay and glazes
<b>TRANSFER FLUID</b>	Slurry, glaze
<b>INTRODUCTION REASONS</b>	Slurry transfer is possible. Cutting off the flow at the end point is possible.



## Food and Beverages

<b>APPLICATIONS</b>	Transfer of food ingredients and additives, supply of pipe cleaning solution, collection of waste oil and wastewater
<b>TRANSFER FLUID</b>	Food ingredients, disinfectants, food additives, alcohol, waste liquids
<b>INTRODUCTION REASONS</b>	Easy disassembly and cleaning, with excellent operability. Air-powered type, safe even around water.

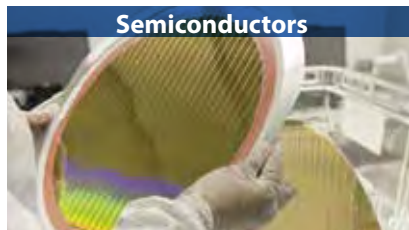

## Semiconductors

<b>APPLICATIONS</b>	As a chemical supply system pump
<b>TRANSFER FLUID</b>	Chemicals, pure water, waste liquids
<b>INTRODUCTION REASONS</b>	Fluoroplastic wetted parts with a high corrosion resistance. Non-metallic specification eliminates the risk of contamination by metal ions.



## Drug Production

<b>APPLICATIONS</b>	Transfer of alcohol, disinfectants and solvents
<b>TRANSFER FLUID</b>	Alcohol, disinfectants, solvents, formulations, water
<b>INTRODUCTION REASONS</b>	Small pump size allows for space-saving installation. Easy disassembly for cleaning.



## Automobiles

<b>APPLICATIONS</b>	Supplying oil, coolant fluid, paint, etc.
<b>TRANSFER FLUID</b>	Oil, coolant fluid, paint, etc.
<b>INTRODUCTION REASONS</b>	Empty operation is possible to drain oil and fuel.



## Shipbuilding

<b>APPLICATIONS</b>	Rainwater discharge, bilge and waste oil collection, chemical transfer, and lubricant supply
<b>TRANSFER FLUID</b>	Bilge, rainwater, waste oil, chemicals, lubricating oil
<b>INTRODUCTION REASONS</b>	Excellent self-suction capability, usable even when sludge or slurry is mixed in the liquid.



## Powder

<b>APPLICATIONS</b>	Transfer of anhydrous powder
<b>TRANSFER FLUID</b>	Diatomaceous earth, toner, powder paint, silica
<b>INTRODUCTION REASONS</b>	Simplification of equipment, space-saving. Air-powered type for easy handling.



## CAUTION WHEN SELECTING A PUMP

Yamada offers a large range of Air Operated Pumps to cater for many different kinds of materials and conditions. When selecting the most appropriate pump for a particular selection and installation please consult your local Yamada Pump Distributor or Yamada Corporation.

Your Local Distributor:

All product specifications and data are subject to change without notice.

Revised: Dec. 2024

**YAMADA CORPORATION**

**International Sales Department**

No.1-3, 1-Chome, Minami-Magome,  
Ohta-ku, Tokyo 143-8504, Japan

Phone +81-(0)3-3777-0241

Fax +81-(0)3-3777-0584

E-mail: [intl@yamadacorp.co.jp](mailto:intl@yamadacorp.co.jp)

Web: <https://ap.yamadacorp.co.jp/>